

Gruppe **A/B**
 Group

Testblatt nach Anhang J des Internationalen Automobil-Sportgesetzes
 Homologation form in accordance with appendix J of the international sporting code

Homologation gültig ab 01.03.1987
 Homologation valid as from

in Gruppe A
 in group

Foto A
 Photo A



Foto B
 Photo B



1. Definitionen
 Definitions

101. Hersteller BMW Motorsport GmbH
 Manufacturer

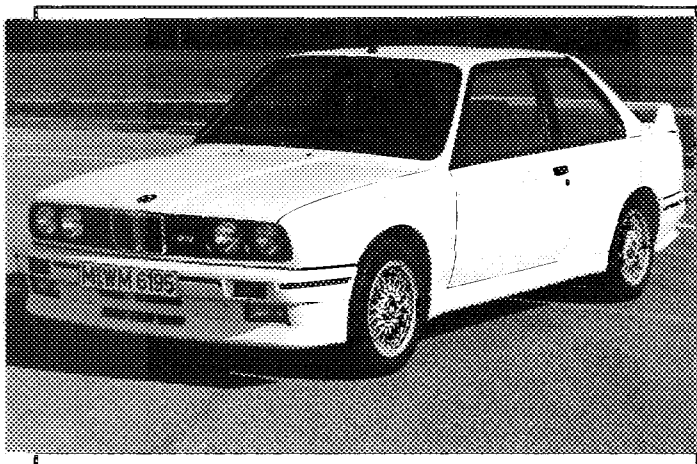
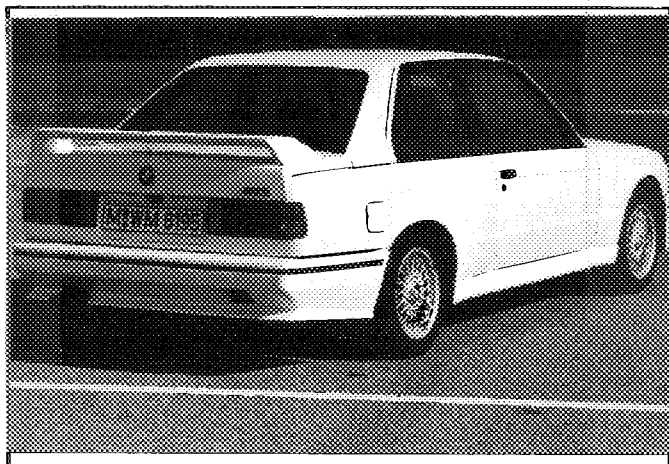
102. Handelsbezeichnung — Typ und Modell M 3
 Commercial name(s) — Type and model

103. Gesamthubraum 2302,1 ccm
 Cylinder capacity

104. Art der Konstruktion getrennt, Material des Chassis
 Type of car construction Separate, material of chassis

selbsttragend, Material der Karosserie Stahl / steel
 Unitary construction

105. Anzahl der Volumina 3
 Number of volumes

106. Anzahl der Sitzplätze 4
 Number of places

Unterschrift und Stempel
 der Nationalen Sporthoheit
 Signature and stamp
 of national sporting authority

1 *[Signature]*
 1 *[Stamp]*
 Upterschrift und Stempel
 der FISA
 Signature and stamp
 of F.I.S.A.
**FÉDÉRATION INTERNATIONALE
 DE L'AUTOMOBILE**

Marke BMW
Make

Modell M 3
Model

Homologation Nr. A-5327
Homologation Nr.

2. Abmessungen — Gewichte

Dimensions — weights

202. Länge über alles 4355 mm $\pm 1\%$
Overall length

203. Breite über alles 1680 mm $\pm 1\%$
Overall width

Meßpunkt 300 mm vor Hinterradmitte /
Where measured 300 mm before rearwheelmiddle

204. Karosseriebreite:
Width of bodywork:

a) Vorderradmitte 1662 mm $\pm 1\%$
At front axle

b) Hinterradmitte 1661 mm $\pm 1\%$
At rear axle

206. Radstand: a) Rechts 2565,5 mm $\pm 1\%$
Wheelbase: Right

b) Links 2565,5 mm $\pm 1\%$
Left

209. Überhang: a) Vorne 789,5 mm $\pm 1\%$
Overhang: Front

b) Hinten 1000 mm $\pm 1\%$
Rear

210. Entfernung „G“ (Lenkrad-hintere Trennwand) 1570 mm $\pm 1\%$
Distance „G“ (steering wheel — rear bulkhead)

3. Motor (Für Kreiskolbenmotor siehe Artikel 335 auf Nachtragsblatt)

Engine (In case of rotative engine, see Article 335 on complementary form)

301. Einbauort und Lage des Motors Über Vorderachse 30° $\pm 5^\circ$ nach rechts/front 30° $\pm 5^\circ$ right
Location and position of the engine

303. Arbeitsverfahren 4-Takt / 4-stroke
Cycle

304. Aufladung ja / nein; Typ _____
Supercharging yes/no: Type
(Bei Aufladung siehe auch Artikel 334 auf Nachtragsblatt)
(In case of supercharging see also Article 334 on complementary form)

305. Anzahl und Anordnung der Zylinder 4 Zylinder in Reihe / 4 cylinder in line
Number and layout of the cylinders

306. Kühlsystem Flüssigkeit / liquide
Cooling system

307. Hubraum: a) Pro Zylinder 575,5 ccm b) Gesamt 2302,1 ccm
Cylinder capacity: a) Unitary Total

c) Maximal zulässiger Hubraum* 2331.8 ccm
c) Maximum total allowed*

* (Diese Angabe gilt nicht für Gruppe N)
* (This indication is not to be considered in Group N)

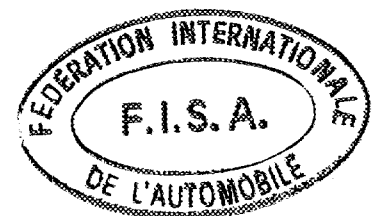

Marke BMW
Make

Modell M 3
Model

Homologation Nr. A-5327
Homologation Nr.

312. Material des Zylinderblocks Grauguß / cast iron
Cylinder block material

313. Laufbuchsen: a) ja / nein c) Typ -
Sleeves. yes/no Type

314. Bohrung 93,4 mm
Bore

315. Maximal zulässige Bohrung 94 mm
Maximum bore allowed (Diese Angabe gilt nicht für Gruppe N)
(This indication is not be considered in Group N)

316. Hub 84 mm
Stroke

318. Pleuel: a) Material Stahl / steel b) Art des Pleuelfußes geteilt / divided
Connecting rod: a) Material Big end type

c) Innerer Durchmesser des Pleuelfußes (ohne Lager) 52 mm $\pm 1\%$
Interior diameter of the big end (without bearings)

d) Länge zwischen den Achsen 144 mm ($\pm 0,1$ mm) e) Mindestgewicht 653 g
Length between the axes Minimum weight

319. Kurbelwelle: a) Herstellungsart einteilig / one piece
Crankshaft: type of manufacture

b) Material Stahl / steel
Material

c) gegossen geschmiedet d) Anzahl der Kurbelwellen-Hauptlager 5
moulded stamped Number of bearings

e) Art der Kurbelwellen-Hauptlager Gleitlager / friction bearing
Type of bearings

f) Durchmesser der Kurbelwellen-Hauptlager 55 mm $\pm 0,2\%$
Diameter of bearings

g) Material der Lagerdeckel Stahl / steel
Bearing caps material

h) Mindestgewicht der Kurbelwelle (allein) 18900 g
Minimum weight of the bare crankshaft

320. Schwungrad: a) Material Stahl / steel
Flywheel: Material

b) Mindestgewicht mit Anlaßzahnkranz 7790 g
Minimum weight of the flywheel with starter ring

321. Zylinderkopf: a) Anzahl der Zylinderköpfe 1 b) Material Aluminium
Cylinderhead: Number of cylinderheads Material

323. Kraftstoffzufuhr durch Vergaser: a) Anzahl der Vergaser -
Fuel feed by carburettor(s): Number of carburettors

b) Typ - c) Marke und Modell -
Type Marke and model

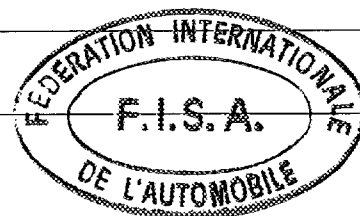

Marke BMW
Make

Modell M 3
Model

Homologation Nr. _____
Homologation Nr.

- d) Anzahl der Gemischdurchlässe je Vergaser _____
Number of mixture passages per carburettor
- e) Maximaler Durchmesser der Gemischöffnung am Vergaserausgang _____ mm
Maximum diameter of the flange hole of the carburettor exit port
- f) Durchmesser des Lufttrichters am engsten Punkt _____ mm
Diameter of the venturi at the narrowest point

324. Kraftstoffzufuhr durch Einspritzung Bosch
Fuel feed by injection: Hersteller / Manufacturer
- b) Modell des Einspritzsystems DME
Model of injection system:
- c) Art der Kraftstoffdosierung mechanisch elektronisch hydraulisch
Kind of fuel measurement: mechanical / **electronic** / hydraulic
- c1) Kolbenpumpe ja / nein c2) Luftvolumenmessung ja / nein
Piston pump / yes/no Measurement of air volume / yes/no
- c3) Luftmassenmessung ja / nein c4) Luftgeschwindigkeitsmessung ja / nein
Measurement of air mass / yes/no Measurement of air speed / yes/no
- c5) Luftdruckmessung ja / nein Weicher Druck wird zur Messung herangezogen? _____ bar
Measurement of air pressure / yes/no Which pressure is taken for measurement?
- d) Abmessungen der Drosselklappe(n) oder der/des Schieber(s) 46 -0,25 mm
Effective dimensions of measure position in the throttle area
- e) Anzahl der effektiven Kraftstoffauslässe 4
Number of effective fuel outlets
- f) Lage der Einspritzventile Saugrohr Zylinderkopf
Position of injection valves: Inlet manifold / Cylinder head
- g) Teile des Einspritzsystems, die zur Kraftstoffdosierung dienen: Steuergerät / control unit
Statement of fuel measuring parts of injection system

325. Nockenwelle: a) Anzahl 2 b) Lage Zylinderkopf / cylinder head
Camshaft Number Location
- c) Art des Antriebs Kette / chain d) Anzahl der Lager pro Nockenwelle 5
Driving system Number of bearings for each shaft
- f) Art der Ventilbetätigung Tassenstößel / bucket tappet
Type of valve operation

326. Steuerung: e) Maximaler Ventilhub 10,48 mm Einlaß 10,48 mm Auslaß 10,48 mm
Timing Maximum valve lift Inlet Exhaust
- Mit einem Spiel von 0,28 mm 0,28 mm
With clearance

327. Einlaß: a) Material des Ansaugkrümmers Aluminium
inlet: Material of the manifold
- b) Anzahl der Ansaugkrümmerelemente 2 c) Anzahl der Ventile pro Zylinder 2
Number of manifold elements Number of valves per cylinder
- d) Maximaler Durchmesser der Ventile 37 mm e) Durchmesser des Ventilschafts 6,975 -0,015 mm
Maximum diameter of the valves Diameter of the valve stem zwei Schraubenfedern /
- f) Länge des Ventils 121,2 + 0,4 - 0,1 mm g) Art der Ventilsfeder two coilsprings
Length of the valve Type of valve springs

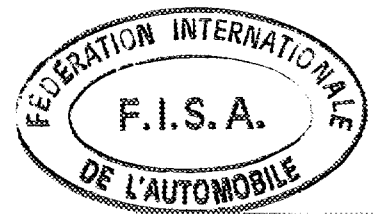

Marke BMW Modell M 3 Homologation Nr. _____
 Make Model Homologation Nr.

328. Auslaß: a) Material des Auslaßkrümmers Stahl / steel
 Exhaust. Material of the manifold

b) Anzahl der Auslaßkrümmerelemente 1 d) Anzahl der Ventile pro Zylinder 2
 Number of manifold elements Number of valves per cylinder

e) Maximaler Durchmesser der Ventile 32 mm f) Durchmesser des Ventilschafts 6,96 - 0,015 mm
 Maximum diameter of the valves Diameter of the valve stem

g) Länge des Ventils 123,8 ± 0,25 mm h) Art der Ventilsfeder zwei Schraubenfedern / two coilsprings
 Length of the valve Type of valve springs

330. Zündanlage: a) Art DME
 Ignition system. Type

b) Anzahl der Kerzen pro Zylinder 1 c) Anzahl der Verteiler 1
 Number of plugs per cylinder Number of distributors

333. Schiersystem: a) Art Naß-Sumpf / wet-sump b) Anzahl der Ölpumpen 1
 Lubrication system. Type Number of oil pumps

4. Kraftstoffanlage
 Fuel circuit

401. Tank: a) Anzahl 1 + Zusatztank / 1 + add. tank b) Lage unter der hinteren Sitzbank + Kofferraum / under rearseat, outside + luggage comp.
 Fuel tank. Number Location

c) Material Stahlblech / sheetsteel d) Maximaler Inhalt 55 + 15 L Liter
 Material Maximum capacity litre

5. Elektrische Ausrüstung
 Electrical equipment

501. Batterie(n): a) Anzahl 1
 Battery(ies). Number

6. Kraftübertragung
 Drive

601. Antriebsräder vorn hinten
 driving wheels: front rear

602. Kupplung: b) Art der Betätigung hydraulisch / hydraulic
 Clutch: Drive system

c) Anzahl der Scheiben 1
 Number of plates

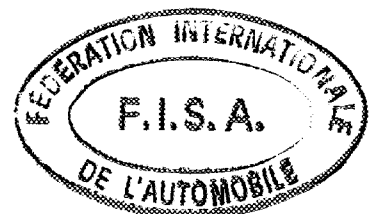

603. Getriebe: a) Lage am Motor / engine output
 Gear-box: Location:

b) Manuelles Getriebe, Marke Getrag c) Automatisches Getriebe, Marke -
 „Manual“ make „Automatic“ make

d) Anordnung des Gangschalthebels Getriebetunnel / gearbox tunnel
 Location of the gear lever:

e) Übersetzungen
 Ratios

	Handschtaltung Manual:			Automatik Automatic:			Zusätzl. Getriebe Additional: G B		
	Über- setzungen ratio	Anzahl der Zähne number of teeth	synchro.	Über- setzungen ratio	Anzahl der Zähne number of teeth	synchro.	Über- setzungen ratio	Anzahl der Zähne number of teeth	synchro.
1	3,717	36 : 16	x				2,337	36 : 16	x
2	2,403	32 : 22	x				1,681	34 : 21	x
3	1,766	31 : 29	x				1,358	34 : 26	x
4	1,263	26 : 34	x				1,150	31 : 28	x
5	1,000	./.	x				1,000	-	x
Rück- wärts R	4,234	41 : 16					2,660	41 : 16	
Kon- stante Con- stant	1,652	38 : 23					1,0384	27 : 26	

f) Schalt-Schema
 Gear change gate

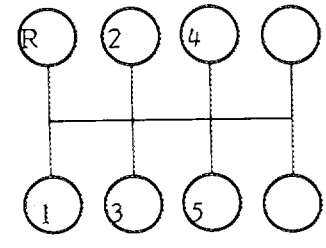
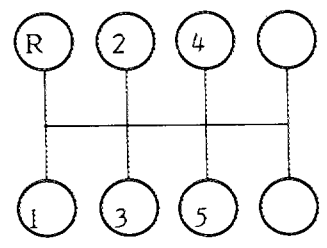

604. Schnellgang: a) Art _____
 Overdrive: Type

b) Übersetzung _____ c) Anzahl der Zähne _____
 Ratio Number of teeth

d) Vorwärtsgänge, zu denen der Schnellgang zugeschaltet werden kann _____
 Usuable with the following gears

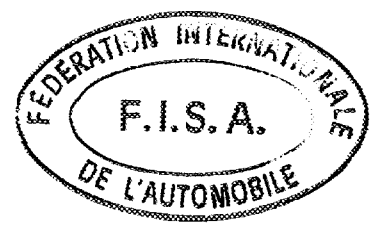

Marke BMW
Make

Modell M 3
Model

Homologation Nr. A-5327
Homologation No.

605. Antriebsachse
Final drive

Vorn Front	Hinten Rear
a) Art des Achsantriebs Type of final drive	Hypoid-Antrieb / hypoid drive
b) Übersetzungsverhältnis Ratio	3,25 : 1
c) Anzahl der Zähne Number of teeth	39 : 12
d) Art des Sperrdifferentials (wenn vorhanden) Type of differential limitation (if provided)	Lamellensperrdiff. / limited slip differential

e) Übersetzungsverhältnis des Verteilergetriebes
Ratio of the transfer box

606. Art der Gelenkwelle
Type of transmission shaft

2-teilig, mit Kreuzgelenk Mitte + Hinten
2-piece with universal joints

7. Radaufhängung Suspension:

701. Art der Radaufhängung: a) Vorn Eingelenk-Federbein / single joint strut
Type of suspension: Front

b) Hinten Schräglenker / semi trailing arm
Rear

702. Schraubenfedern: Vorn: ja / ~~nein~~ Hinten: ja / ~~nein~~
Helicoidal springs: Front: yes/no Rear: yes/no

703. Blattfedern: Vorn: ~~ja~~ / nein Hinten: ~~ja~~ / nein
Leaf springs: Front: yes/no Rear: yes/no

704. Drehstab: Vorn: ~~ja~~ / nein Hinten: ~~ja~~ / nein
Torsion bar: Front: yes/no Rear: yes/no

705. Andere Arten der Radaufhängung: s. Bild / Zeichnung auf Seite 15
Other type of suspension: See photo or drawing on page 15



Marke BMW
Make

Modell M 3
Model

Homologation Nr. A-5327
Homologation Nr.

707. Stoßdämpfer
Shock absorbers

- a) Anzahl je Rad
Number per wheel
- b) Art
Type
- c) Funktionsprinzip
Working principle

Vorn Front	Hinten Rear
1	1
Teleskop / telescopic	Teleskop / telescopic
hydraulisch / hydraulic	hydraulisch / hydraulic

8. Fahrwerk
Running gear

801. Räder:
Wheels: a) Durchmesser Vorn 15 " / 380,4 mm Hinten 15 " / 380,4 mm
Diameter Front Rear
803. Bremsen:
Brakes: a) Bremssystem hydraulisch mit ABS / hydraulic with ABS
Braking system
- b) Anzahl der Hauptzylinder 1 Tandem b1) Bohrung 23,81 / 23,81 mm
Number of master cylinders Bore
- c) Servo-Bremse ja / ~~nein~~ c1) Marke und Art ATE-Mastervac
Power assisted brakes yes/no Make and type
- d) Bremskraftregler ja / ~~nein~~ d1) Lage Motorraum vorne links/engine compartment
Braking adjuster yes/no Location

- e) Anzahl der Zylinder je Rad
Number of cylinders per wheel
- 1) Bohrung
Bore
- f) Trommelbremsen
Drum brakes
- 1) Innendurchmesser
Interior diameter
- 2) Anzahl der Bremsbacken je Rad
Number of shoes per wheel
- 3) Bremsfläche
Braking surface
- 4) Breite der Bremsbeläge
Width of the shoes
- g) Scheibenbremsen
Disc brakes
- 1) Anzahl der Bremsbeläge je Rad
Number of pads per wheel
- 2) Anzahl der Sättel je Rad
Number of callipers per wheel

Vorn Front	Hinten Rear
1	1
54 mm	38 mm
_____ mm (± 1,5 mm)	_____ mm (± 1,5 mm)
_____	_____
_____ qcm	_____ qcm
_____ mm	_____ mm
2	2
1	1

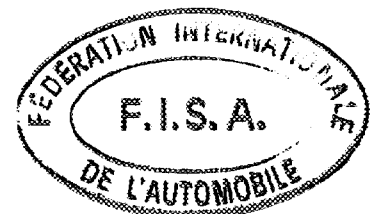

Marke BMW
Make

Modell M 3
Model:

Homologation Nr. A-5327
Homologation Nr

	Vorn Front	Hinten Rear
3) Material der Bremssättel Caliper material:	GGG 50/cast iron	GGG 50/cast iron
4) Maximaie Dicke der Scheibe Maximum disc thickness	25 ± 1,0 mm	12 ± 1,0 mm
5) Außendurchmesser der Scheibe Exterior diameter of the disc	280 mm (± 1 mm)	282 mm (± 1 mm)
6) Außendurchmesser der Belagfläche Exterior diameter of the shoes rubbing surface	280 ± 1,5 mm	282 ± 1,5 mm
7) Innendurchmesser der Belagfläche Interior diameter of the shoes rubbing surface	174 ± 1,5 mm	198 ± 1,5 mm
8) Länge der Beläge über Alies Overall length of the shoes	112 ± 1,5 mm	88,5 ± 1,5 mm
9) Belüftete Scheiben Ventilated disc	ja / nein yes/no	ja /nein yes/no
10) Bremsfläche je Rad Braking surface per wheel:	777,32 qcm	655,96 qcm

h) Feststellbremse zwischen den Vordersitzen /
Parking brake
Location of the lever

1) Betätigungssystem Seil / cable
Command system

2) Lage des Bremshebels between front seats

3) Wirkung auf die Räder Vorn Hinten
On which wheels Front Rear

804. Lenkung: a) Art: Zahnstangenlenkung / rack and pinion steering
Type

b) Übersetzungsverhältnis 19,6 : 1

c) Lenkhilfe ja / ~~nein~~
Power assisted yes/no

9. Karosserie
Bodywork

901. Innen: a) Belüftung ja / ~~nein~~
Interior: Ventilation yes/no

b) Heizung ja / ~~nein~~
Heating yes/no

f) Sonderausstattung Schiebedach ja / ~~nein~~
Sun roof optional yes/no

1) Art Schiebe-Hebedach / sliding lift roof
Type

2) Betätigungssystem Handkurbel-elektrisch / handcrank-electric
Command system

g) Öffnungssystem der Seitenscheiben: Handkurbel-elektrisch / handcrank-electric
Opening system for the side windows
Vorn Front
Hinten Rear

902. Außen: a) Anzahl der Türen 2
Exterior: Number of doors

b) Heckklappe ja / ~~nein~~
Rear tailgate yes/no

c) Material der Türen Stahlblech / sheetsteel
Door material
Vorn Front
Hinten Rear



Marke BMW
Make

Modell M 3
Model

Homologation Nr. _____
Homologation Nr.

- d) Material der Fronthaube Stahlblech / sheetsteel
Front bonnet material
- e) Material der Heckhaube/-klappe Kunststoff / plastic
Rear bonnet / tailgate material
- f) Material der Karosserie Stahlblech / sheetsteel
Bodywork material
- g) Material der Windschutzscheibe Verbundglas / laminated glass
Windscreen material
- h) Material der Heckscheibe Sicherheitsglas / safety glass
Rear window material
- i) Material der hinteren Seitenscheiben Sicherheitsglas / safety glass
Rear quarter lights material
- k) Material der Seitenscheiben Sicherheitsglas / safety glass
Side window material
 Vorn Sicherheitsglas / safety glass
front
 Hinten Sicherheitsglas / safety glass
rear
- l) Material der vorderen Stoßstange Kunststoff / plastic
Material of the front bumper
- m) Material der hinteren Stoßstange Kunststoff / plastic
Material of the rear bumper

Zusätzliche Informationen

Complementary informations

Winkel zwischen den Ventilen / angle between valves

$38^\circ \pm 10'$

$38^\circ \pm 10'$

Katalysator Version /catalytic version:

Auspuffkrümmer mit Lamdasonde /
exhaust manifold with lamdasonde

Foto 1

- Heckklappe und -Spoiler aus Kunststoff
Rear bonnet and rear spoiler (plastic)
- Schwellerverkleidung aus Kunststoff
Door sill lining (plastic)



Foto 1



Marke BMW
Make

Modell M 3
Mode:

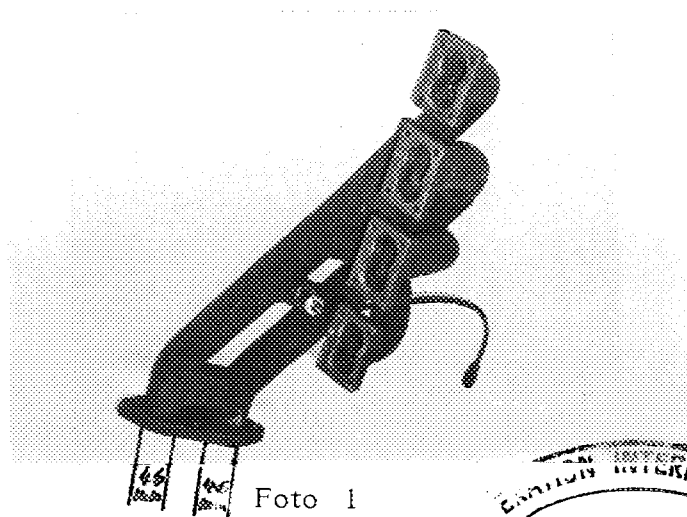
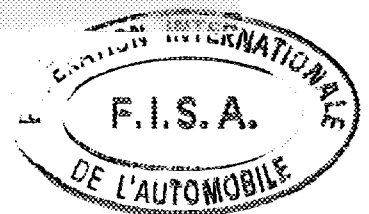
Homologation Nr. A-5327
Homologation Nr.

Fotos oder Zeichnungen der Befestigungen an der Karosserie:
Photos or drawings of the attachments on the Body:

Nachtrag Nr. _____
Ext. Nr.

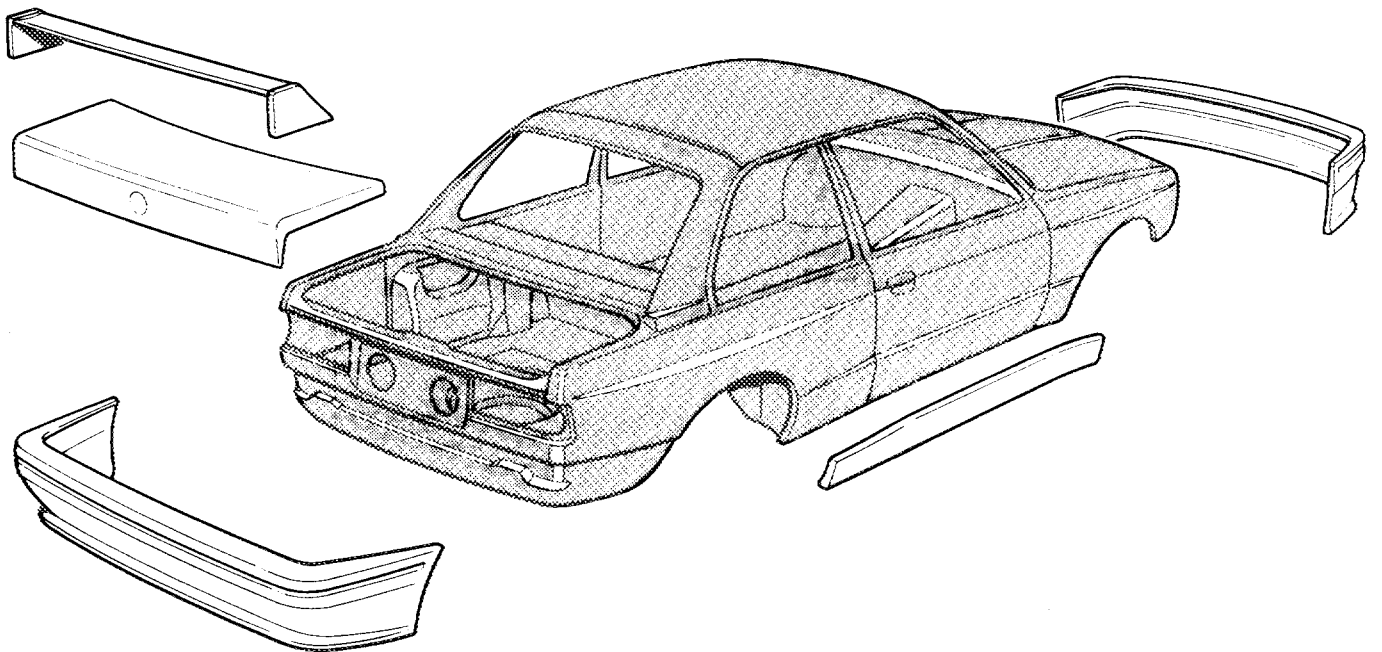

Herausgestellte Karosserieteile aus Kunststoff /
parts put out made out of plastic

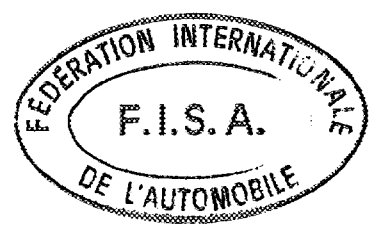

Marke BMW
Make

Modell M 3
Model

Homologation Nr. A-5327
Homologation Nr.

Fotos
Photos

Motor
Engine

C) Rechte Seitenansicht Motor (ausgebaut)
Right hand view of dismantled engine

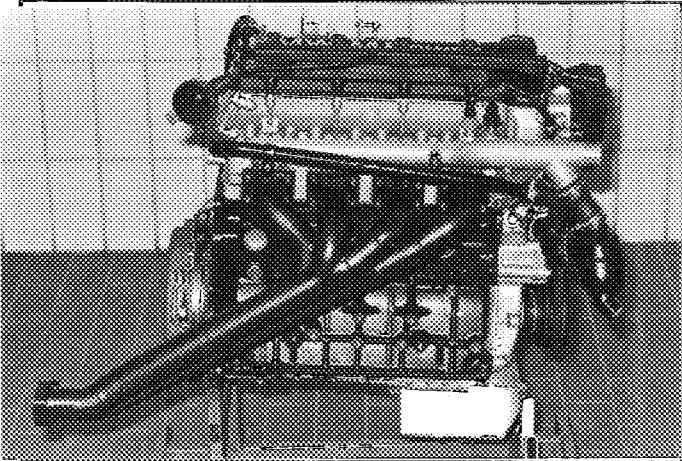

D) Linke Seitenansicht Motor (ausgebaut)
Left hand view of dismantled engine

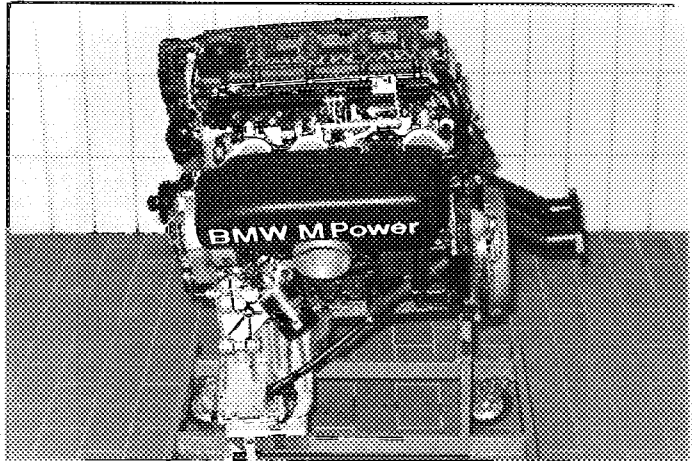

E) Motor im Motorraum
Engine in its compartment

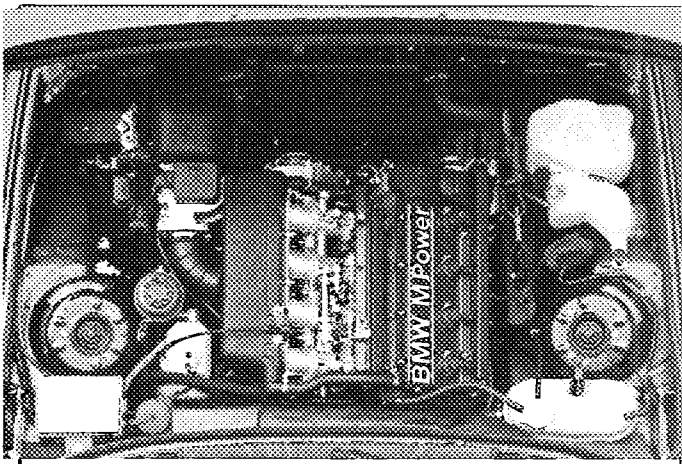

F) Zylinderkopf allein
Bare cylinderhead

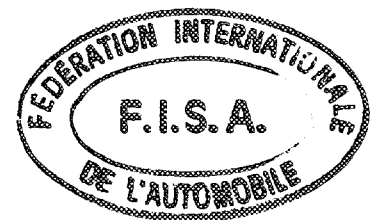
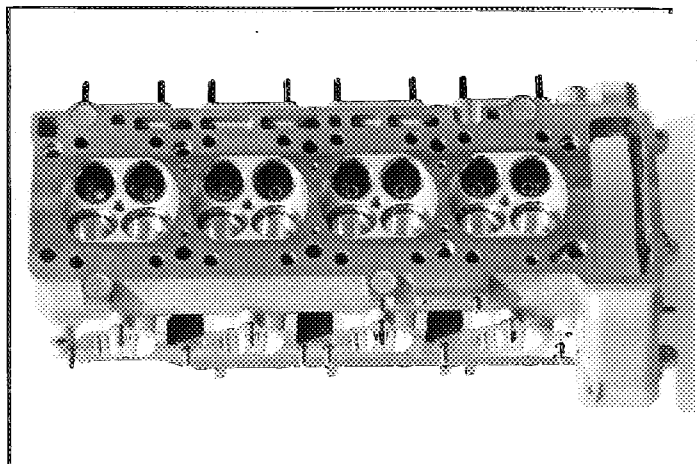

Marke BMW
 Make

Modell M 3
 Model

Homologation Nr. _____
 Homologation Nr.

G) Verbrennungsraum
 Combustion chamber

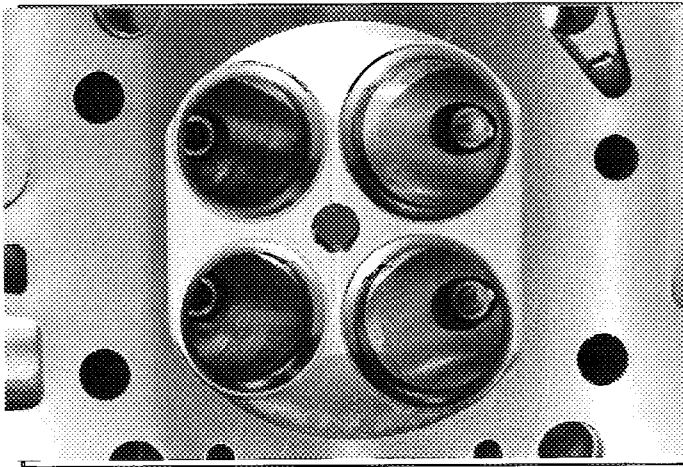

H) Vergaser oder Einspritzsystem
 Carburetor(s) or injection system

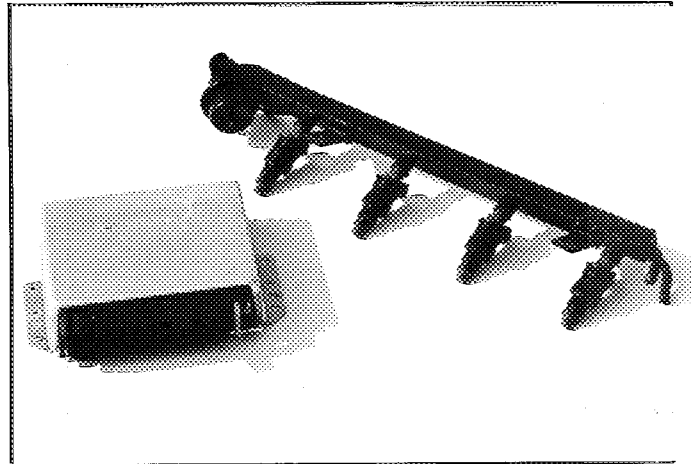

I) Einlaßkrümmer
 Inlet manifold

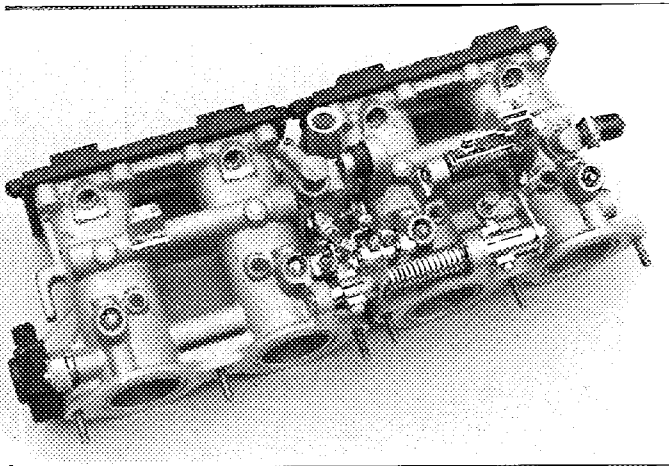

J) Auspuffkrümmer
 Exhaust manifold

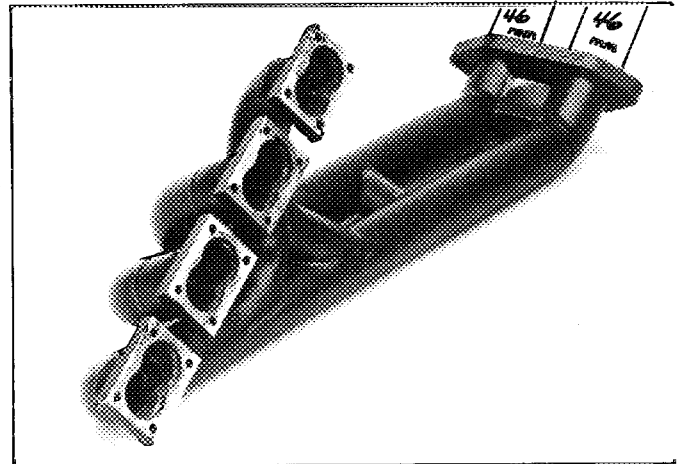

Getriebe
 Transmission

S) Getriebegehäuse und Kupplungsglocke
 Gearbox casing and clutch bellhousing

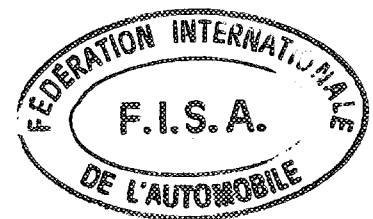
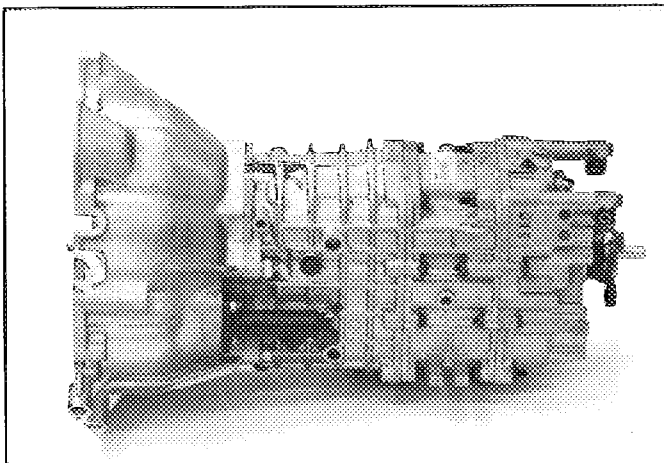

Marke BMW
Make

Modell M 3
Model

Homologation Nr. _____
Homologation Nr.

Radaufhängung
Suspension

T) Vorderachse vollständig ausgebaut
Complete dismantled front running gear

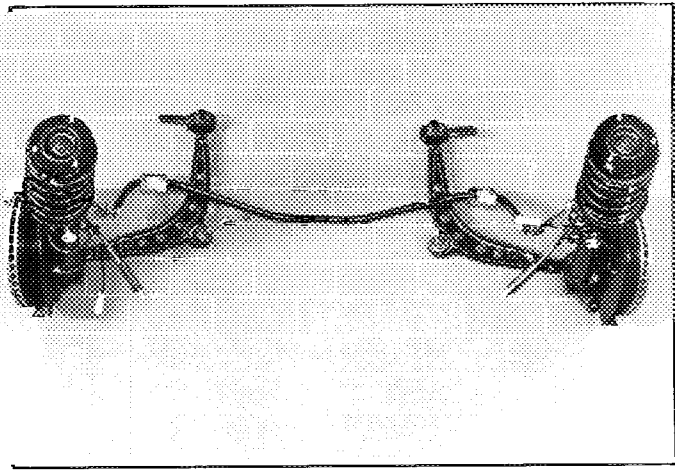

U) Hinterachse vollständig ausgebaut
Complete dismantled rear running gear

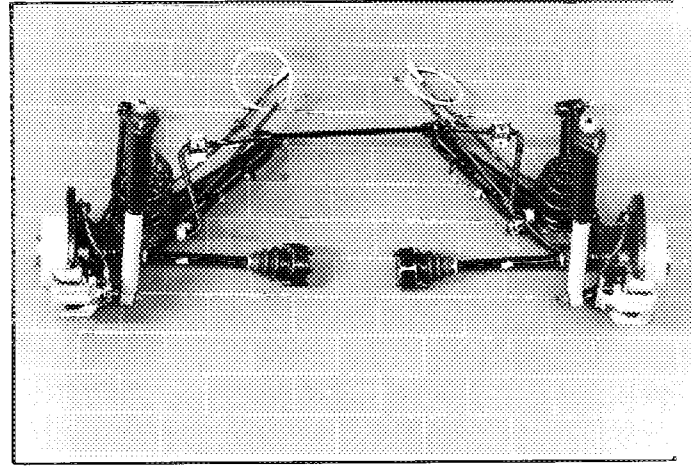

Fahrwerk
Running gear

V) Bremsen vorn
Front brakes

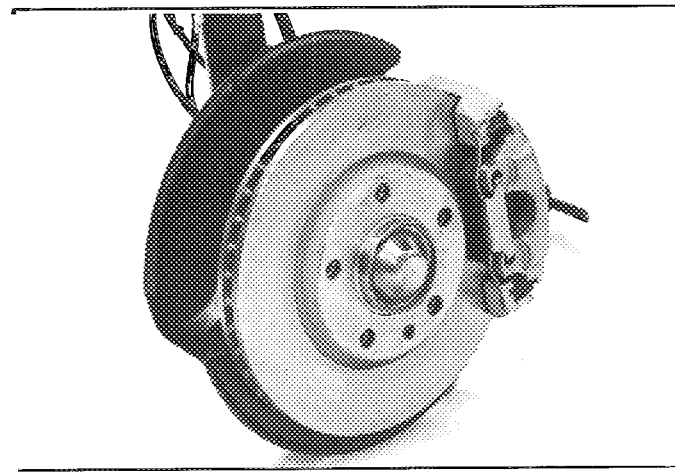

W) Bremsen hinten
Rear brakes

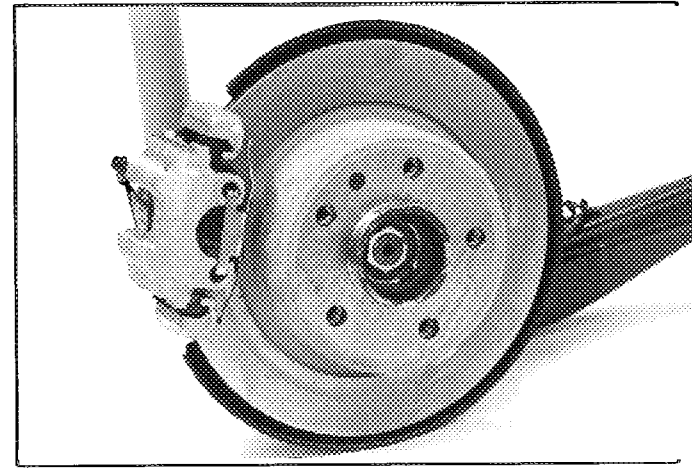

Karosserie
Bodywork

X) Armaturenbrett
Dashboard

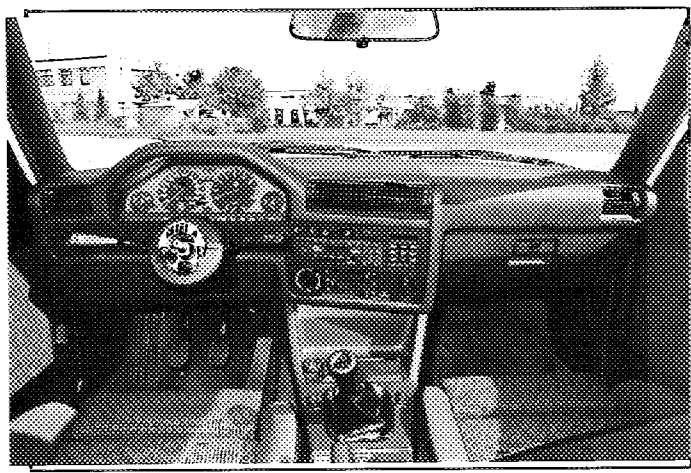

Y) Schiebedach
Sunroof

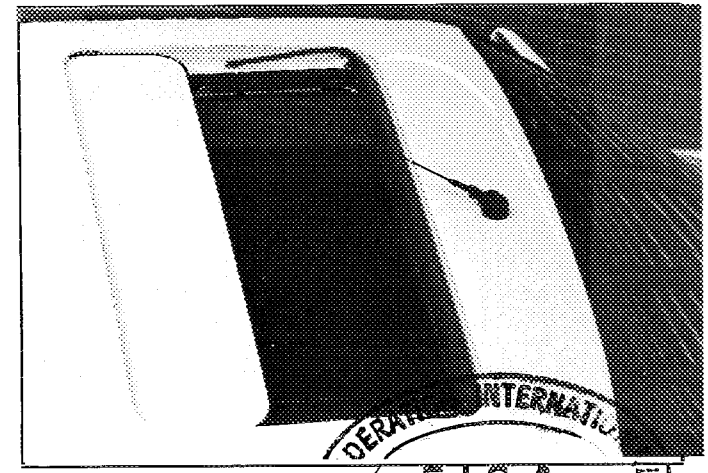

Zeichnungen
 Drawings

Motor
 Engine

I. Zylinderkopfeinlaßöffnung an der Einlaßkrümmerseite (Abmessungstoleranzen: -2% , $+4\%$)
 Cylinder head inlet orifices on manifold side — tolerances on dimensions: -2% , $+4\%$

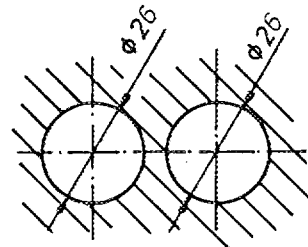
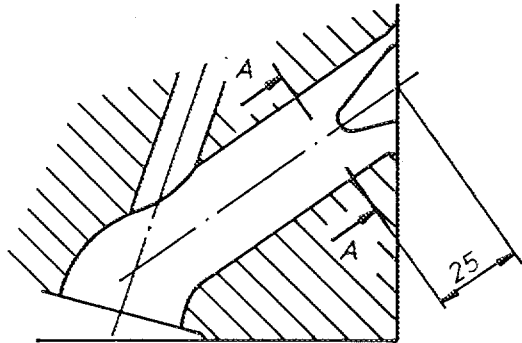

Schnitt A-A

II. Einlaßkrümmeröffnung an der Zylinderkopfseite (Abmessungstoleranzen: -2% , $+4\%$)
 Inlet manifold orifices, cylinder head side — tolerances on dimensions: -2% , $+4\%$

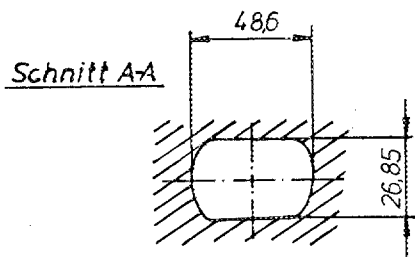

Schnitt AA

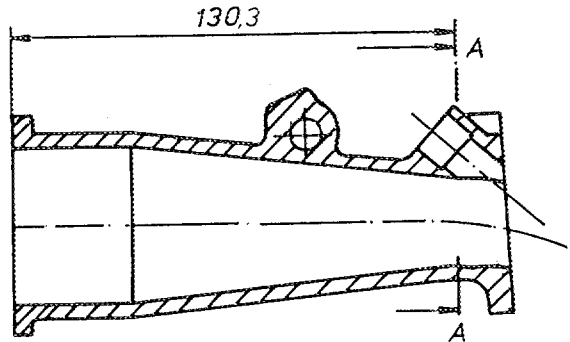

III. Zylinderkopfauslaßöffnung an der Auslaßkrümmerseite (Abmessungstoleranzen: -2% , $+4\%$)
 Cylinder head exhaust orifices on manifold side — tolerances on dimensions: -2% , $+4\%$

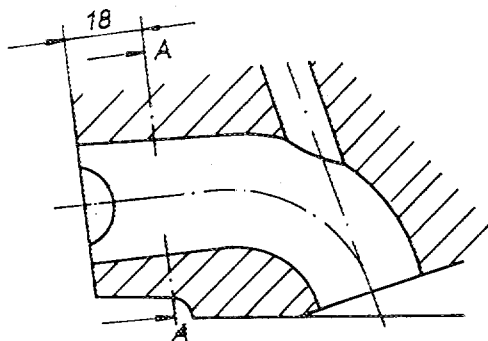

Schnitt A-A

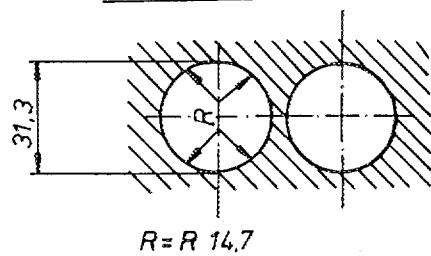

$R=R\ 14,7$

IV. Auslaßkrümmeröffnung an der Zylinderkopfseite (Abmessungstoleranzen: -2% , $+4\%$)
 Exhaust manifold orifices, cylinder head side — tolerances on dimensions: -2% , $+4\%$

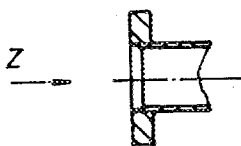

Z

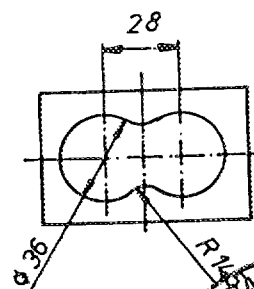

Ansicht Z

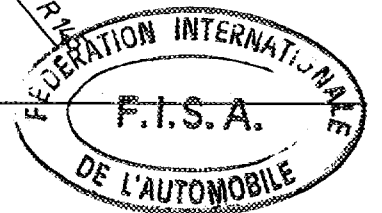

A - 5327

Marke BMW
Make

Modell M 3
Model

Homologation Nr. _____
Homologation No.

Radaufhängung
Suspension

XV. System der Radaufhängung gem. Art. 705 oder anstelle der Fotos T und U
Suspension system according to article 705 or replacing photos T and U

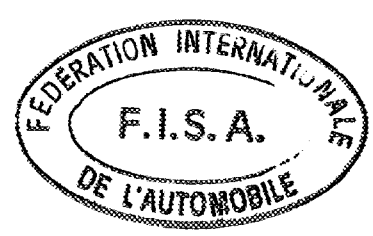

Gruppe **A/B**
Group

Marke BMW
Make

Modell M 3
Model

Innenabmessungen gem. Homoiogationsbestimmungen
Interior dimensions as defined by the Homologation Regulations

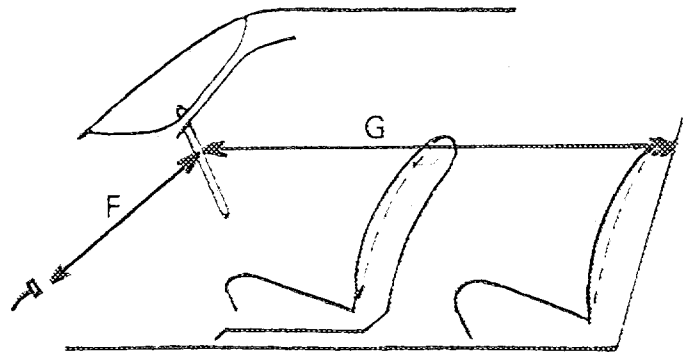
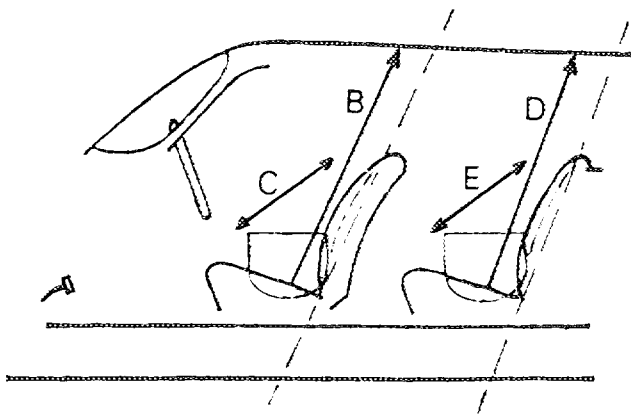

- B Höhe über den Vordersitzen 1010 mm
Height above front seats
- C Breite über den Vordersitzen 1330 mm
Width at front seats
- D Höhe über den Rücksitzen 960 mm
Height above rear seats
- E Breite über den Rücksitzen 1400 mm
Width at rear seats
- F Abstand Lenkrad — Bremspedal 640 mm
Steering wheel — brake pedal
- G Abstand Lenkrad — Hintere Trennwand 1570 mm
Steering wheel — rear bulkhead
- H = F + G = 2210 mm

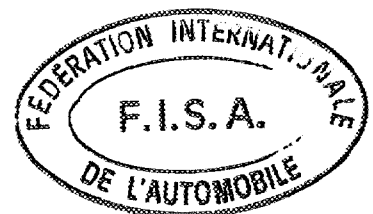

FÉDÉRATION INTERNATIONALE DU SPORT AUTOMOBILE

ONS Oberste Nationale Sportkommission für den Automobilsport in Deutschland GmbH

Homologation Nr.

A - 5327

Nachtrag Nr.
Extension Nr.

01 / 01 V0

Nachtrag zum offiziellen Testblatt der FISA

Form of extension to the official FISA-Homologation

- ET** Normale Weiterentwicklung des Typs: ab Fahrgestell-Nr.: _____
Normal evolution of the type, as from chassis number.
- ES** Sportevolution
Sporting evolution
- VF** Liefervariante
Supply variant
- VO** Ausstattungsvariante
Option variant
- ER** Berichtigung
Erratum

Homologation gültig ab: 01.03.87 in Gruppe: A
Homologation valid as from in group

Hersteller: BMW Motorsport GmbH Modell und Typ: M 3
Manufacturer Model and type

Seite od. Nachtrag Page or ext.	Artikel Art	Beschreibung Description	
Seite 5	401	Sicherheits-Kraftstofftank mit Aufprallschutz / safety fuel cell with underneath protection	Foto 1
	401 b	Kofferraum / luggage compartment	
	401	Catchtank	Foto 2
	401 c	Aluminium	
	401 d	6,5 Liter	
Seite 6	603	Verstärktes Getriebe / reinforced gearbox	Foto 3
Seite 7	605 b	3,15 : 1, 3,25 : 1, 3,46 : 1, 3,64 : 1, 3,73 : 1, 3,91 : 1, 4,10 : 1	
	605 c	41 : 13, 39 : 12, 45 : 13, 40 : 11, 41 : 11, 43 : 11, 41 : 10	
	605 b	4,27 : 1, 4,45 : 1, 4,75 : 1, 5,00 : 1, 5,28 : 1	
	605 c	47 : 11, 49 : 11, 38 : 8, 40 : 8, 37 : 7	
	606 A	Verstärkte Antriebswellen zwischen Hinterachsgetriebe und Radnabe / reinforced driveshafts between rear axle housing and wheelhubs	Foto 4

[Handwritten Signature]

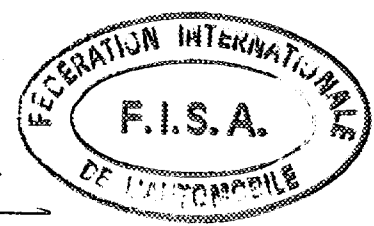

Marke BMW
Make

Modell M 3
Model

Homologations Nr. A - 5327
Homologation Nr.

Nachtrag Nr. 01 / 01 V0
Ext. Nr.

Seite od. Nachtrag Page or ext.	Artikel Art.	Beschreibung Description	
Seite 7	701 A	Verstärkte Vorderradaufhängung mit 5 Radbolzen, mit dem Originalteil austauschbar / reinforced front suspension with 5 wheelbolts, interchangeable with original part	Foto 5
	701 A	Zentralbefestigung für Vorderräder / central knock off system for front wheels	Foto 6
	701 A	Federbeinstützlager, einstellbar / top mounting plate, adjustable	Foto 7
	701 A	Verstärkte Vorderradaufhängung mit 5 Radbolzen / reinforced front suspension with 5 wheelbolts interchangable with original part	Foto 9
	701 A	Verstärkter Stabilisator, vorne / reinforced anti-roll bar front	Foto 10
	701 A	Verstärkter Querlenker / reinforced wishbone	Foto 11
	701 B	Verstärkte Hinterradaufhängung mit 5 Radbolzen, mit dem Originalteil austauschbar / reinforced rear suspension with 5 wheelbolts, interchangeable with original part	Foto 12
	701 B	Verstärkter Stabilisator, hinten / reinforced anti-roll bar, rear	Foto 13
	701 B	Zentralbefestigung für Hinterräder / central knock off system rear wheels	Foto 14
	701 B	Verstärkte Stoßdämpferaufnahme, hinten / reinforced shockabsorber mounting, rear	Foto 15
	701 B	Verstärkte Hinterradaufhängung mit 5 Radbolzen, mit dem Originalteil austauschbar / reinforced rear suspension with 5 wheelbolts, interchangeable with the original part	Foto 23



Marke BMW
 Make

Modell M 3
 Model

Homologations Nr. A - 5327
 Homologation Nr.

Nachtrag Nr. 01 / 01 V0
 Ext. Nr.

Seite od. Nachtrag Page or ext.	Artikel Art.	Beschreibung Description	
Seite 8	707 B	Feder/Dämpfer Einheit, hinten / spring damper unit, rear	Foto 17
		Federlage geändert / position of the spring altered	
	803	Fußhebelwerk / pedal assembly	Foto 18
	803 A	Hydraulic mit oder ohne ABS / Hydraulic with or without ABS	
	803 B	2	
	803 B1	Durchmesser / bore 15,9 mm 17,8 mm 19,0 mm 21,0 mm, 22,2 mm, 23,8 mm	
	803 C	Nein / no	
	803 D	Ja / yes	
	803 D1	Waagebalken im Bremspedal / balance bar in brakepedal	Foto 19
	803 D1	Verstellung auf Getriebetunnel /adjustable from gear box tunnel	
Seite 9		Foto V 1 + Foto V 1a front	Foto W 1 + W 7 rear
	803 E	4	4
	803 E1	38/42 mm	31,7 mm + 36,0 + 38,1 + 33,9 / 38,0 mm
	803 G1	2	2
	803 G2	1	1
	803 G3	Aluminium	Aluminium
	803 G4	32 ± 1,0 mm	20,7 ± 1,0 mm
	803 G5	332 ± 1,0 mm	280 ± 1,0 mm
	803 G6	332 ± 1,5 mm	280 ± 1,5 mm
	803 G7	226 ± 1,5 mm	178,4 ± 1,5 mm
803 G8	132 ± 1,5 mm	112,25 ± 1,5 mm	
803 G9	ja	ja	
803G10	955,39 cm ²	753,18 cm ²	

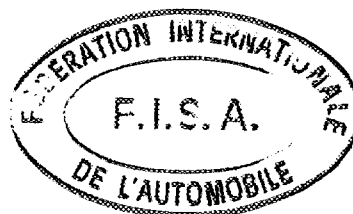

Marke
Make

BMW

Modell
Model

M 3

Homologations Nr.
Homologation Nr.

A - 5327

Nachtrag Nr.
Ext. Nr.

01 / 01 10

Seite od. Nachtrag Page or ext.	Artikel Art.	Beschreibung Description	
Seite 8		Foto V 2 + Foto V 2a	Foto W 2 + Foto W 2a
	803 E	4	4
	803 E1	42,8 mm	33,9 mm + 38 mm
	803 G1	2	2
	803 G2	1	1
	803 G3	Aluminium	Aluminium
	803 G4	32 ± 1,0 mm	22,2 ± 1,0 mm
	803 G5	331 ± 1,0 mm	280 ± 1,0 mm
	803 G6	330 ± 1,5 mm	279 ± 1,5 mm
	803 G7	194 ± 1,5 mm	178 ± 1,5 mm
	803 G8	130 ± 1,5 mm	62 ± 1,5 mm
	803 G9	ja / yes	ja / yes
	803G10	1154,54 cm ²	755,4 cm ²
		Foto V 3	Foto W 3 + Foto W 3a
	803 E	4	4
	803 E1	44,5 mm	31,7 mm + 38,1 mm
	803 G1	2	2
	803 G2	1	1
	803 G3	Aluminium	Aluminium
	803 G4	31,75 ± 1,0 mm	20 ± 1,0 mm
	803 G5	330,2 ± 1,0 mm	302 ± 1,0 mm
	803 G6	332 ± 1,5 mm	300 ± 1,5 mm
	803 G7	198 ± 1,5 mm	195 ± 1,5 mm
	803 G8	126 ± 1,5 mm	113 ± 1,5 mm
	803 G9	ja	ja
	803G10	1121,75 cm ²	858,75 cm ²



Marke BMW
Make

Modell M 3
Model

Homologations Nr. A-5327
Homologation Nr.

01/01V0

Nachtrag Nr. _____
Ext. Nr.

Seite od. Nachtrag Page or ext.	Artikel Art	Beschreibung Description	
Seite 9		Foto V 4 + Foto V 4a	Foto V 5 + Foto V 1a
	803 G4	31,75 ± 1,0	32 ± 1,0 mm
	803 G5	330,2 ± 1,0	332 ± 1,0 mm
	803 G6	332,0 ± 1,5	332 ± 1,5 mm
	803 G7	198 ± 1,5	226 ± 1,5 mm
	803 G8	126 ± 1,5	132 ± 1,5 mm
	803 G9	ja	ja
	803G10	1121,75 cm ²	955,39 cm ²
	803 H1	Hydraulisch / hydraulic	Foto 20
	804	Verstärkte Lenksäule / reinforced lower steering shaft	Foto 21
	804 A	Verstärkte Zahnstangenlenkung / reinforced rack and pinion steering	Foto 22
	804 B	17,025 : 1	
	804 C	Nein / No	
		Foto W 4 + Foto W 1a	
	803 G4	22,2 ± 1,0 mm	
	803 G5	280 ± 1,0 mm	
	803 G6	280 ± 1,5 mm	
	803 G7	178,4 ± 1,5 mm	
	803 G8	112,25 ± 1,5 mm	
	803 G9	ja	
	803G10	753,18 cm ²	

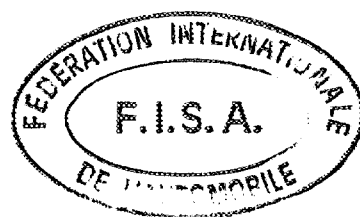

Seite od. Nachtrag Page or ext	Artikel Art	Beschreibung Description
Seite 9 page 9		Foto V 6 + V 7
	803 E	4
	803 E1	38,1 / 42,7
	803 G1	2
	803 G2	1
	803 G3	Aluminium
	803 G4	32,0 ± 01,0 mm
	803 G5	332 ± 1,0 mm
	803 G6	332 ± 1,5 mm
	803 G7	232 ± 1,5 mm
	803 G8	131 ± 1,5 mm
	803 G9	ja / yes
	803G10	912,51 cm ²
	803 H1	hydraulisch / hydraulic
		Foto V 8
	803 E	4
	803 E1	41/44 mm
	803 G1	2
	803 G2	1
	803 G3	Aluminium
	803 G8	130 ± 1,5 mm
		Foto W 5 + W 6 + W 3a
		4
		38,1 / 41,7 or 36,0 or 32,0
		2
		1
		Aluminium
		28,0 ± 1,0 mm
		25,4 ± 1,0 mm
		304 ± 1,0 mm
		304 ± 1,5 mm
		204 ± 1,5 mm
		131 ± 1,5 mm
		ja / yes
		821,90 cm ²
		Foto 24

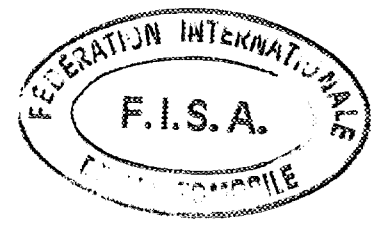

Marke BMW
Make

Modell M 3
Model

Homologations Nr. A-5327
Homologation Nr.

Fotos
Photos

Nachtrag Nr. 01/01V0
Ext. Nr.



Foto 1



Foto 2

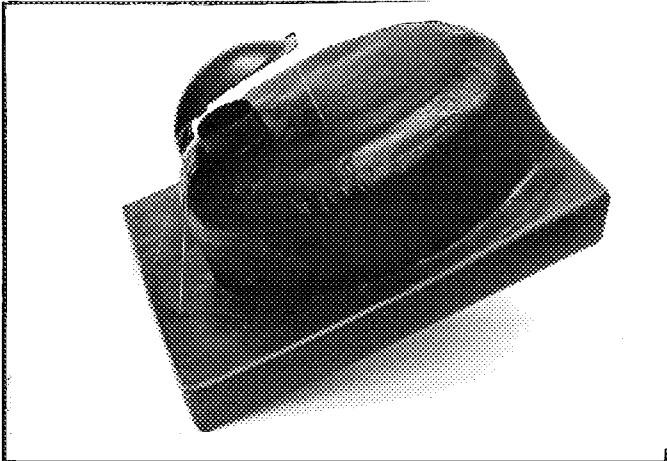

Foto 3

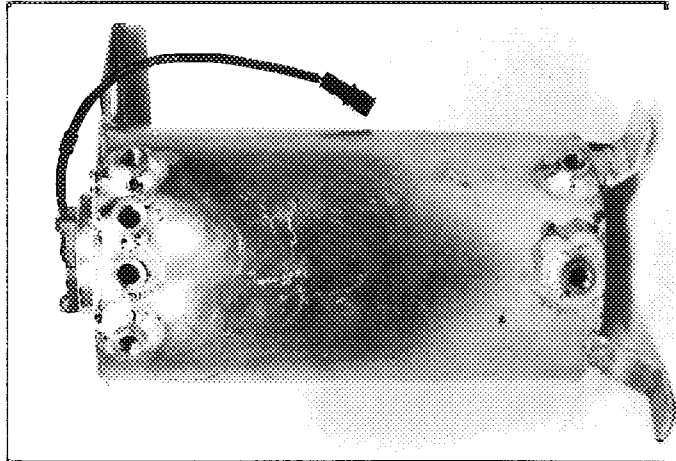

Foto 4

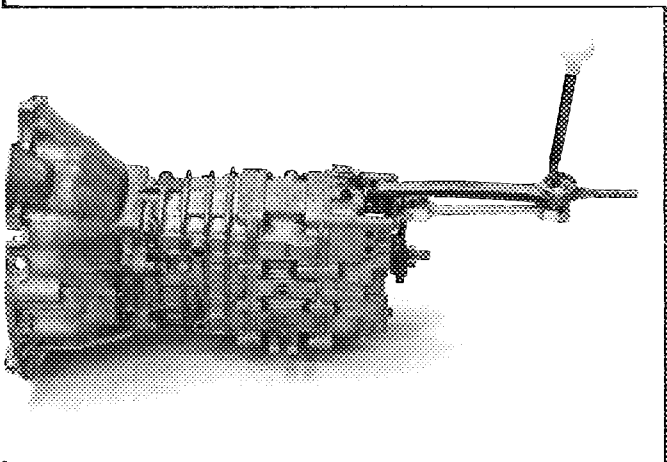

Foto 5

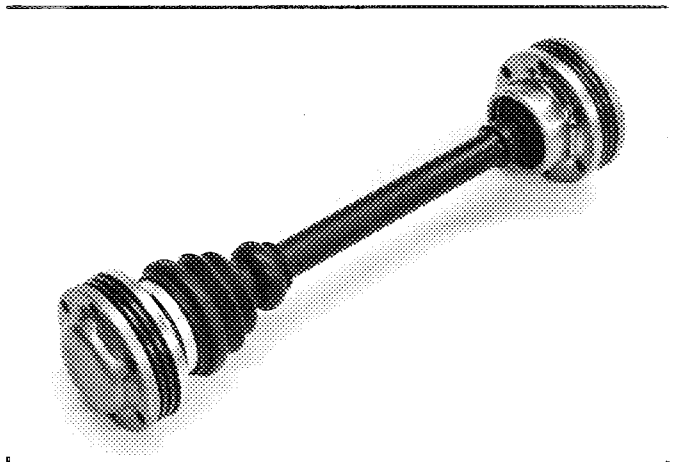

Foto 6

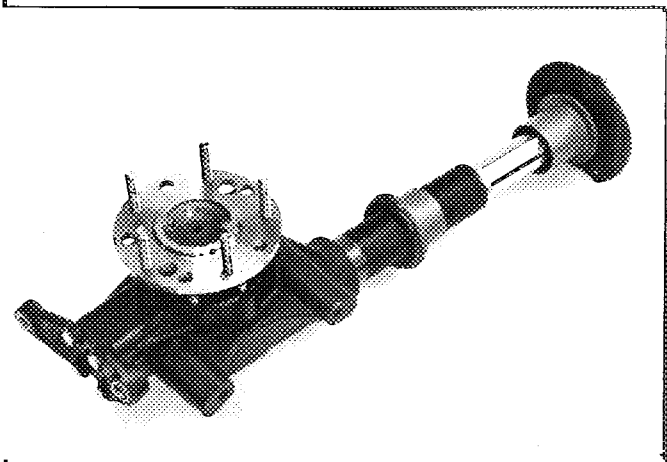

Marke BMW
Make

Modell M 3
Model

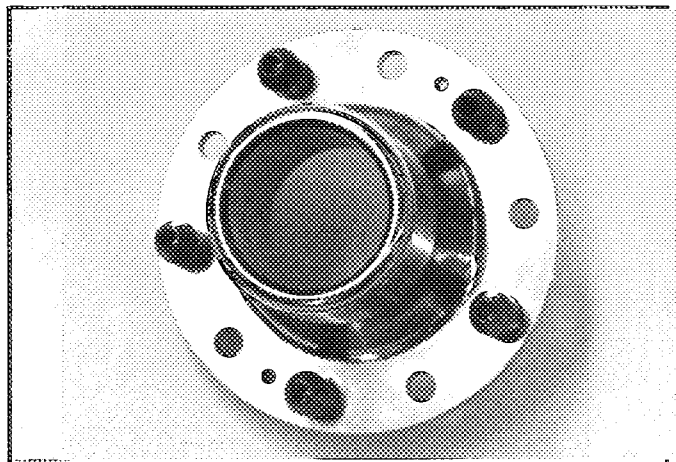
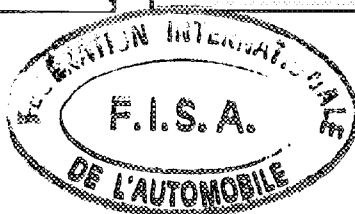
Homologations Nr. A - 5327
Homologation Nr.

01 / 01 V0

Fotos
Photos

Nachtrag Nr. _____
Ext. Nr.



Foto 7



Foto 9

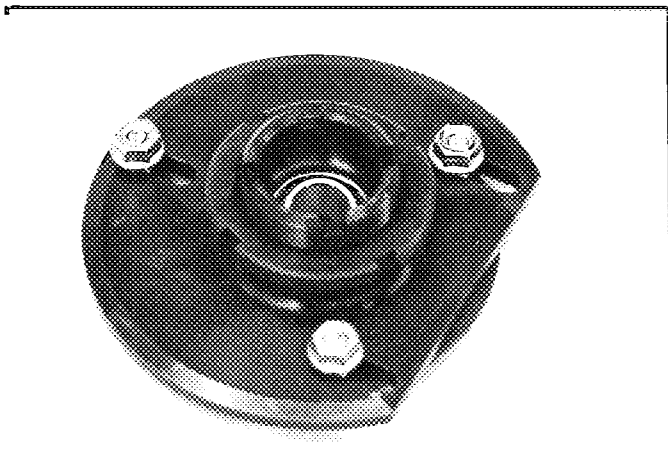

Foto 10

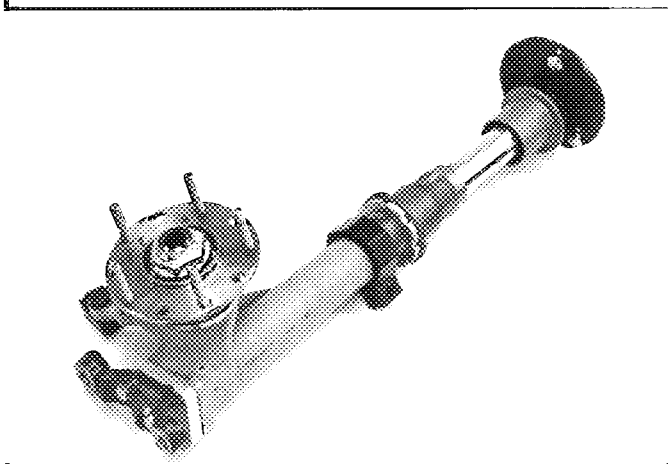
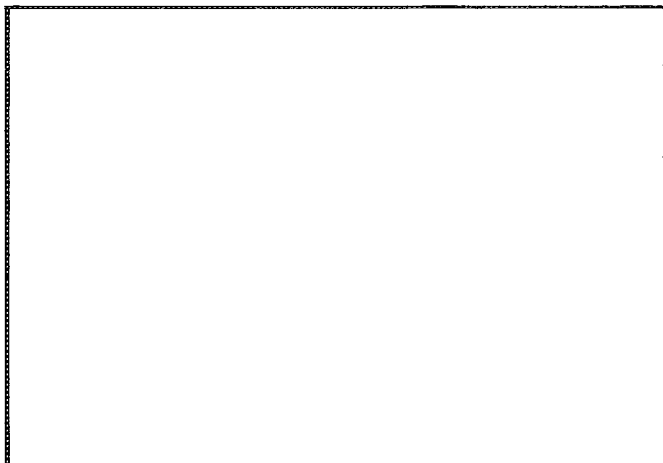

Foto 11

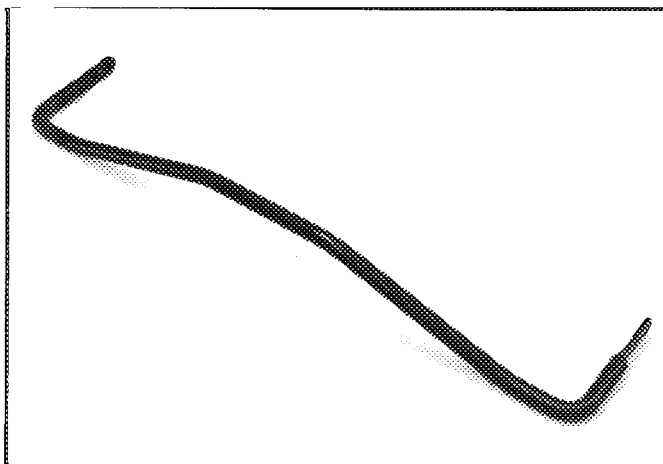

Foto 12

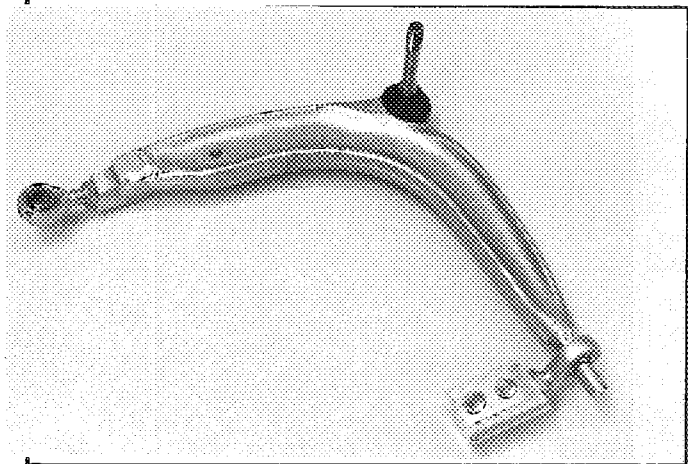

A-5327

Marke BMW
Make

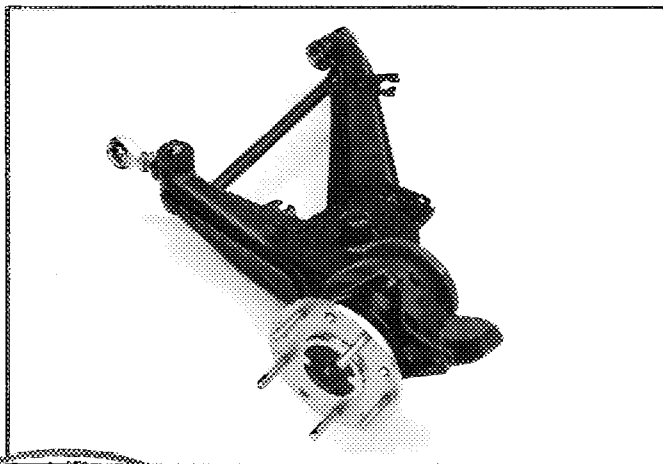
Modell M 3
Model

Homologations Nr. _____
Homologation Nr.

Fotos
Photos

Nachtrag Nr. 01/01V0
Ext. Nr.



Foto 13



Foto 14

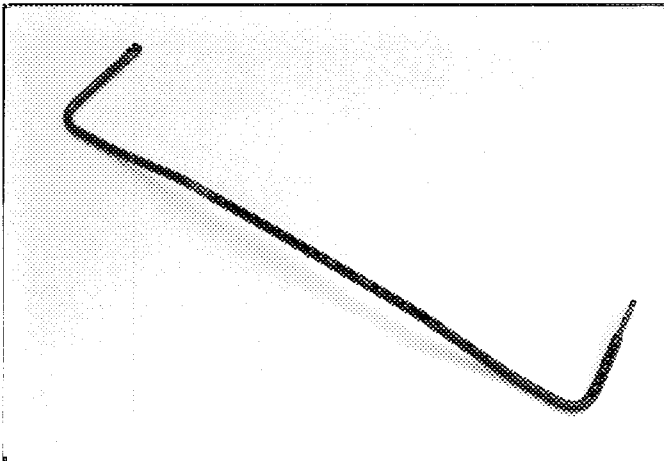

Foto 15

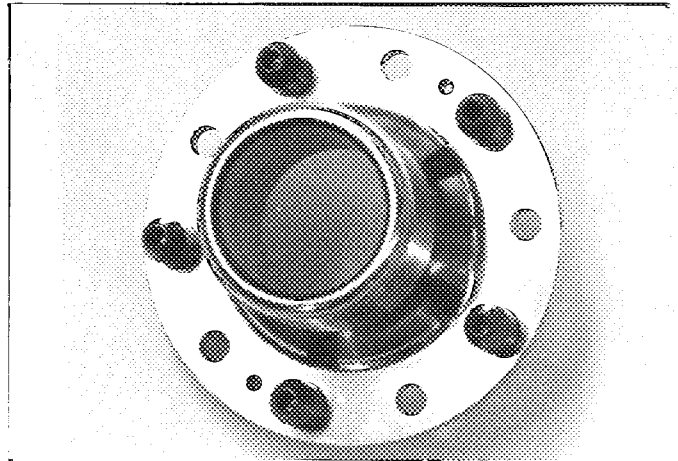

Foto 17



Foto 18

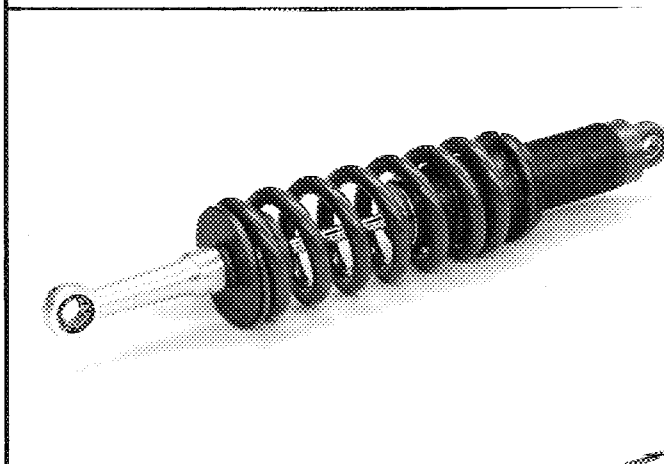
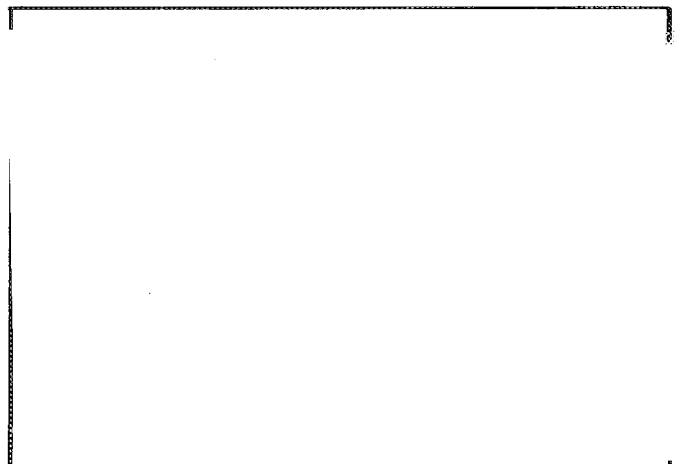

Marke BMW
Make

Modell M 3
Model

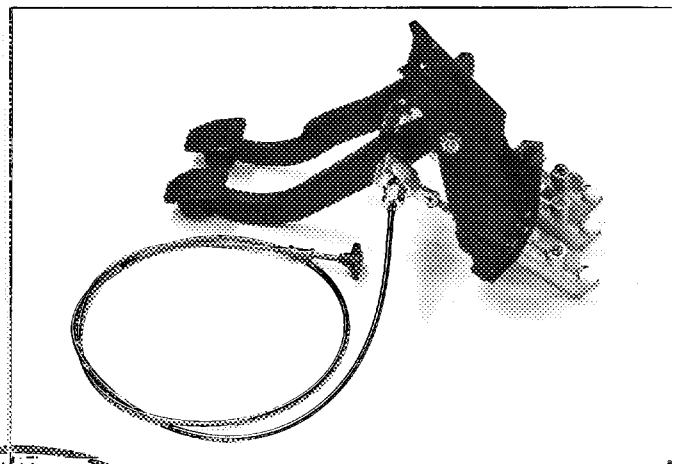
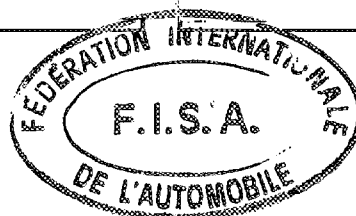
Homologations Nr. A-5327
Homologation Nr.

Fotos
Photos

Nachtrag Nr. 01/01V0
Ext. Nr.



Foto V 1a



Foto W 1a

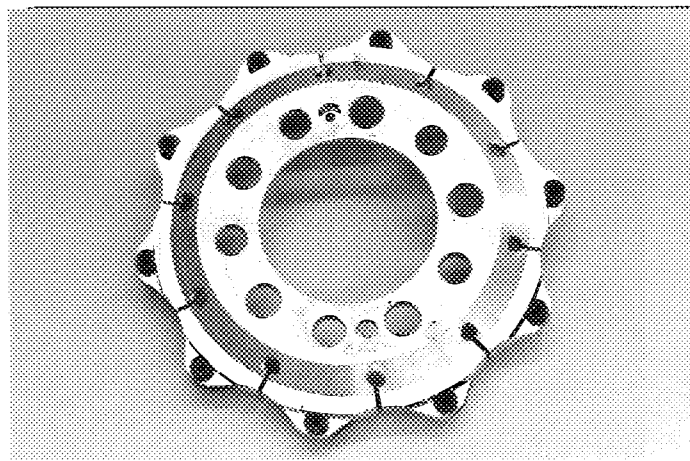

Foto V 4a

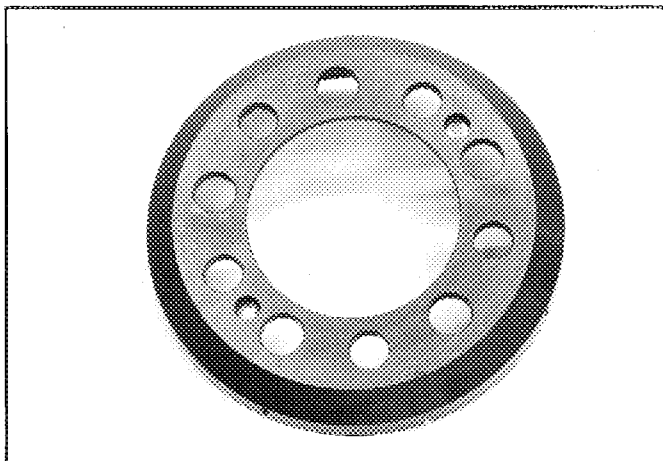

Foto W 2a

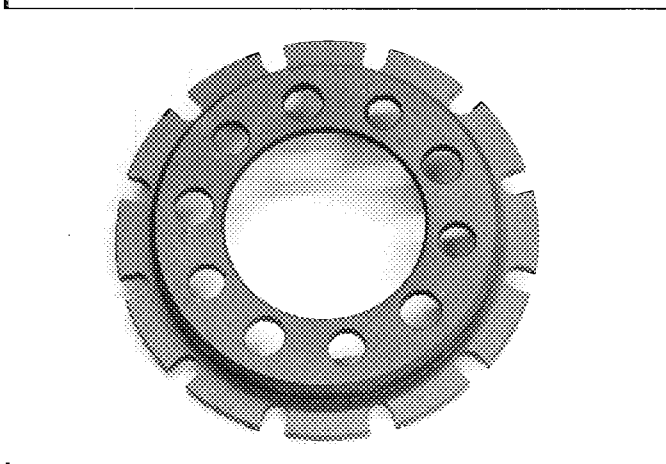

Foto 2a

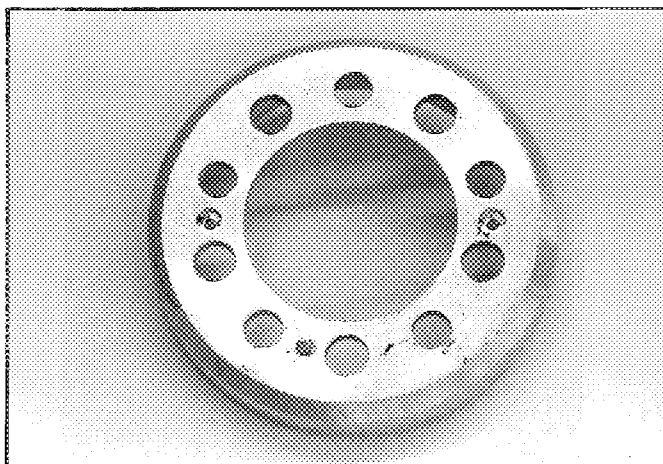

Foto W 3a

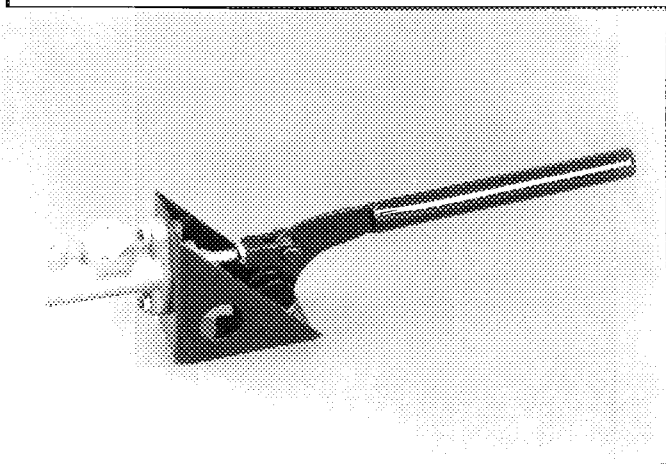

A - 5327

Marke BMW
Make

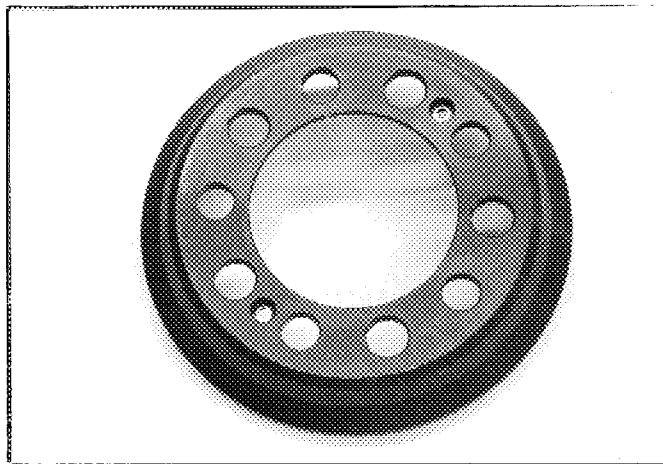
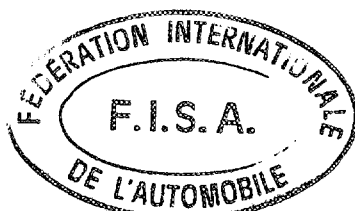
Modell M 3
Model

Homologations Nr. _____
Homologation Nr.

Fotos
Photos

Nachtrag Nr. 01 / 01 V0
Ext. Nr.



Foto 19



Foto V 1

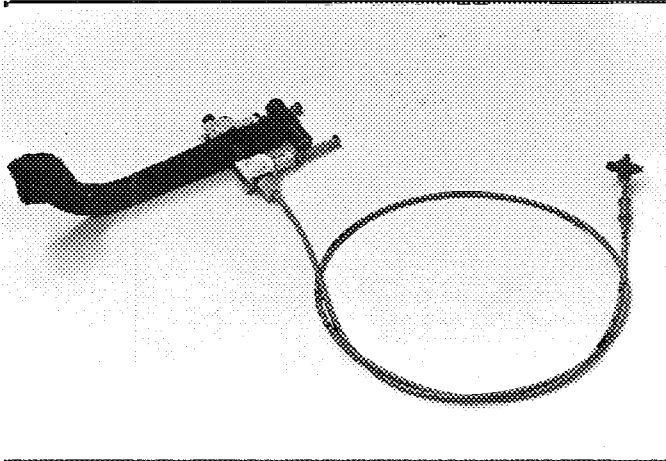

Foto W 1

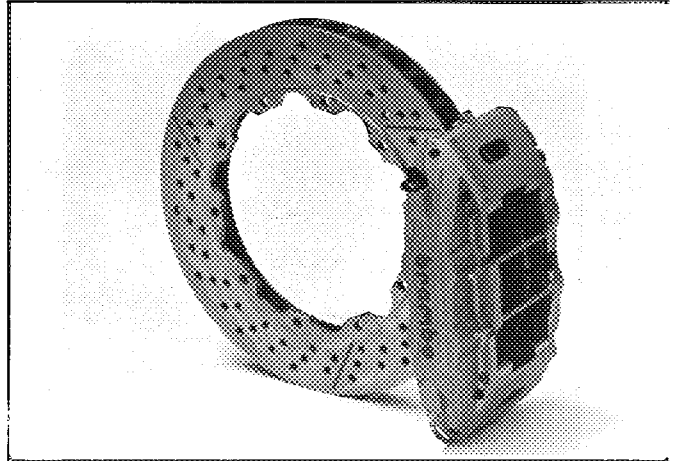

Foto V 2

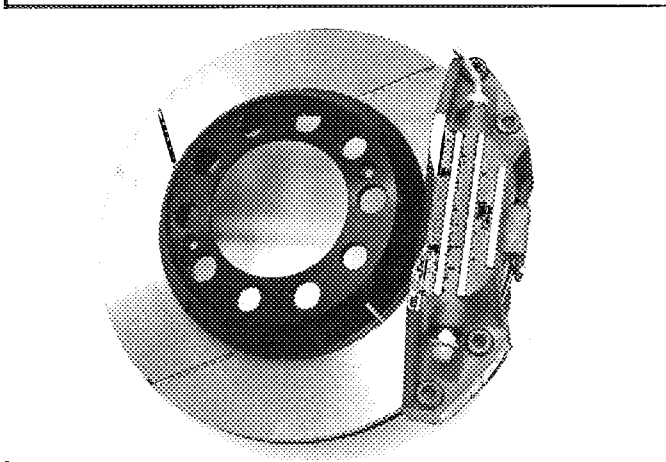

Foto W 2

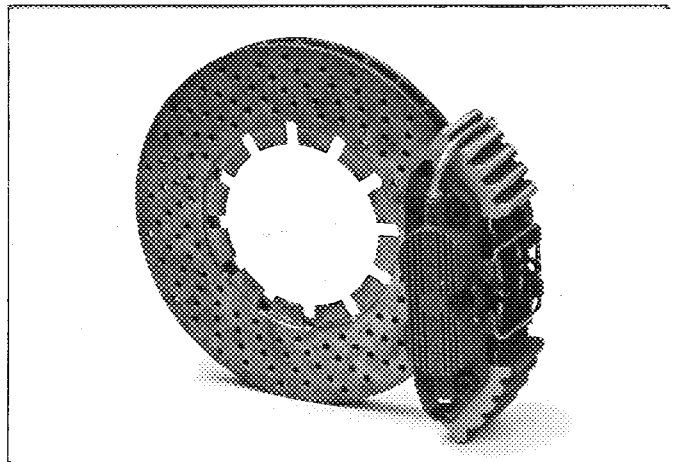

Foto V 3

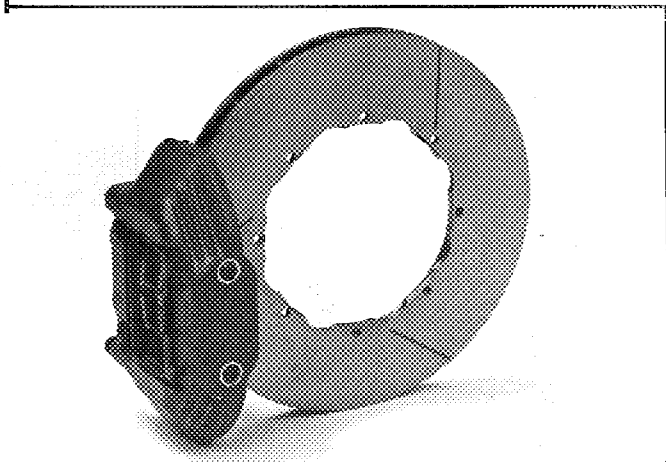

Marke BMW
Make

Modell M 3
Model

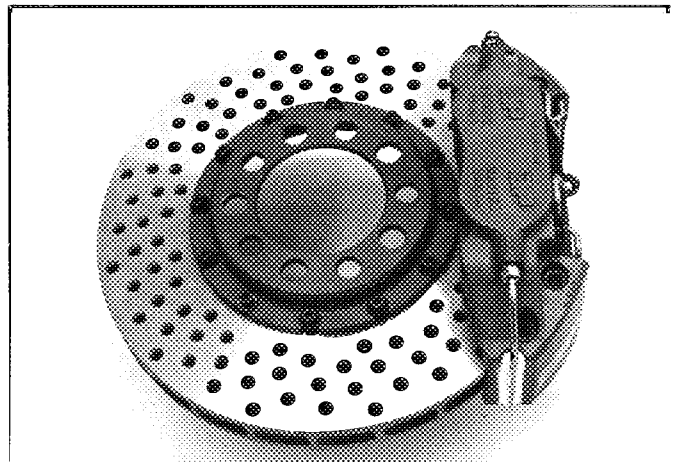
Homologations Nr. A-5327
Homologation Nr.

Fotos
Photos

Nachtrag Nr. 01/01V0
Ext. Nr.



Foto W 3



Foto V 4

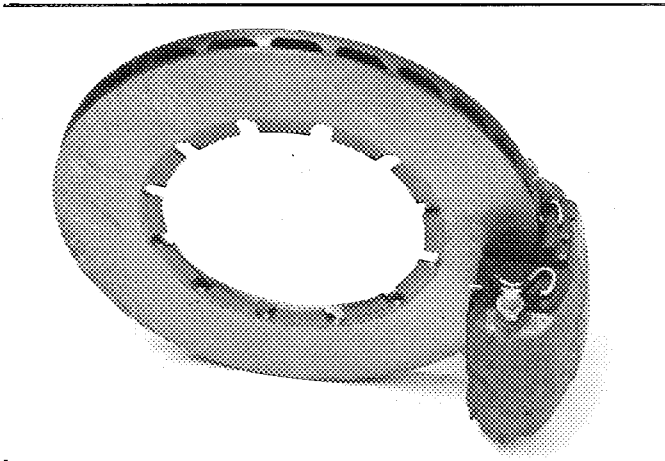

Foto V 5

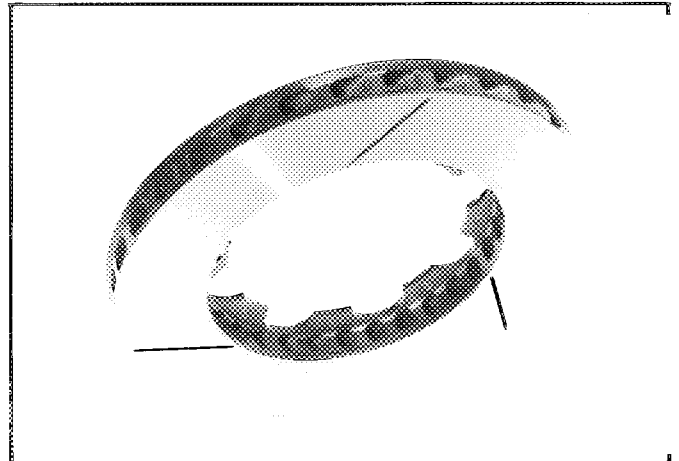

Foto 20

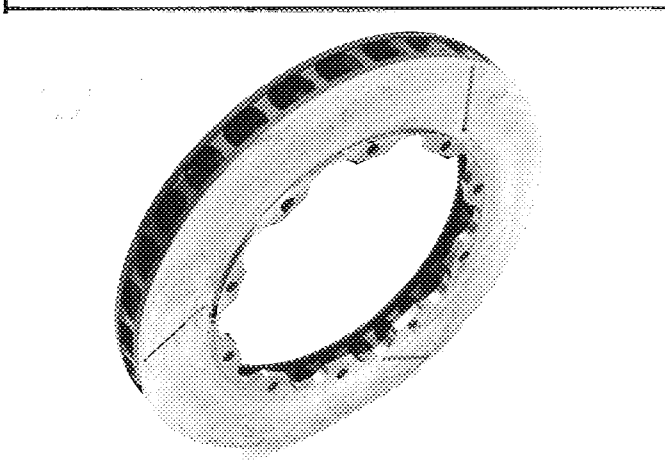

Foto 21

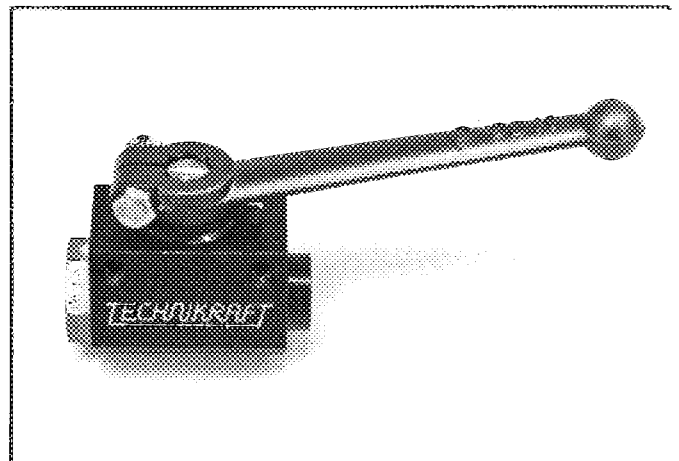

Foto 22

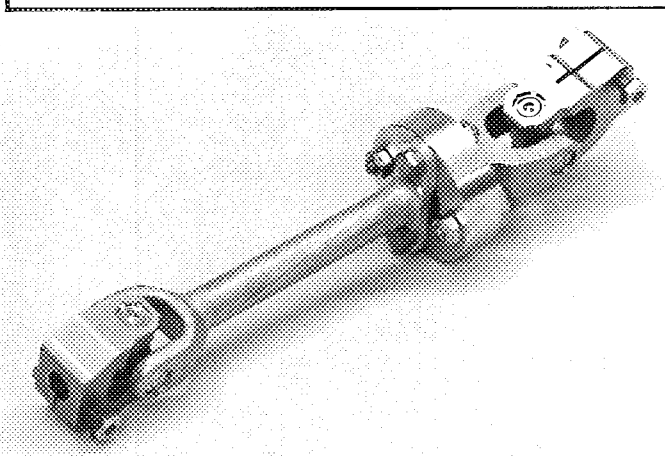

Marke BMW
Make

Modell M 3
Model

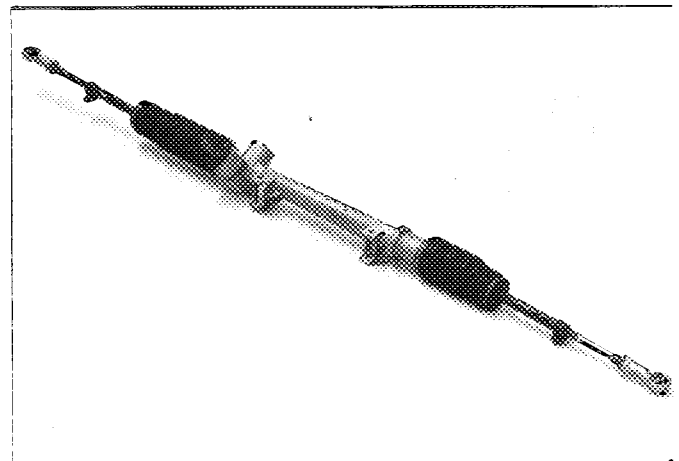
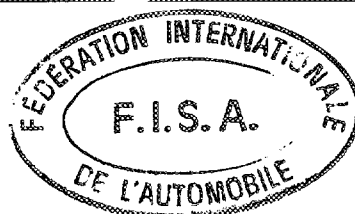
Homologations Nr. A-5327
Homologation Nr.

Fotos
Photos

Nachtrag Nr. 01/01V0
Ext. Nr.



Foto 23



Foto V 4

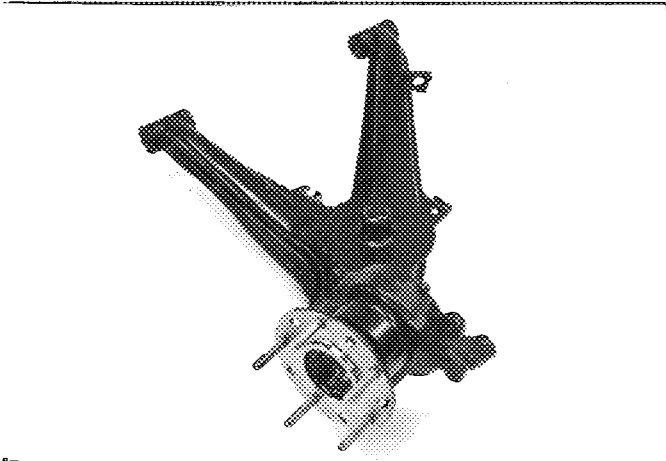

Foto V 7

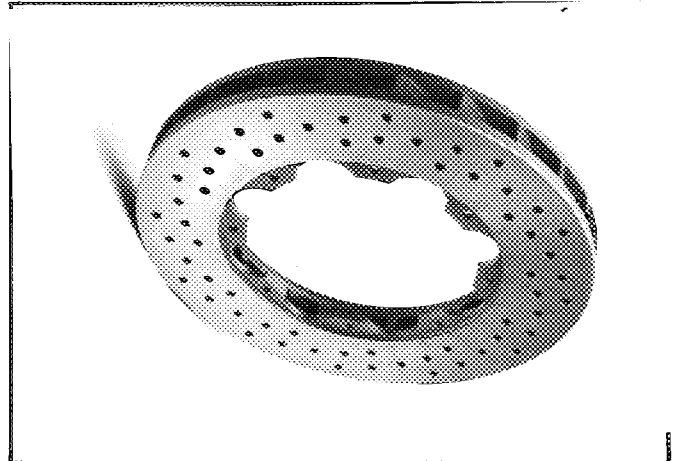

Foto V 2a

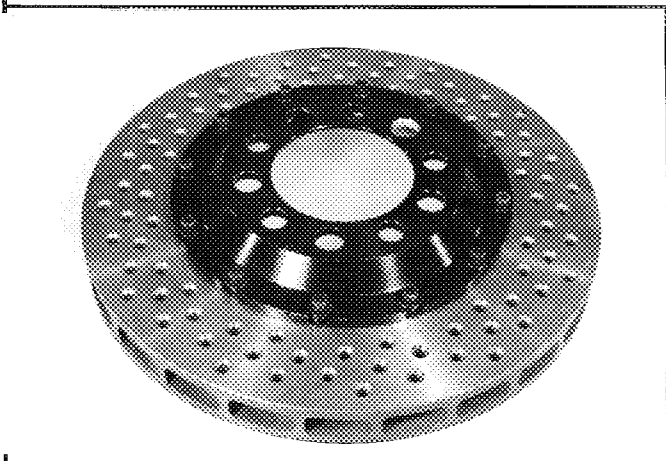

Marke BMW
Make

Modell M 3
Model

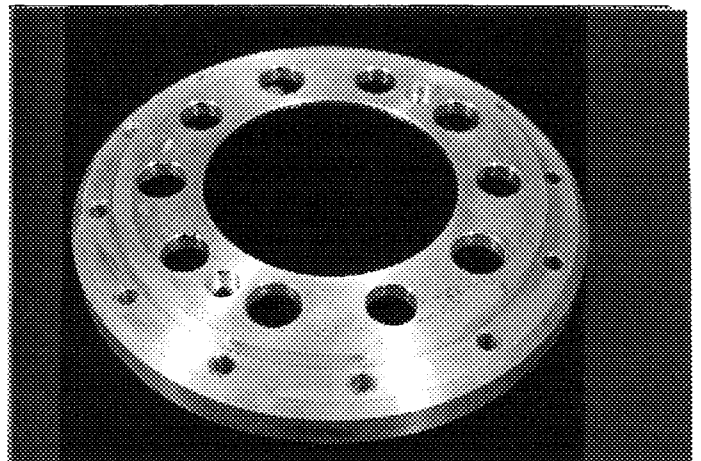
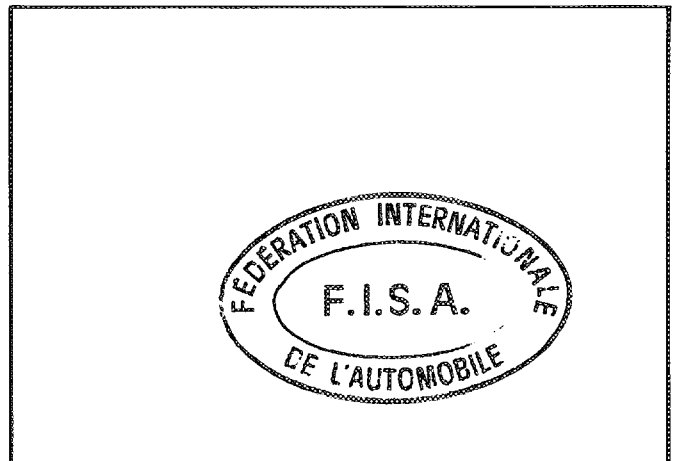
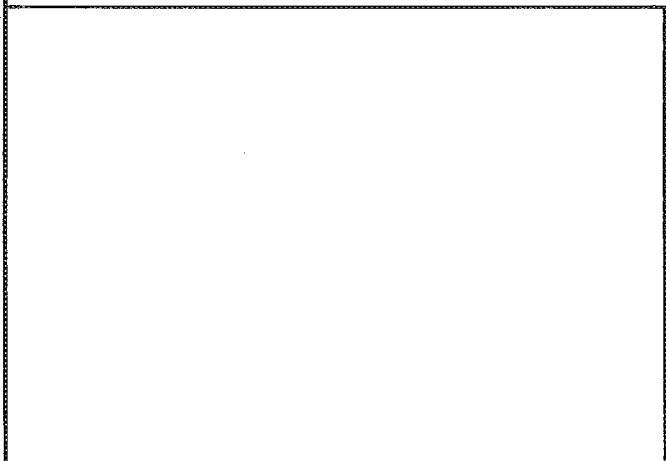
Homologations Nr. A - 5327
Homologation Nr.

01 / 01 V0

Fotos
Photos

Nachtrag Nr. _____
Ext. Nr.



Foto V 6



Foto W 6

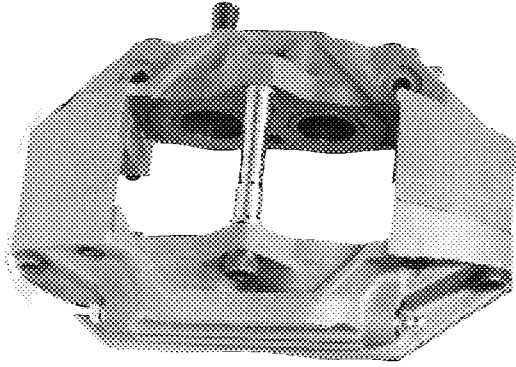

Foto V 8

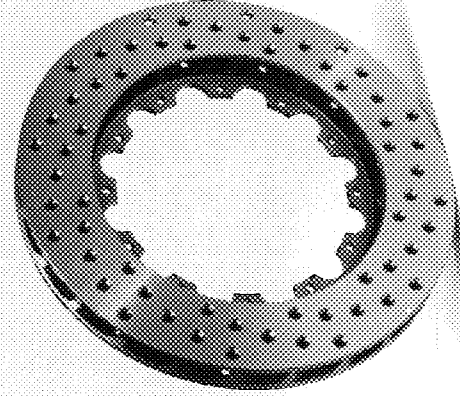

Foto W 7

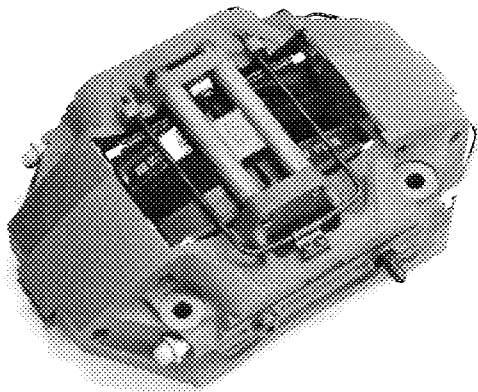

Foto W 5

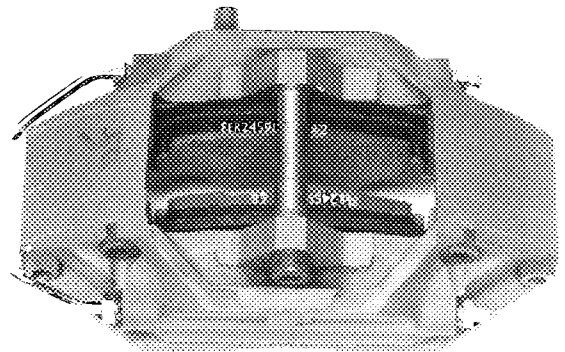

A - 5327

02 / 01 VF

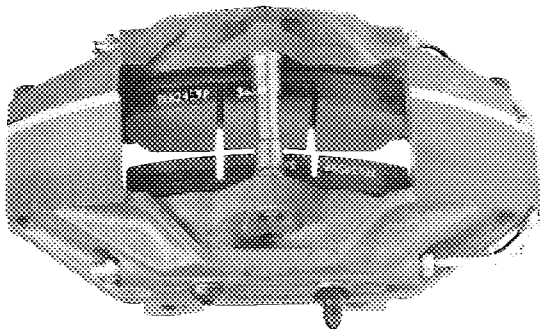
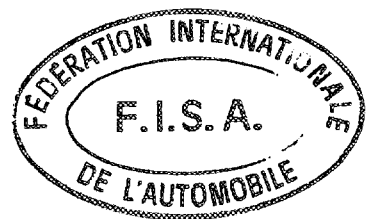
Nachtrag zum offiziellen Testblatt der FISA

Form of extension to the official FISA-Homologation

- ET** Normale Weiterentwicklung des Typs: ab Fahrgestell -Nr.: _____
Normal evolution of the type: as from chassis number:
- ES** Sportevolution
Sporting evolution
- VF** Liefervariante
Supply variant
- VO** Ausstattungsvariante
Option variant
- ER** Berichtigung
Erratum

Homologation gültig ab: 01.03.1987 in Gruppe: A
Homologation valid as from in group

Hersteller: BMW Modell und Typ: M 3
Manufacturer Model and type

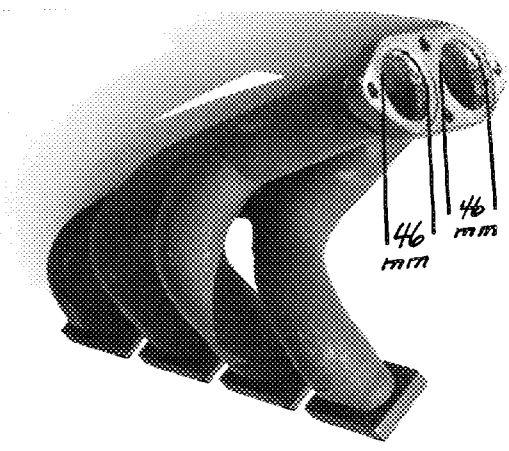
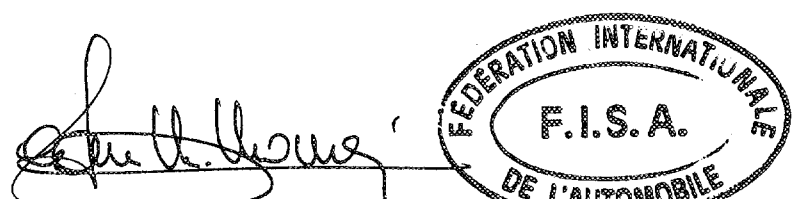
Seite od. Nachtrag Page or ext.	Artikel Art.	Beschreibung Description
Seite 12	Foto J	Auspuffkrümmer / exhaust manifold
		
		

Homologation Nr.

A - 5327

Nachtrag Nr.
Extension Nr.

03 / 01 ER

Nachtrag zum offiziellen Testblatt der FISA

Form of extension to the official FISA-Homologation

- ET** Normale Weiterentwicklung des Typs: ab Fahrgestell -Nr.: _____
Normal evolution of the type: as from chassis number:
- ES** Sportevolution
Sporting evolution
- VF** Liefervariante
Supply variant
- VO** Ausstattungsvariante
Option variant
- ER** Berichtigung
Erratum

Homologation gültig ab: 01.05.1987 in Gruppe: A
Homologation valid as from in group

Hersteller: BMW Motorsport GmbH Modell und Typ: M3
Manufacturer Model and type

Seite od. Nachtrag Page or ext.	Artikel Art.	Beschreibung Description
Seite 1		<p>Neues Foto A / new photo A</p> <div data-bbox="598 1444 1284 1915" data-label="Image"> </div> <p>Foto / photo A</p>

Erster Vorsitzender

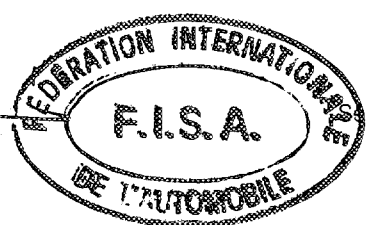

Nachtrag zum offiziellen Testblatt der FISA

Form of extension to the official FISA-Homologation

- ET** Normale Weiterentwicklung des Typs: ab Fahrgestell -Nr.: _____
Normal evolution of the type: as from chassis number:
- ES** Sportevolution
Sporting evolution
- VF** Liefervariante
Supply variant
- VO** Ausstattungsvariante
Option variant
- ER** Berichtigung
Erratum

NON VALABLE EN RALLYE
NOT VALID FOR RALLY

Homologation gültig ab: 01. Mai 1987 in Gruppe: A
Homologation valid as from: _____ in group: _____

Hersteller: BMW Motorsport GmbH Modell und Typ: M3
Manufacturer: _____ Model and type: _____

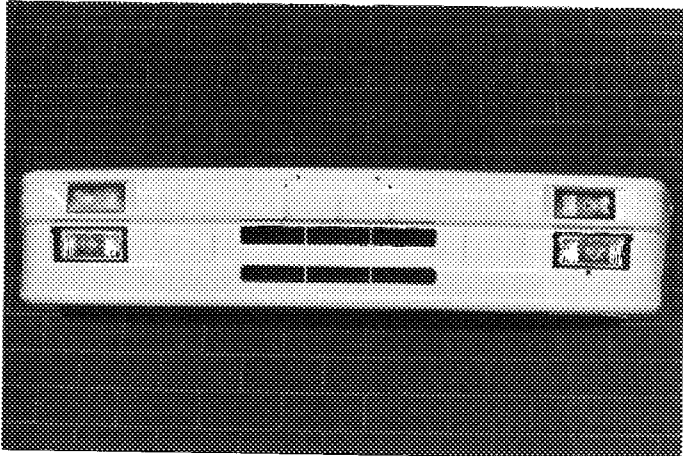
Seite od. Nachtrag Page or ext.	Artikel Art.	Beschreibung Description
Seite 1	Photo	<p>Frontspoiler</p>  <p style="text-align: center;">Photo 1</p>

[Handwritten Signature]

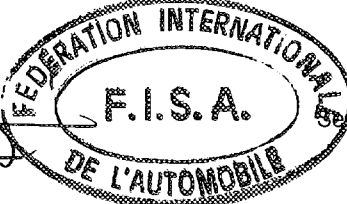

Zeichnungen
Drawings

Seite 14/
page 14

Neue Abmessungen
new dimensions

Motor
Engine

I. Zylinderkopfeinlaßöffnung an der Einlaßkrümmerseite (Abmessungstoleranzen: -2% , $+4\%$)
Cylinder head inlet orifices on manifold side — tolerances on dimensions: -2% , $+4\%$

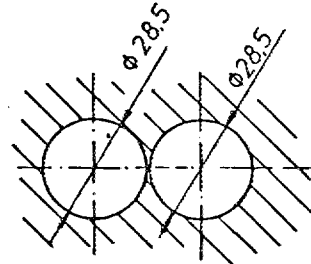
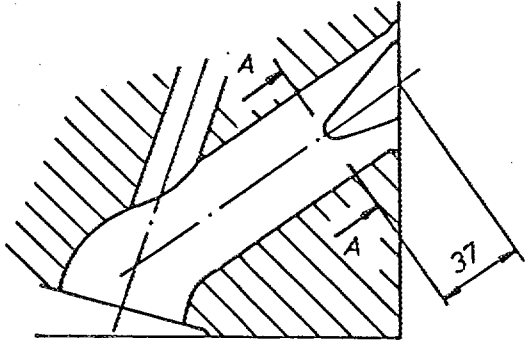

Schnitt A-A

II. Einlaßkrümmeröffnung an der Zylinderkopfseite (Abmessungstoleranzen: -2% , $+4\%$)
Inlet manifold orifices, cylinder head side — tolerances on dimensions: -2% , $+4\%$

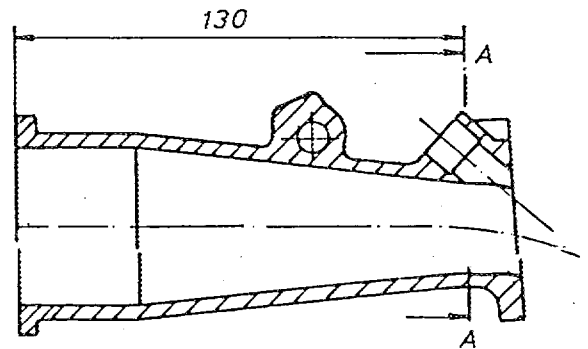
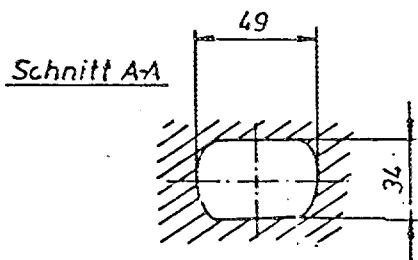

III. Zylinderkopfauslaßöffnung an der Auslaßkrümmerseite (Abmessungstoleranzen: -2% , $+4\%$)
Cylinder head exhaust orifices on manifold side — tolerances on dimensions: -2% , $+4\%$

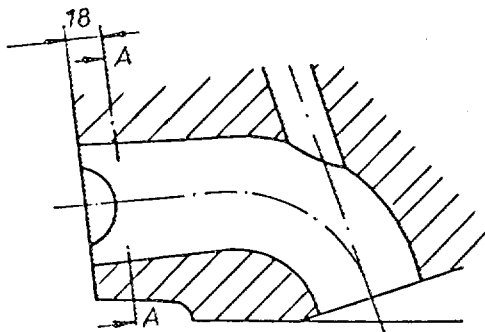

Schnitt A-A

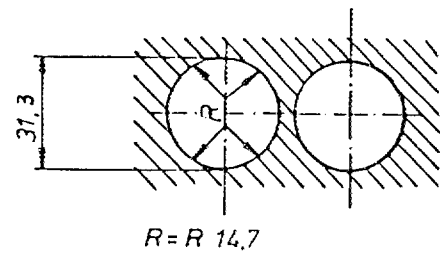

IV. Auslaßkrümmeröffnung an der Zylinderkopfseite (Abmessungstoleranzen: -2% , $+4\%$)
Exhaust manifold orifices, cylinder head side — tolerances on dimensions: -2% , $+4\%$

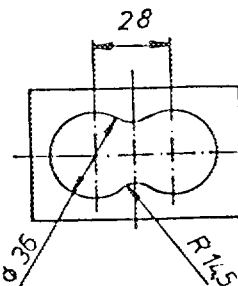
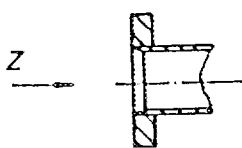

Ansicht Z

FÉDÉRATION INTERNATIONALE DU SPORT AUTOMOBILE

ONS Oberste Nationale Sportkommission für den Automobilsport in Deutschland GmbH

Homologation Nr.

A 5327

Nachtrag Nr.
Extension Nr.

05 / 02 VO

Nachtrag zum offiziellen Testblatt der FISA

Form of extension to the official FISA-Homologation

- ET** Normale Weiterentwicklung des Typs; ab Fahrgestell -Nr.: _____
Normal evolution of the type; as from chassis number
- ES** Sportevolution
Sporting evolution
- VF** Liefervariante
Supply variant
- VO** Ausstattungsvariante
Option variant
- ER** Berichtigung
Erratum

01.07.1987

Homologation gültig ab: _____
Homologation valid as from:

in Gruppe: A
in group

BMW Motorsport GmbH

BMW M3

Hersteller: _____
Manufacturer:

Modell und Typ: _____
Model and type

Seite od. Nachtrag Page or ext.	Artikel Art.	Beschreibung Description	
Seite 7 page 7	701A	verstärkter Vorderachsträger/ reinforced wheel upright front	Photo 1
	701A	verstärkter Vorderachs-Querlenker/ reinforced wishbone front	Photo 2
Seite 8 page 8 (extension 01/01 vo)	803E1	Foto V 1 front zusätzlich/in addition 40/44 mm	

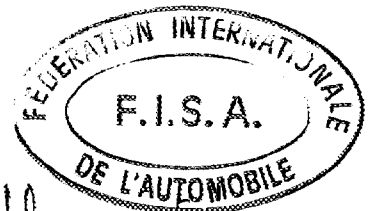

[Handwritten signature]

Marke BMW
Make

Modell BMW M3
Model

Homologations Nr. A 5327
Homologation Nr.

Fotos
Photos

Nachtrag Nr. 05 / 02 V0
Ext. Nr.

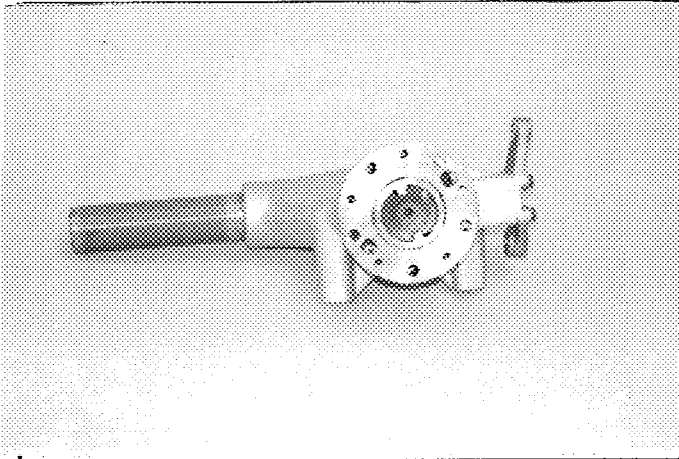

Photo 1

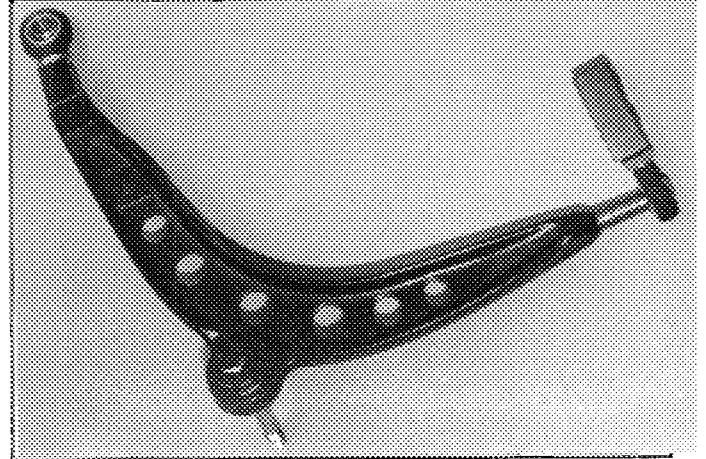
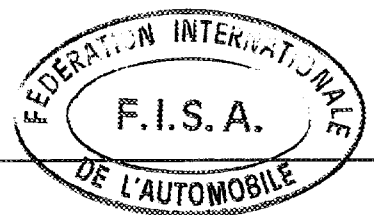
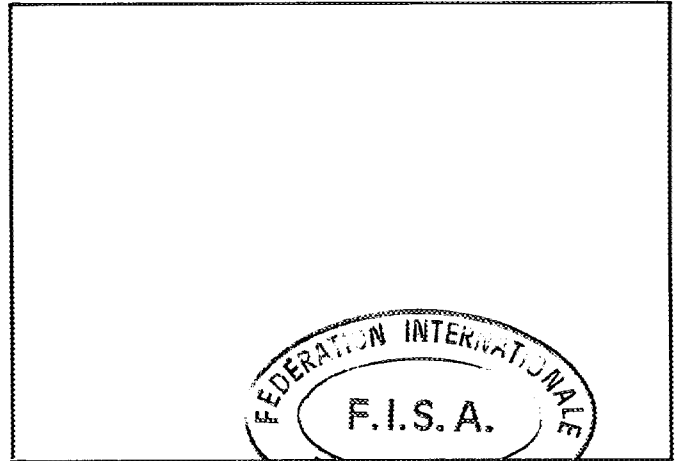
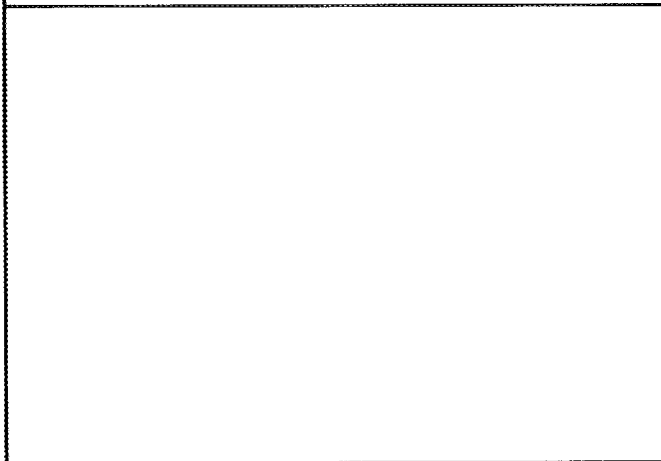
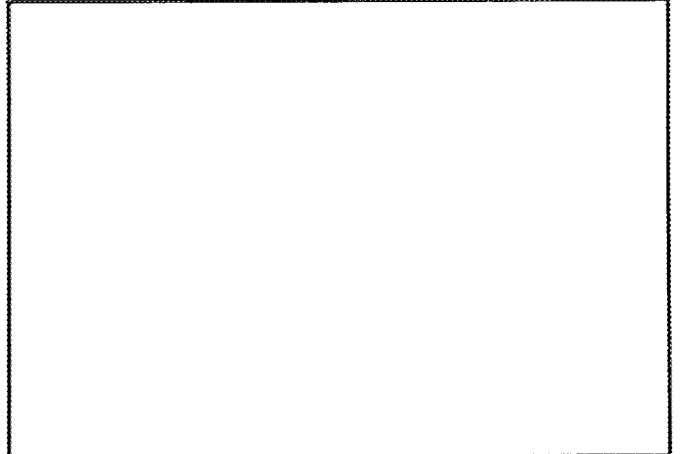
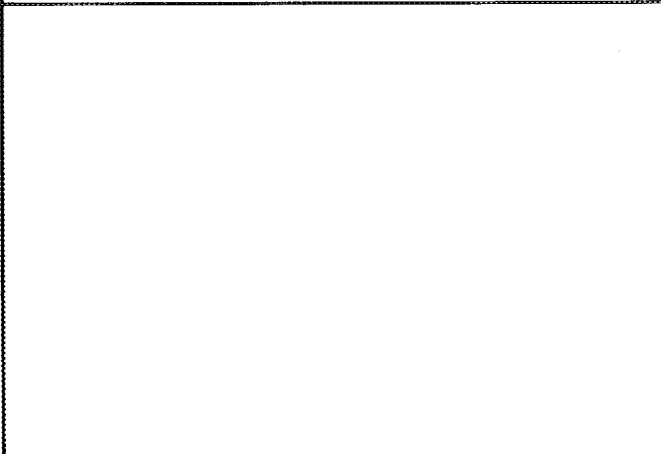

Photo 2



FÉDÉRATION INTERNATIONALE DU SPORT AUTOMOBILE
ONS Oberste Nationale Sportkommission für den Automobilsport in Deutschland GmbH

Homologation Nr.

A 5327

Nachtrag Nr.
Extension Nr.

06 / 03 VO

Nachtrag zum offiziellen Testblatt der FISA

Form of extension to the official FISA-Homologation

- ET** Normale Weiterentwicklung des Typs: ab Fahrgestell-Nr.: _____
Normal evolution of the type, as from chassis number.
- ES** Sportevolution
Sporting evolution
- VF** Liefervariante
Supply variant
- VO** Ausstattungsvariante
Option variant
- ER** Berichtigung
Erratum

Homologation gültig ab: 1.10.87 in Gruppe: A
Homologation valid as from: in group

Hersteller: BMW MOTORSPORT GMBH Modell und Typ: BMW M 3
Manufacturer: Model and type

Seite od. Nachtrag Page or ext.	Artike: Art	Beschreibung Description	
Extension 01/01 VO		zu Foto V1 + V1A zusätzliche Bremsscheibe, Maße unverändert/ additional brake disc, dimensions unchanged	FOTO 1
01/01 VO		zu Foto V3 zusätzlicher Bremsscheibentopf/ additional brake disc mounting bell	FOTO 2+2A
01/01 VO		zu Foto V7 zusätzlicher Bremsscheibentopf/ additional brake disc mounting bell	FOTO 3+3A
01/01 VO		zu Foto V8 Bremssattel: Belaghalterung geändert, Maße unverändert/ brake caliper: pad retaining spring changed, dimensions unchanged	FOTO 4+5
01/01 VO		zu Foto W5 Bremssattel: Belaghalterung geändert, Maße unverändert/ brake caliper: pad retaining spring changed, dimensions unchanged	FOTO 6

[Handwritten Signature]
F.I.S.A.
 SEITE (Page) 1/
 FÉDÉRATION INTERNATIONALE DU SPORT AUTOMOBILE

Marke BMW
Make

Modell M 3
Model

Homologations Nr. A 5327
Homologation Nr.

06 / 03 VO

Nachtrag Nr. _____
Ext. Nr.

Seite od. Nachtrag Page or ext.	Artikel Art.	Beschreibung Description
Extension		
Seite 7	605B 604C	5,44 : 1 49 : 9
	606	Verstärkte Gelenkwelle/ reinforced propeller shaft Material : steel

FOTO 7

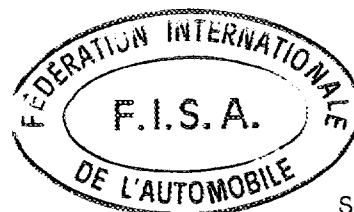

Marke BMW
Make

Modell M 3
Model

Homologations Nr. A 5327
Homologation Nr.

Fotos
Photos

Nachtrag Nr. 06 / 03 V0
Ext. Nr.



FOTO 1



FOTO 2

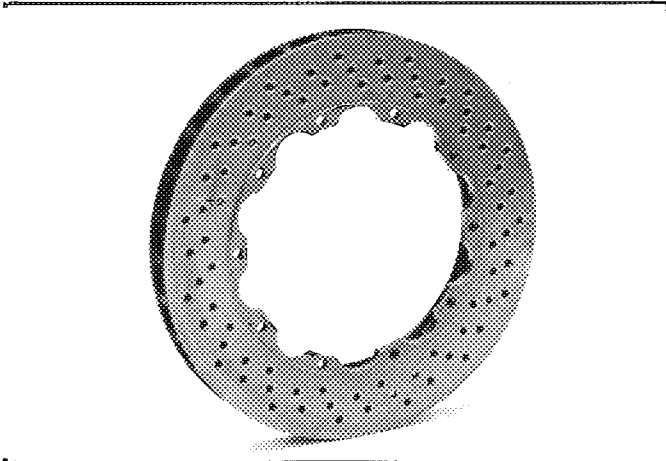

FOTO 2A

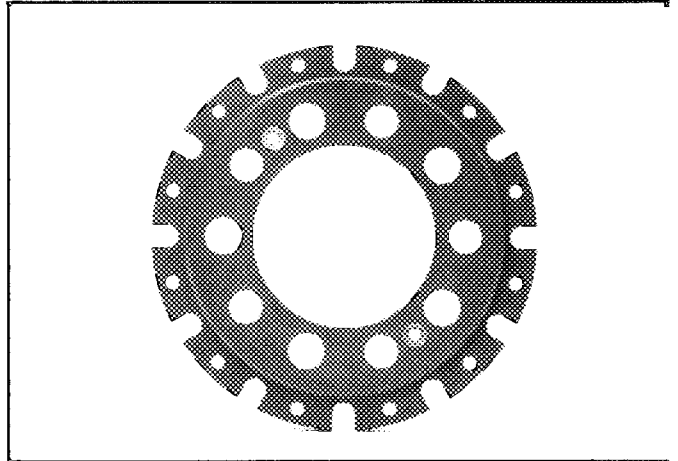

FOTO 3

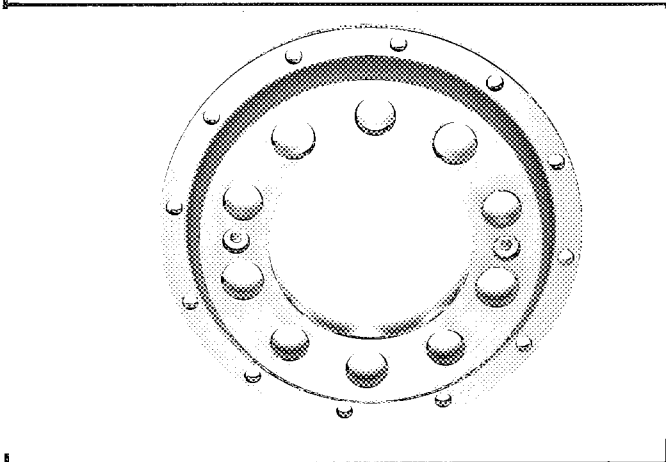

FOTO 3A

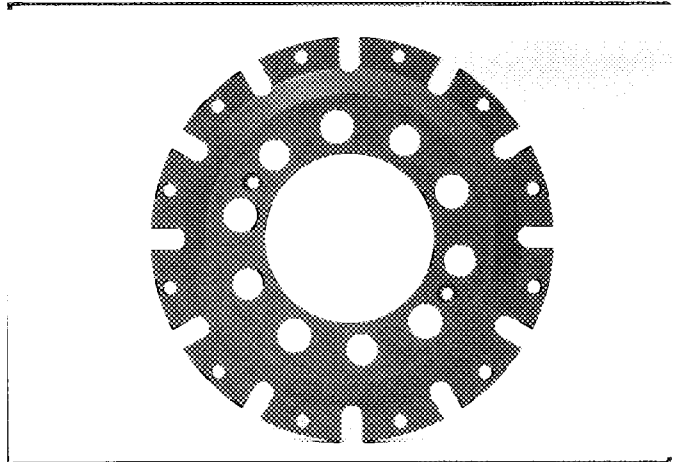

FOTO 4

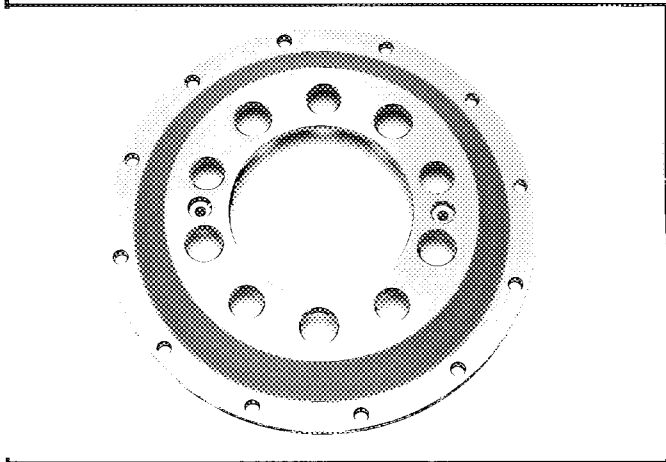

A - 5327

07 / 02 ER

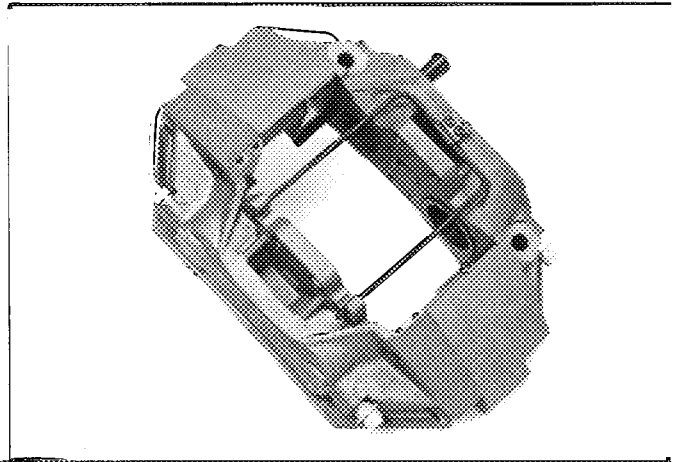
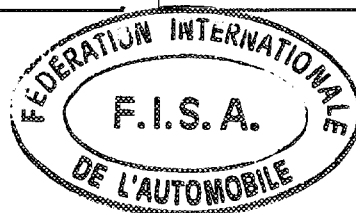
Nachtrag zum offiziellen Testblatt der FISA

Form of extension to the official FISA-Homologation

- ET** Normale Weiterentwicklung des Typs: ab Fahrgestell -Nr.: _____
Normal evolution of the type: as from chassis number:
- ES** Sportevolution
Sporting evolution
- VF** Liefervariante
Supply variant
- VO** Ausstattungsvariante
Option variant
- ER** Berichtigung
Erratum

Homologation gültig ab: 01.10.87 in Gruppe: A
Homologation valid as from in group

Hersteller: BMW Motorsport GmbH Modell und Typ: M 3
Manufacturer Model and type

Seite od. Nachtrag Page or ext.	Artikel Art.	Beschreibung Description
Seite 9 page 9	803 _{G8}	Vorn Front 117 ± 1,5 mm

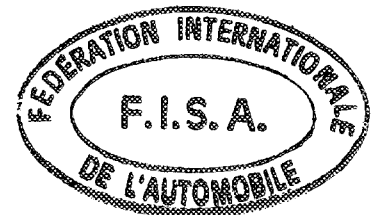

Handwritten signature

Marke BMW
Make

Modell M 3
Model

Homologations Nr. A 5327
Homologation Nr.

06 / 03 VO

Fotos
Photos

Nachtrag Nr. _____
Ext. Nr.



FOTO 5



FOTO 6

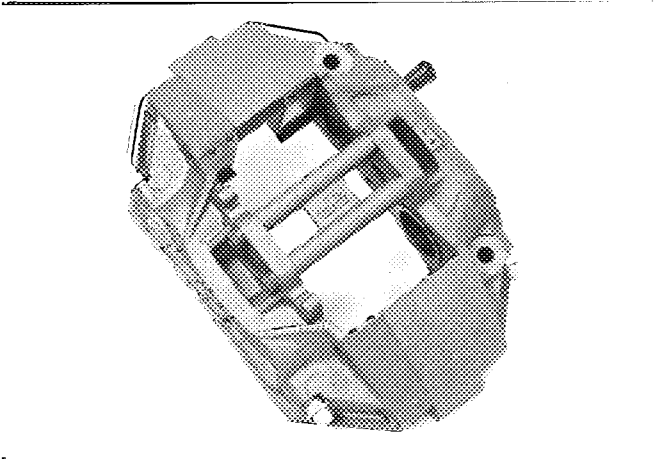

FOTO 7

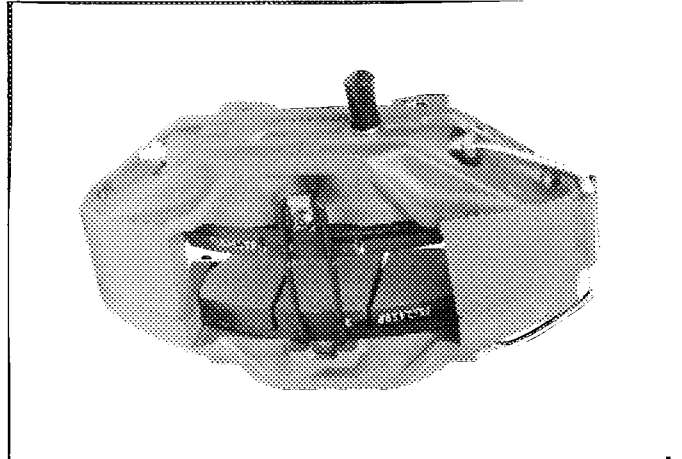

FÉDÉRATION INTERNATIONALE DU SPORT AUTOMOBILE

ONS Oberste Nationale Sportkommission für den Automobilsport in Deutschland GmbH

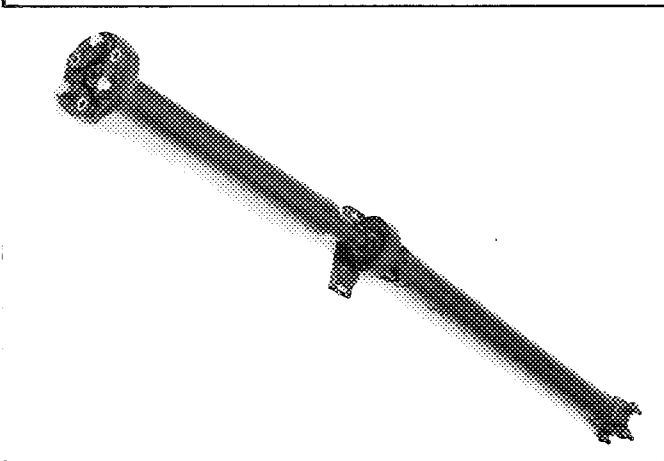
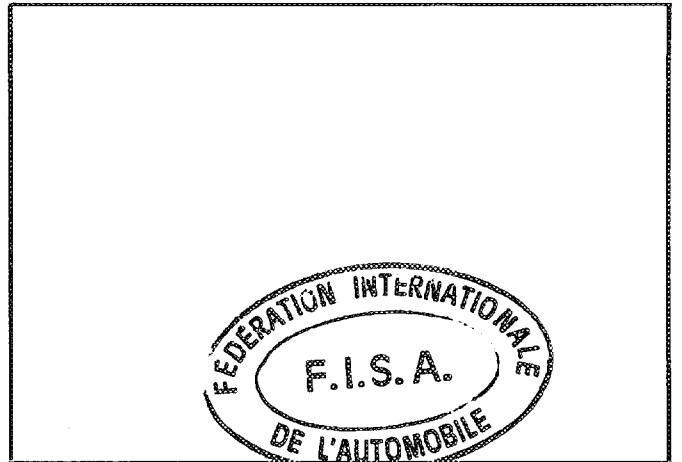
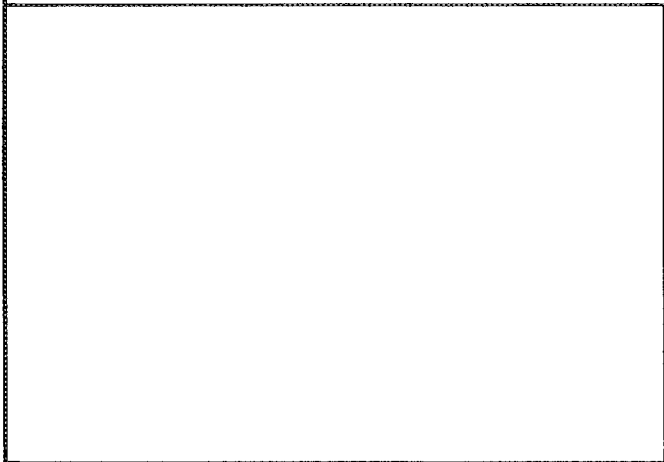
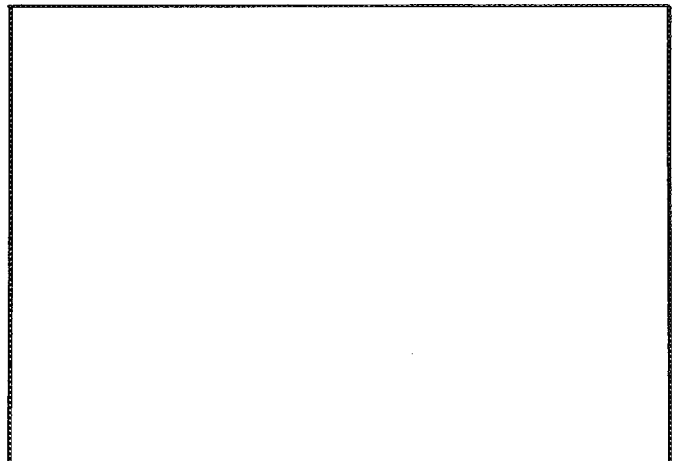
Homologation Nr.

A 5327

Nachtrag Nr.
Extension N°:

08 - 04 VO

Nachtrag zum offiziellen Testblatt der FISA

Form of extension to the official FISA-Homologation:

- ET** Normale Weiterentwicklung des Typs: ab Fahrgestell-Nr.: _____
Normal evolution of the type, as from chassis number:
- ES** Sportevolution
Sporting evolution
- VF** Liefervariante
Supply variant
- VO** Ausstattungsvariante
Option variant
- ER** Berichtigung
Erratum

Homologation gültig ab: _____
Homologation valid as from:

1 FEV. 1988

in Gruppe: A
in group

Hersteller: BMW Motorsport GmbH
Manufacturer:

Modell und Typ: BMW M3
Model and type

Seite od. Nachtrag Page or ext.	Artike: Art.	Beschreibung Description	
Seite 6	603D	Verstärkte Schaltkonsole/ Reinforced Gear Change	Foto 1
Seite 7	605B	4,56:1 - 4,67:1	
	605C	41:9 - 42:9	
	701A	Verstärkter Querlenker, Aluminium/ Reinforced Front Wishbone, Aluminium	Foto 2
	701A	Verstellbarer Rohrstabilisator/ Adjustable Hollow Tube Antirollbar	Foto 3
	701A	Verstärkter Spurstangenhebel, Aluminium/ Reinforced Steering Arm, Aluminium	Foto 4
	701A	Federbeinstützlager, einstellbar/ Top Mounting Plate, adjustable	Foto 5
	701A	Verstärkter Vorderachsradsradträger/ Reinforced Front Wheel Upright	Foto 6

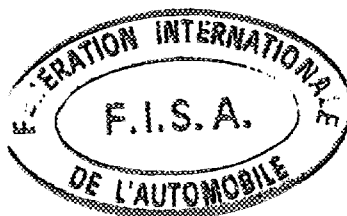

Marke BMW
 Make

Modell M3
 Model

Homologations Nr. A 5327
 Homologation Nr.

Nachtrag Nr. 08 - 04 V0
 Ext. Nr.

Seite od. Nachtrag Page or ext.	Artikel Art.	Beschreibung Description
Seite 8		Bremssattel, vorne/ Brake Caliper, Front Foto 7
	803E1	40 mm + 44 mm
	803G1	2
	803G2	1
	803G3	Aluminium
Seite 8		Bremssattel, hinten/ Brake Caliper, Rear Foto 8
	803E1	34 mm + 38 mm
	803G1	2
	803G2	1
	803G3	Aluminium
Seite 8		Bremsscheibe, hinten/ Brake Disc, Rear Foto 9
	803G4	25,4 mm <u>+</u> 1,0 mm
	803G5	278 mm <u>+</u> 1,5 mm
	803G6	276 mm <u>+</u> 1,5 mm
	803G7	190 mm <u>+</u> 1,5 mm
	803G8	97 mm <u>+</u> 1,5 mm
	803G9	Ja / Yes
	803G10	651,51
Seite 8		Bremsscheibentopf, vorne/ Brake Mounting Foto 10 Bell, Front
		Bremsscheibentopf, hinten/ Brake Mounting Foto 11 Bell, Rear
Seite 8	803	Belüftung Bremsscheibe, vorne/ Foto 12 Front Brake Disc Ventilation
Seite 8	803	Belüftung Bremsscheibe, vorne/ Foto 13 Front Brake Disc Ventilation

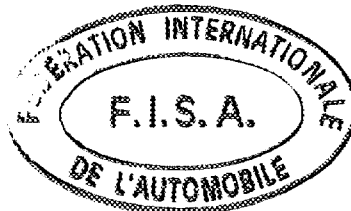

Marke BMW
Make

Modell M3
Model

Homologations Nr. A 5327
Homologation Nr.

Fotos
Photos

Nachtrag Nr. 08 - 04 V0
Ext. Nr.



Foto 1



Foto 2

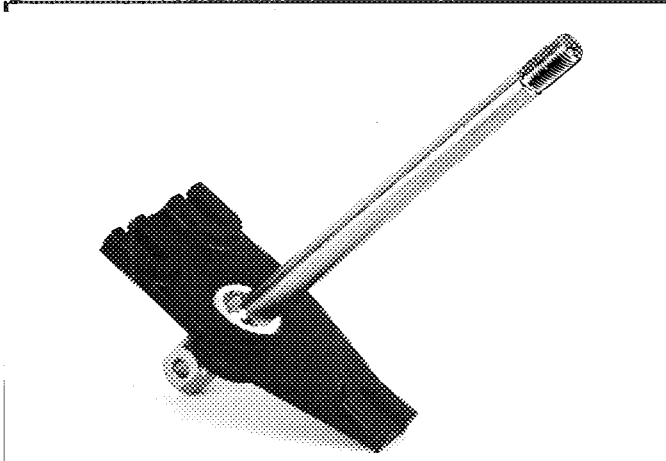

Foto 3

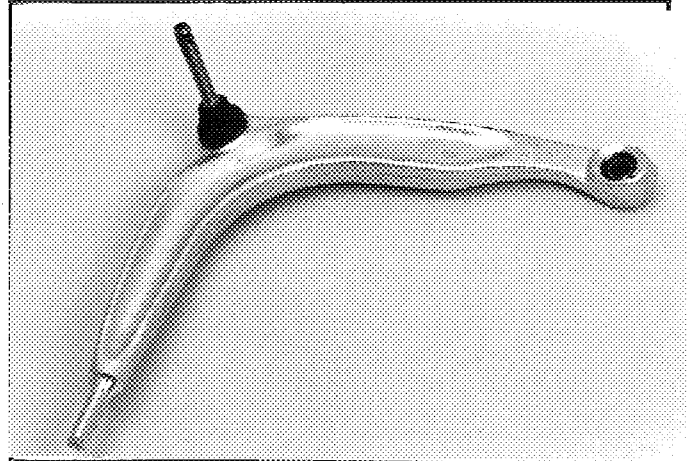

Foto 4

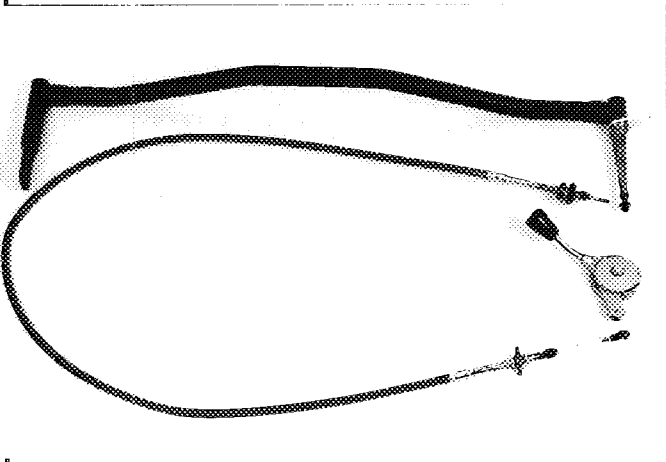

Foto 5

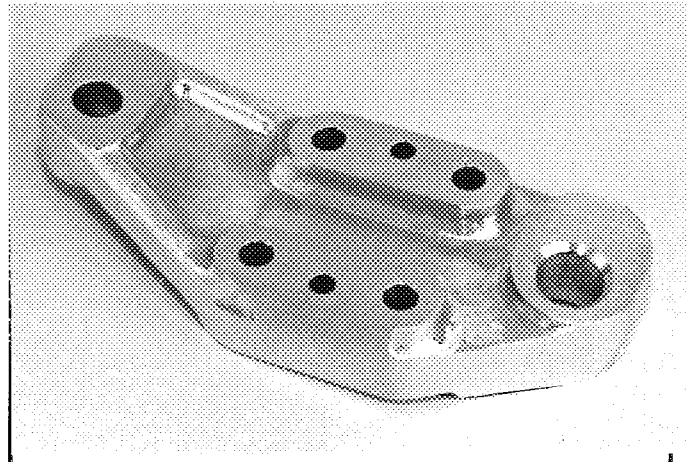

Foto 6

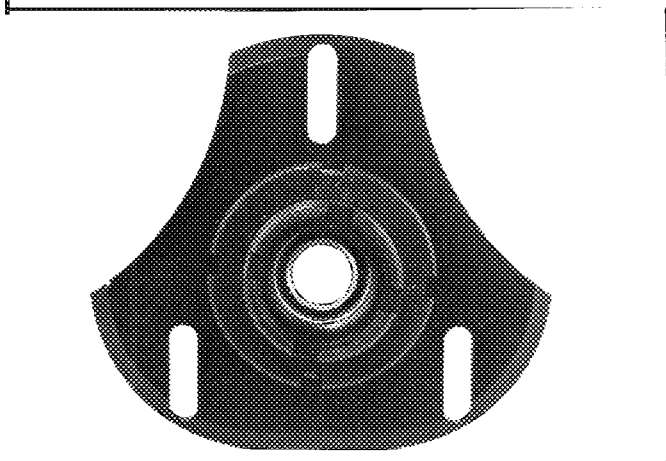

Fotos
Photos

Nachtrag Nr. **08 - 04 VO**
Ext. Nr.

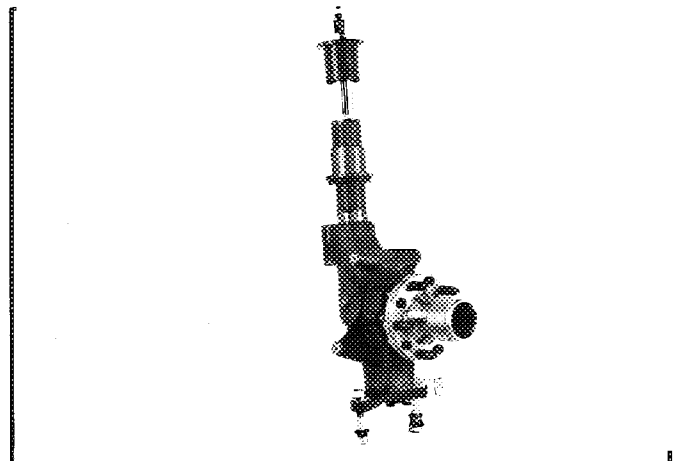
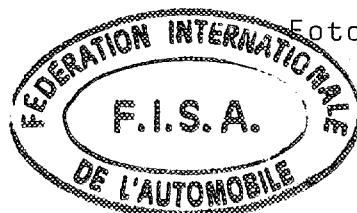

Foto 7



Foto 8

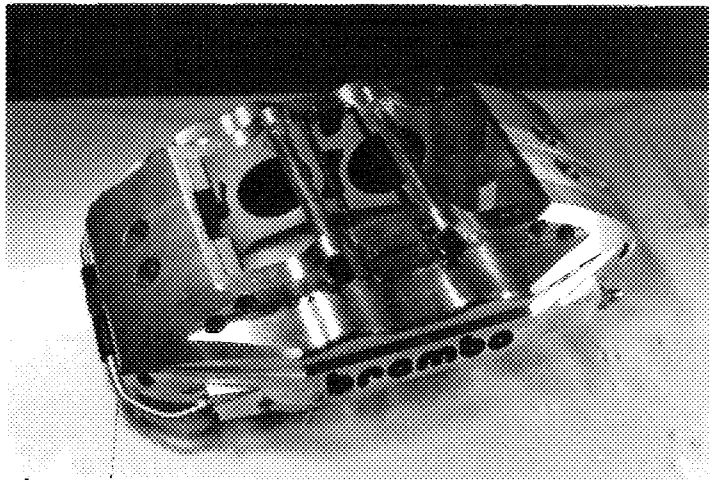

Foto 9

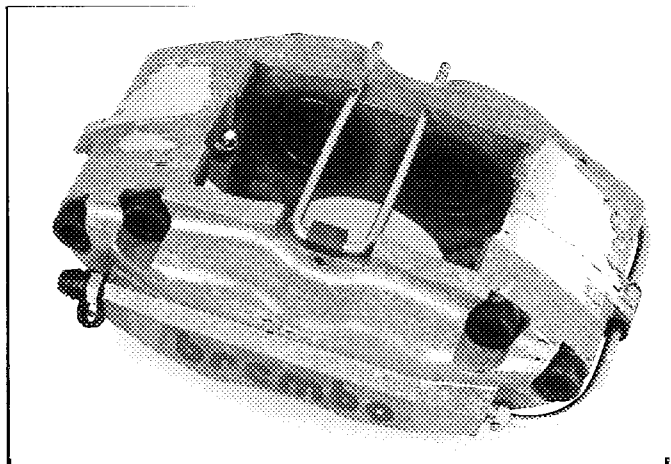

Foto 10

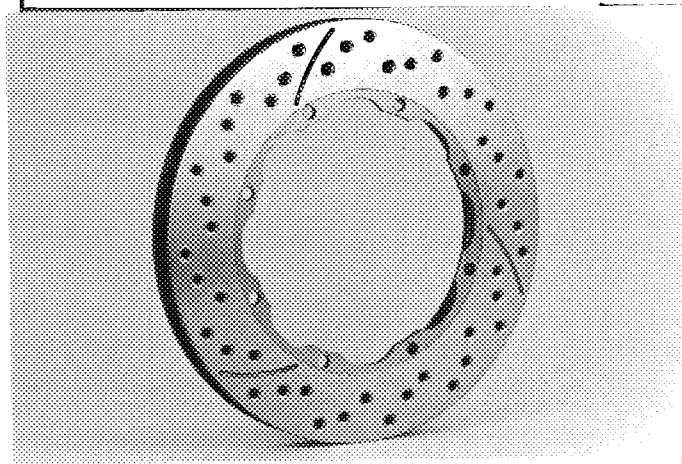

Foto 11

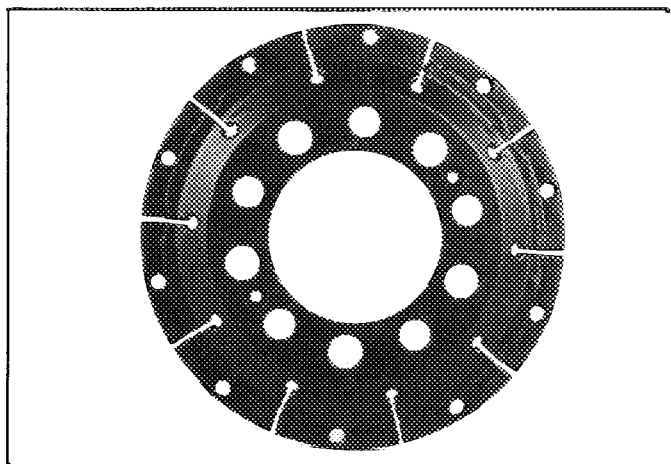

Foto 12

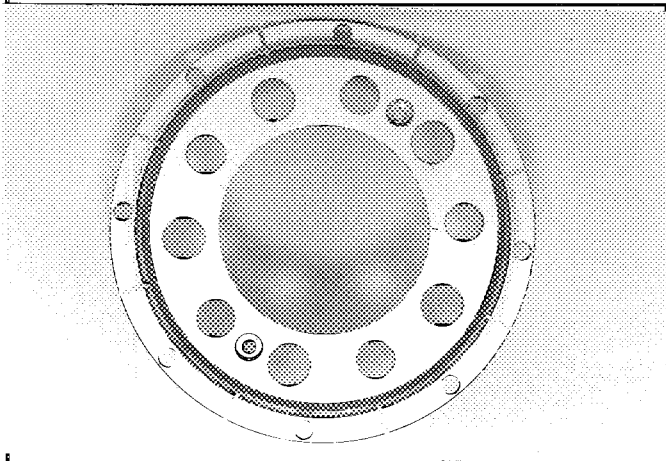

Marke BMW
Make

Modell M3
Model

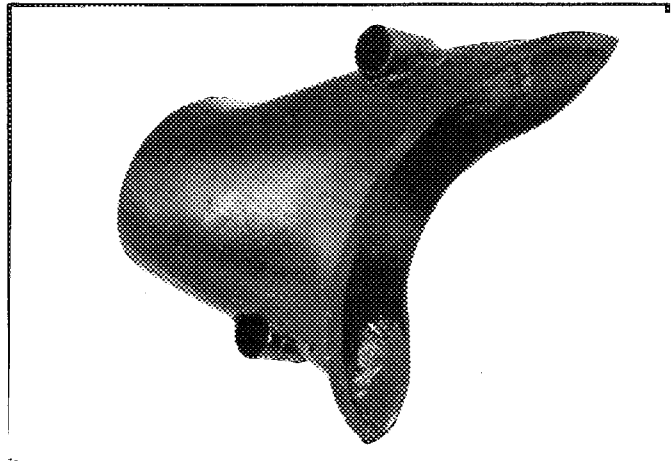
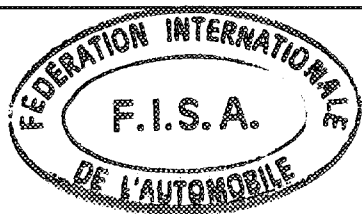
Homologations Nr. A 5327
Homologation Nr.

Fotos
Photos

Nachtrag Nr. 08 - 04 V0
Ext. Nr.



Foto 13



FÉDÉRATION INTERNATIONALE DU SPORT AUTOMOBILE

ONS Oberste Nationale Sportkommission für den Automobilsport in Deutschland GmbH

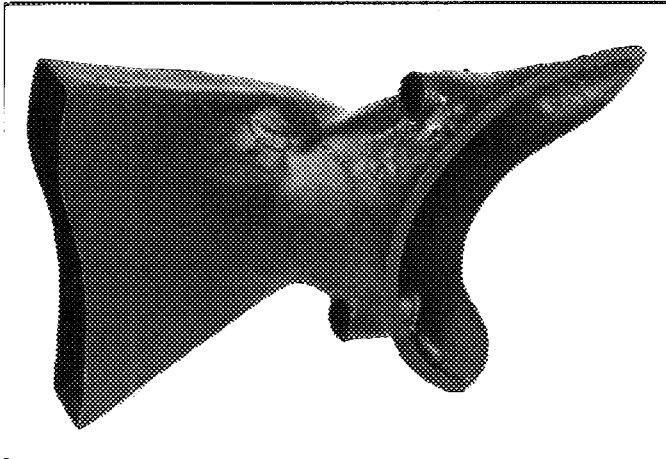
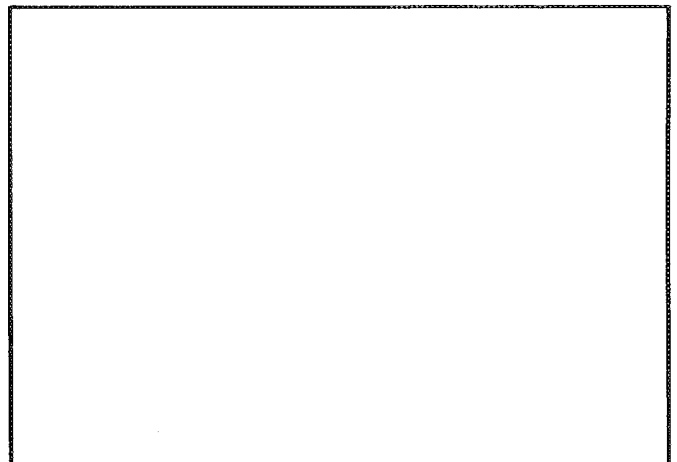
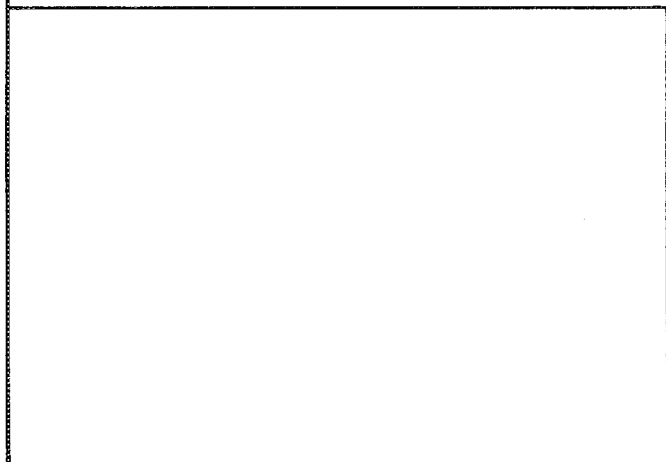
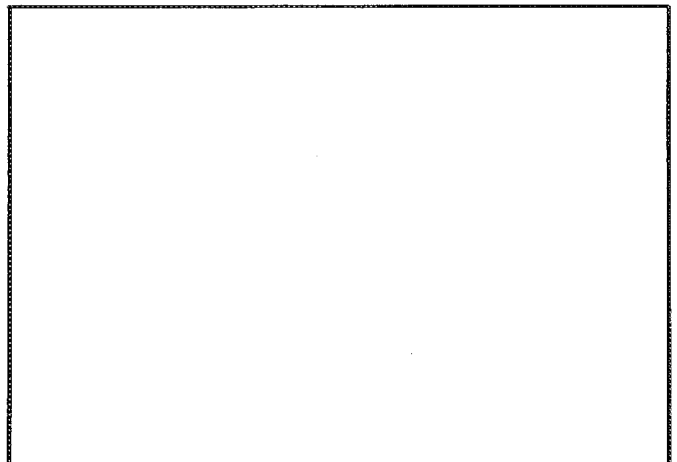
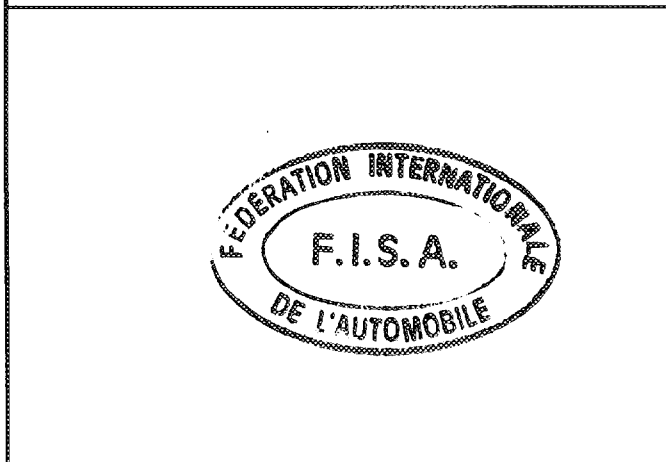
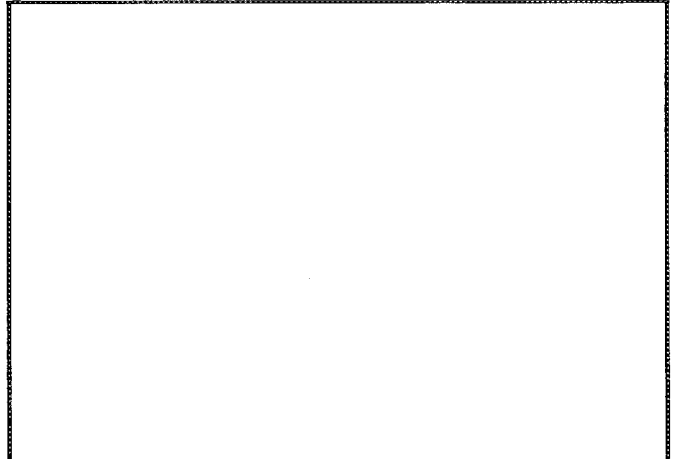
Homologation Nr.

A - 5327

Nachtrag Nr.
Extension Nr.

09 - 05 VO

Nachtrag zum offiziellen Testblatt der FISA

Form of extension to the official FISA-Homologation

- ET** Normale Weiterentwicklung des Typs: ab Fahrgestell-Nr.: _____
Normal: evolution of the type, as from chassis number.
- ES** Sportevolution
Sporting evolution
- VF** Liefervariante
Supply variant
- VO** Ausstattungsvariante
Option variant
- ER** Berichtigung
Erratum

Homologation gültig ab: 1. April 1988 in Gruppe: A
Homologation valid as from: _____ in group: _____

Hersteller: BMW Motorsport GmbH Modell und Typ: BMW M3
Manufacturer: _____ Model and type: _____

Seite od. Nachtrag Page or ext.	Artikel Art.	Beschreibung Description	
Seite 7	605	verstärktes Hinterachsgetriebe / Aluminium reinforced rear diff. / aluminium	Photo 1
	701 A	verstärkter Stabilisator vorn reinforced anti-roll bar front	Photo 2
	701 B	verstärkte Hinterradaufhängung reinforced rear suspension	Photo 4



Signature

Marke BMW
Make

Modell BMW M3
Model

Homologations Nr. A - 5327
Homologation Nr.

Fotos
Photos

Nachtrag Nr. 09 - 05 VO
Ext. Nr.

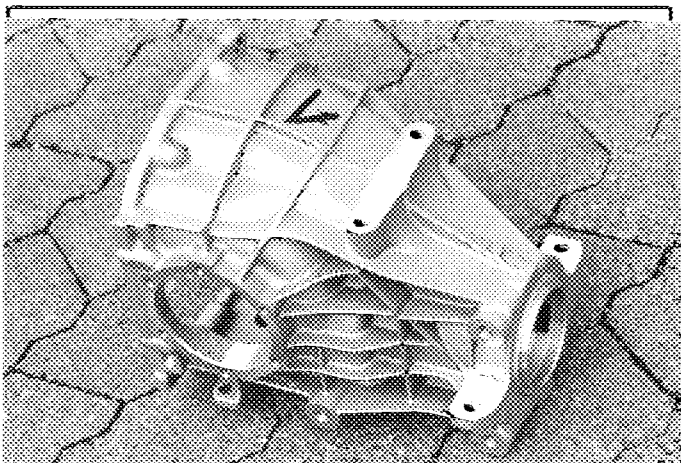

Photo 1

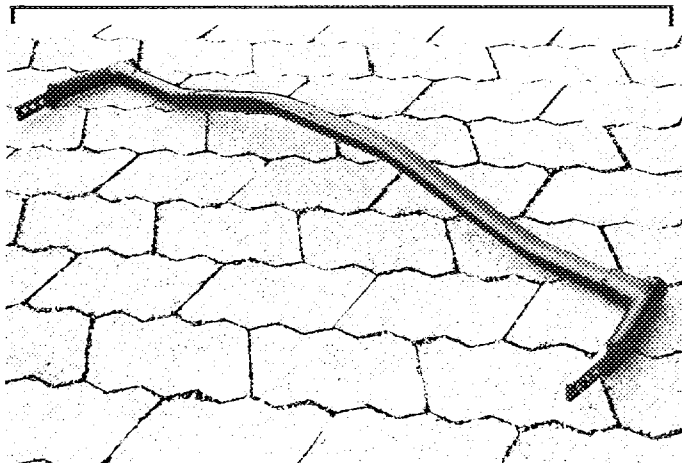

Photo 2

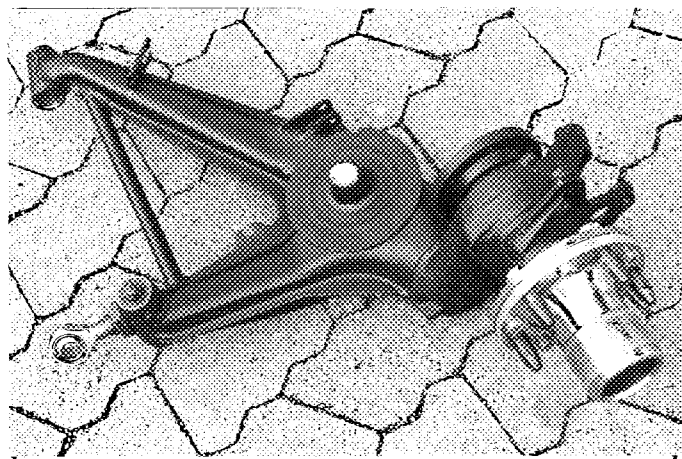
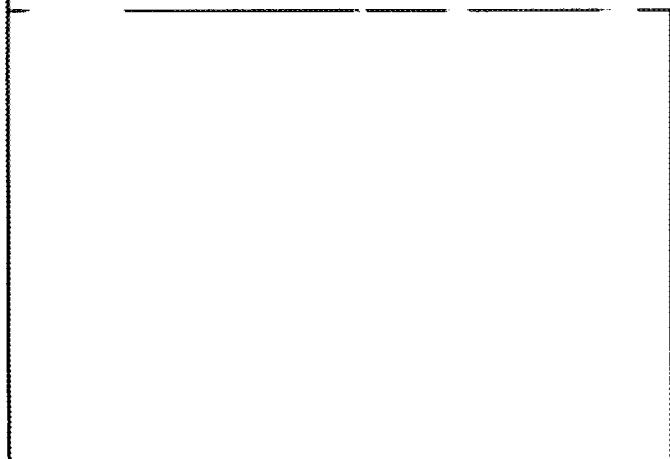
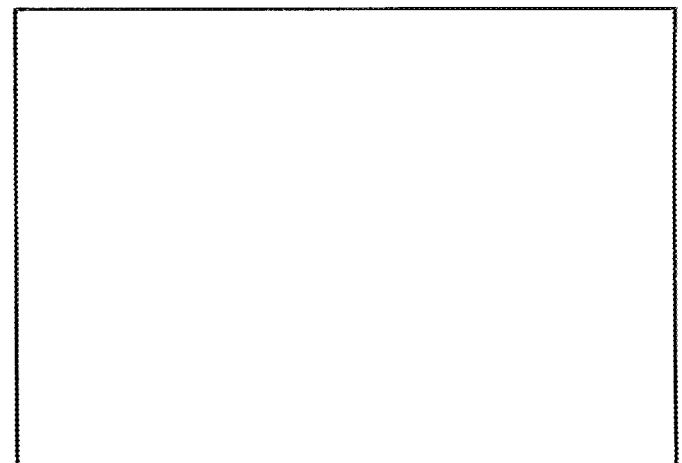

Photo 4



FÉDÉRATION INTERNATIONALE DU SPORT AUTOMOBILE
ONS Oberste Nationale Sportkommission für den Automobilsport in Deutschland GmbH

Homologation Nr.

A - 5327

Nachtrag Nr.
Extension Nr.

10 - 06 VO

Nachtrag zum offiziellen Testblatt der FISA

Form of extension to the official FISA-Homologation

- ET** Normale Weiterentwicklung des Typs: ab Fahrgestell -Nr.: _____
Normal evolution of the type: as from chassis number
- ES** Sportevolution
Sporting evolution
- VF** Liefervariante
Supply variant
- VO** Ausstattungsvariante
Option variant
- ER** Berichtigung
Erratum

Homologation gültig ab: 1. April 1988 in Gruppe: A
Homologation valid as from: _____ in group: _____

Hersteller: BMW Motorsport GmbH Modell und Typ: BMW M3
Manufacturer: _____ Model: and type: _____

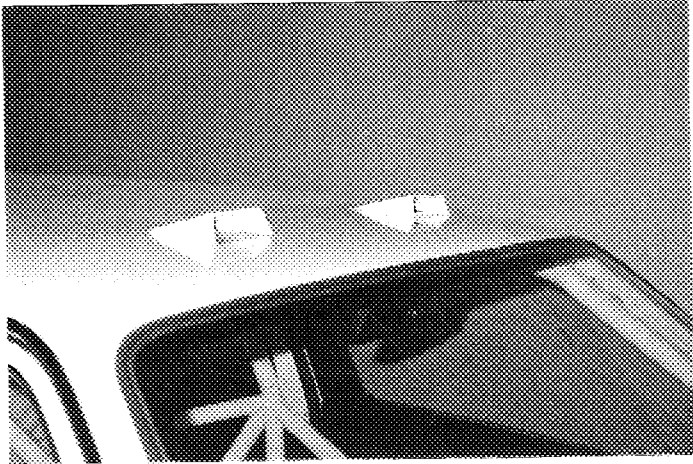
Seite od. Nachtrag Page or ext.	Artikel Art.	Beschreibung Description
Seite 9	901 A	<p>Belüftung Ventilation</p> <p style="text-align: right;">Photo 1</p> <p>FOR RALLIES ONLY</p> 

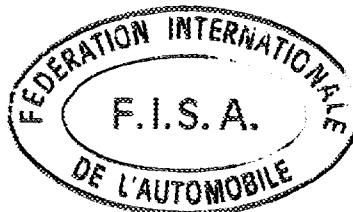

[Handwritten signature]



FEDERATION INTERNATIONALE DU SPORT AUTOMOBILE

Homologation N°

A - 5327

Extension N°

11 - 07 VO

FICHE D'EXTENSION A L'HOMOLOGATION OFFICIELLE FISA
FORM OF EXTENSION TO THE OFFICIAL FISA HOMOLOGATION

- ES** Evolution sportive du type / Sporting evolution of the type
- ET** Evolution normale du type / Normal evolution of the type
- VF** Variante de fourniture / Supply variant
- VO** Variante option / Option variant
- ER** Errata / Erratum

Homologation valable dès le _____ en groupe _____
Homologation valid as from 1. April 1988 in group A

Constructeur _____ Modèle et type _____
Manufacturer BMW Motorsport GmbH Model and type BMW M3

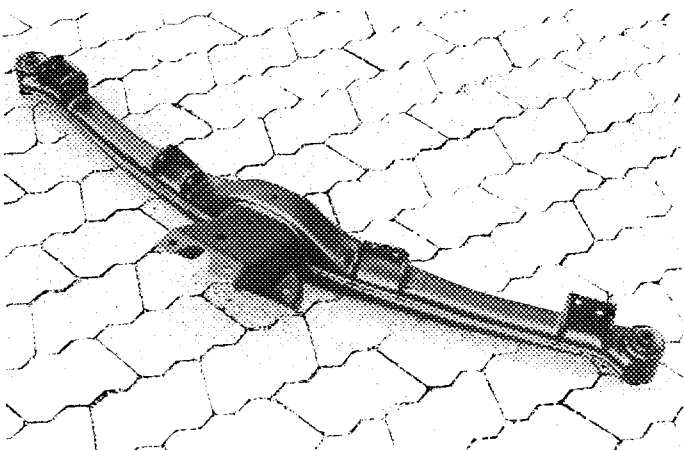
Page ou ext. Page or ext.	Art. Art.	Description Description
Seite 7	701 B	<p>verstärkter Hinterachsträger mit Toleranz von +/- 20 mm für Drehachse, Anlenkpunkte</p> <p>reinforced rear cross member with tolerance of +/- 20 mm for the rotation axis of the semi-trailing arm.</p> <p>Photo</p> 

Signature



FÉDÉRATION INTERNATIONALE DU SPORT AUTOMOBILE

ONS Oberste Nationale Sportkommission für den Automobilsport in Deutschland GmbH

Homologation Nr.

A - 5327

Nachtrag Nr.
Extension Nr.

72 - 0810

Nachtrag zum offiziellen Testblatt der FISA

Form of extension to the official FISA-Homologation

- ET Normale Weiterentwicklung des Typs: ab Fahrgestell -Nr.: _____
Normal evolution of the type: as from chassis number:
- ES Sportevolution
Sporting evolution
- VF Liefervariante
Supply variant
- VO Ausstattungsvariante
Option variant
- ER Berichtigung
Erratum

Homologation gültig ab: 1. Juli 1988 In Gruppe: A
Homologation valid as from: _____ In group: _____

Hersteller: BMW Motorsport GmbH Modell und Typ: BMW M3
Manufacturer: _____ Model and type: _____

Seite od. Nachtrag Page or ext	Artikel Art.	Beschreibung Description
-----------------------------------	-----------------	-----------------------------

6

603

Zusätzliches Getriebe
Additional Gearbox

Photo 1

603e

Zusätzl. Getriebe Additional G.B			
	Über- setzungen ratio	Anzahl der Zähne number of teeth	synchro.
1	2,449	32:15	-
2	1,913	30:18	-
3	1,579	33:24	-
4	1,332	29:25	-
5	1,148	24:24	-
6	1,0	-	-
R	2,449	32:15	-
C	1,148	31:27	-

Art. 603f
Schalt-Schema
Gear change gate

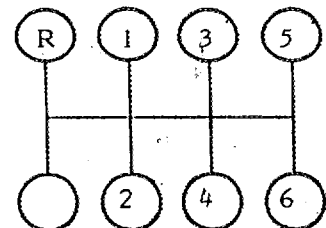

[Handwritten signature]

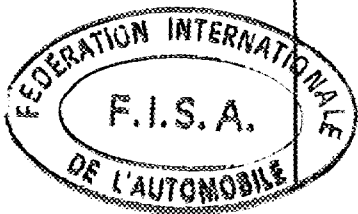

Marke BMW
 Make

Modell M3
 Model

Homologations Nr. A-5327
 Homologation Nr.

Nachtrag Nr. 12 - 0 8 VO
 Ext. Nr.

Seite od. Nachtrag Page or ext.	Artikel Art.	Beschreibung Description	
6	603D	Verstärkte Schaltkonsole Reinforced Gear Change	Photo 2
7	701A	Verstellbarer Stabilisator, hinten Adjustable Antirollbar, rear	Photo 3
	701A	Verstärkter Spurstangenhebel, Aluminium Reinforced Steering Arm, Aluminium	Photo 4
	701A	Verstärkte Vorderradaufhängung Reinforced Front Suspension	Photo 5
	701B	Verstärkte Hinterradaufhängung Reinforced Rear Suspension	Photo 6
9	803	zu Photo VI + VIA Zusätzliche Bremsscheibe, Maße unverändert Additional Brake Disk, dimensions unchanged	Photo 7
	804B	14,6 : 1	
	804C	Nein / No	
	804B	14,4 : 1	
	804C	Ja / Yes	

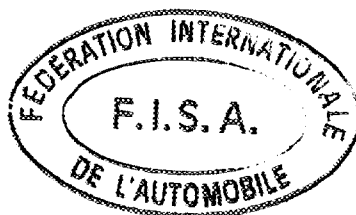

Marke BMW
Make

Modell M3
Model

Homologations Nr. A-5327
Homologation Nr.

Fotos
Photos

Nachtrag Nr. 12-08 VO
Ext. Nr.

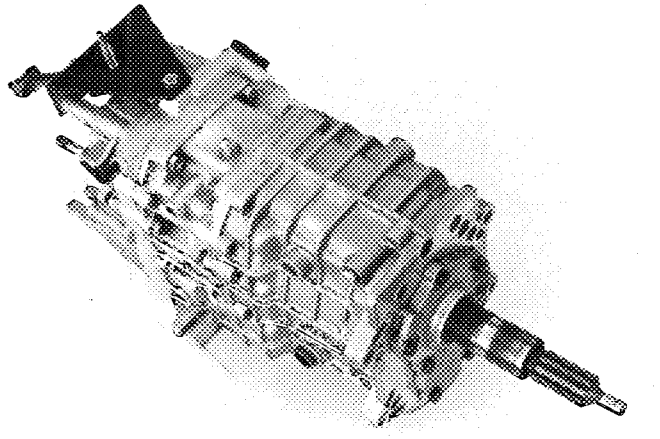

Photo 1

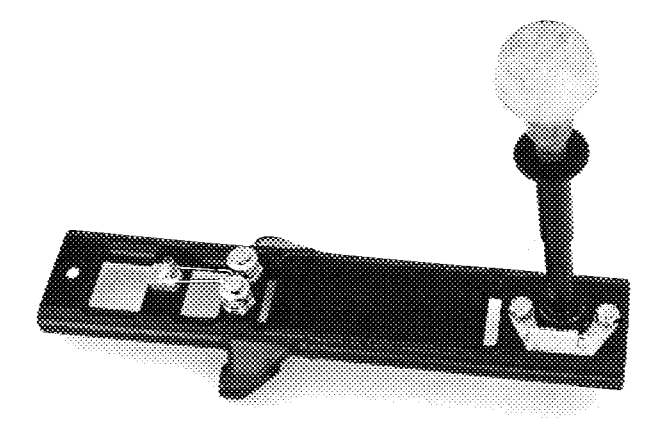

Photo 2

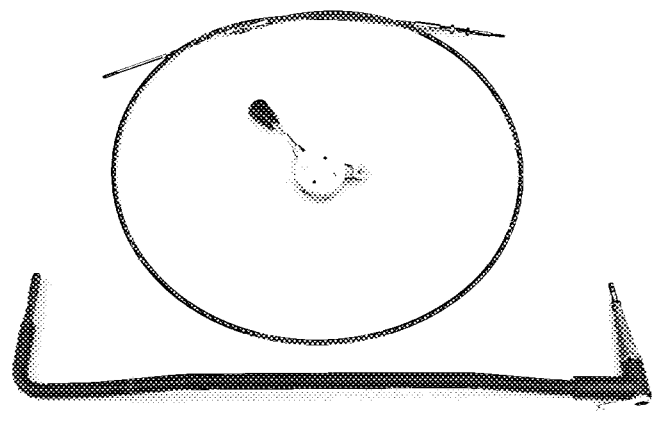

Photo 3



Photo 4

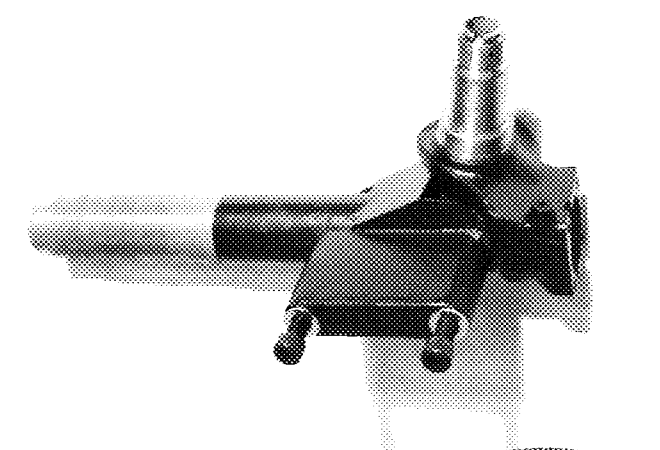

Photo 5

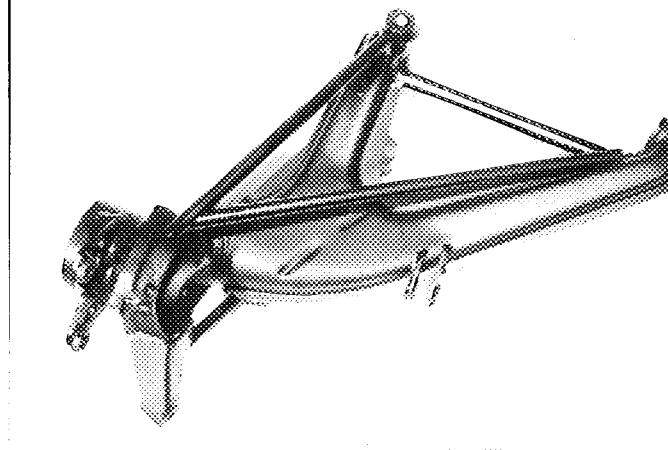

Photo 6



Marke BMW
Make

Modell M3
Model

Homologations Nr. A-5327
Homologation Nr.

Fotos
Photos

Nachtrag Nr. 12-08 VO
Ext. Nr.

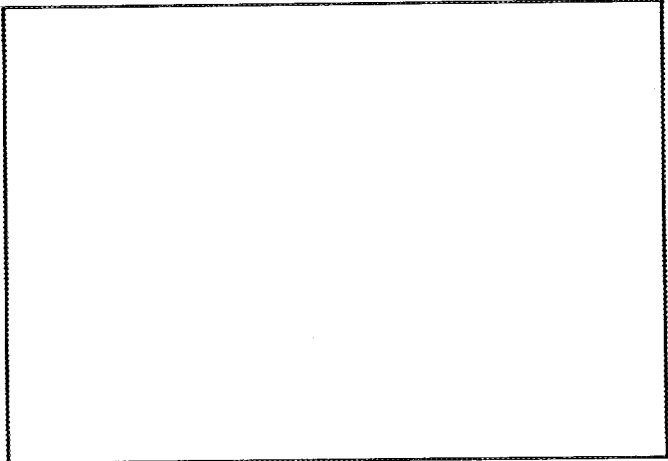
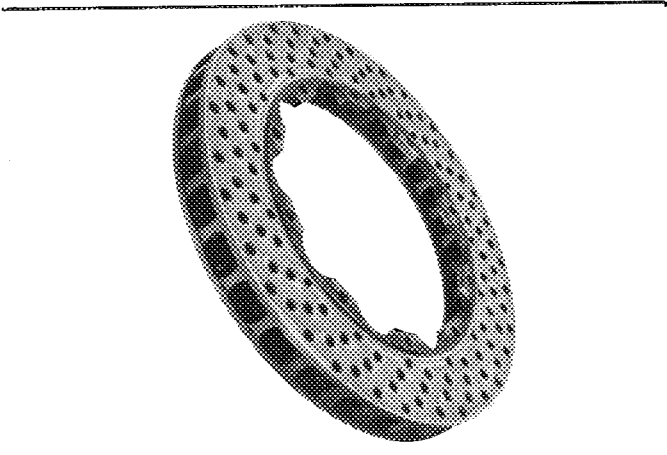
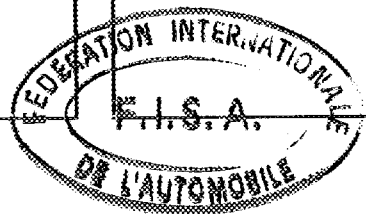
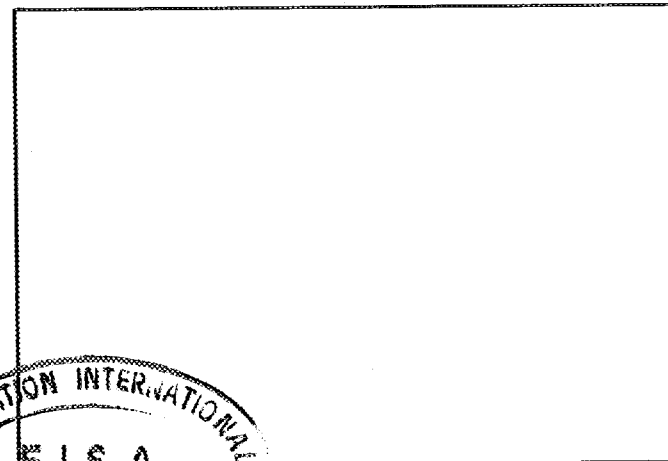
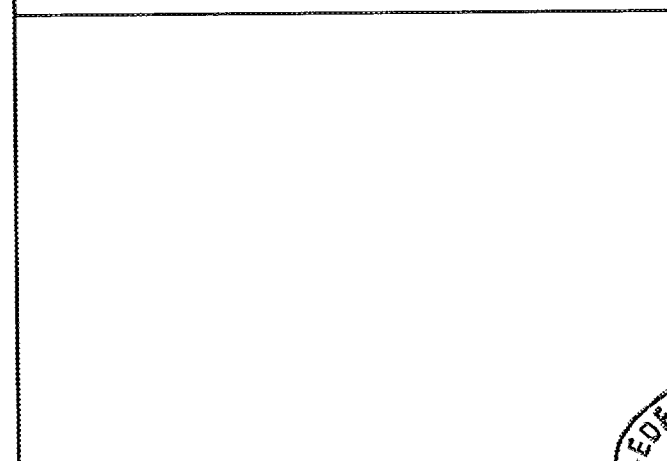
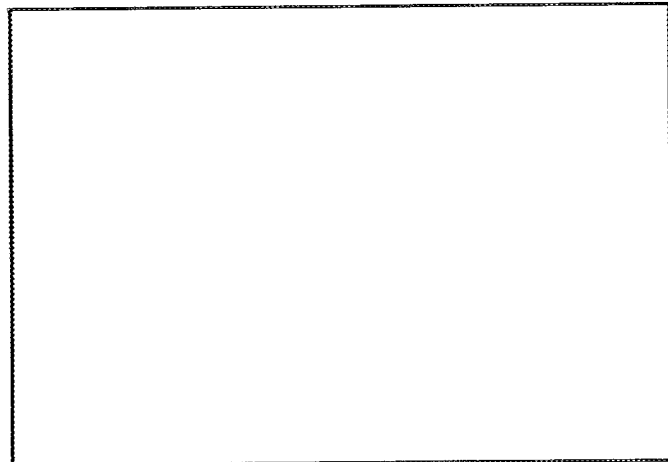
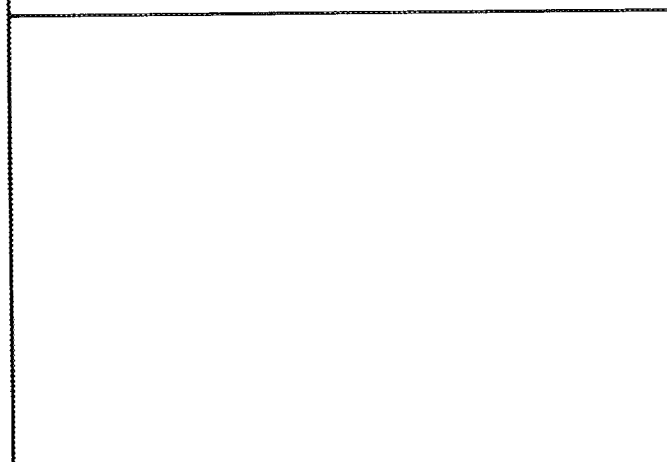

Photo 7





FEDERATION INTERNATIONALE DU SPORT AUTOMOBILE

Homologation N°

A - 5327

Extension N°

13 - 03 ER

FICHE D'EXTENSION A L'HOMOLOGATION OFFICIELLE FISA
FORM OF EXTENSION TO THE OFFICIAL FISA HOMOLOGATION

- ES** Evolution sportive du type / Sporting evolution of the type
- ET** Evolution normale du type / Normal evolution of the type
- VF** Variante de fourniture / Supply variant
- VO** Variante option / Option variant
- ER** Errata / Erratum

Homologation valable dès le _____ en groupe _____
Homologation valid as from 1er Juillet 1988 in group A

Constructeur _____ Modèle et type _____
Manufacturer BMW Motorsport GmbH Model and type M3

Page ou ext. Page or ext.	Art. Art.	Description Description
	701B	THIS ERRATUM CANCELS THE EXTENSION 11/07 VO.

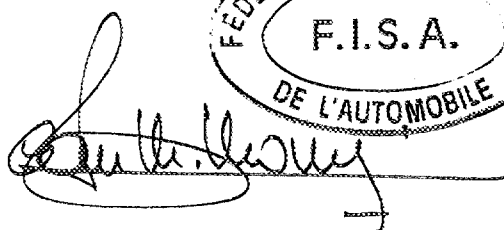
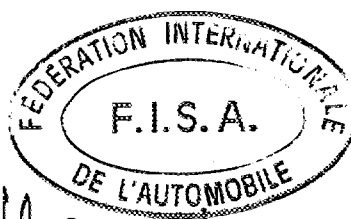
FÉDÉRATION INTERNATIONALE DU SPORT AUTOMOBILE
ONS Oberste Nationale Sportkommission für den Automobilsport in Deutschland GmbH

Homologation Nr.

A - 5327

Nachtrag Nr.
Extension Nr.

14 - 01 ES

Nachtrag zum offiziellen Testblatt der FISA

Form of extension to the official FISA-Homologation

- ET** Normale Weiterentwicklung des Typs; ab Fahrgestell-Nr.: _____
Normal evolution of the type; as from chassis number:
- ES** Sportevolution
Sporting evolution
- VF** Liefervariante
Supply variant:
- VO** Ausstattungsvariante
Option variant:
- ER** Berichtigung
Erratum:

Homologation gültig ab: 1. Juli 1988 in Gruppe: A
Homologation valid as from: _____ in group: _____

Hersteller: BMW Motorsport GmbH Modell und Typ: BMW M3
Manufacturer: _____ Model and type: _____

Seite od. Nachtrag Page or ext.	Artikel Art.	Beschreibung Description
1		Photo A Photo B
7	605b 605c	3,15 : 1 41 : 13
8	801a	Durchmesser Vorn 16"/406 mm Hinten 16"/406 mm Diameter Front Rear
1	902f	erleichteter Heckspoiler mit erhöhter Festigkeit lighter rear spoiler with higher strength



Marke BMW
Make

Modell M3
Model

Homologations Nr. A-5327
Homologation Nr.

Fotos
Photos

Nachtrag Nr. 14 - 01 ES
Ext. Nr.

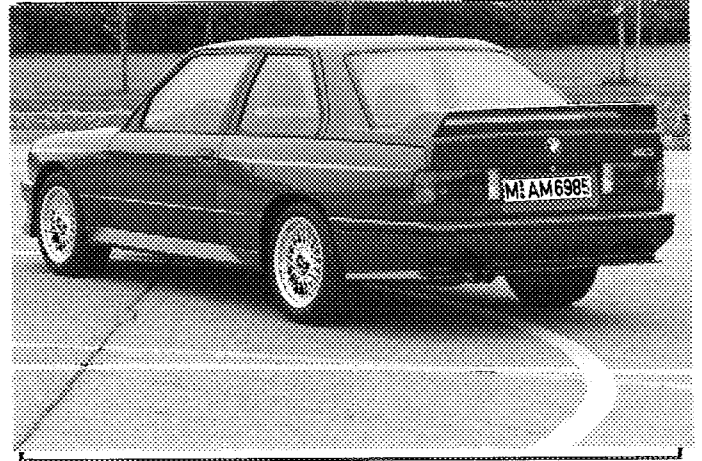
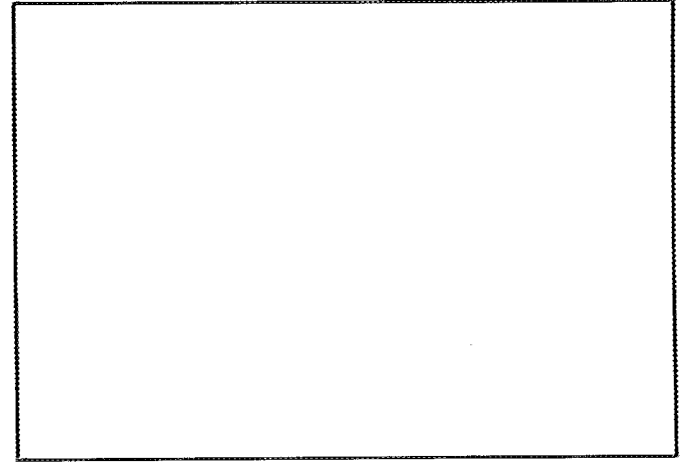
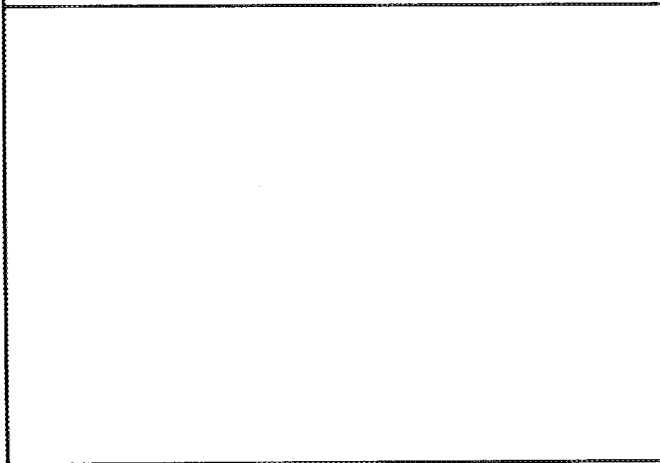
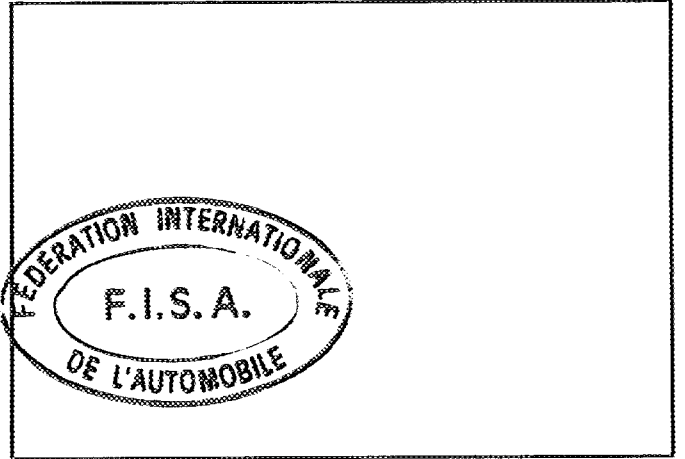
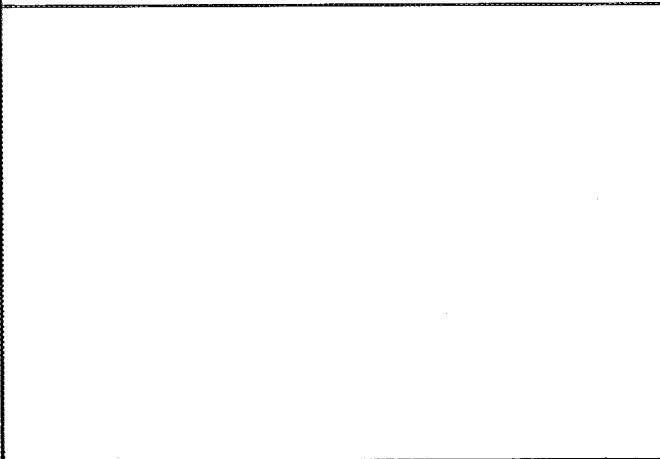

Photo A

Photo B



A-5327

Marke BMW
Make

Modell M 3
Model

Homologation Nr. _____
Homologation Nr.

Nachtrag Nr. 14-01ES
Ext. Nr.

Fotos oder Zeichnungen der Befestigungen an der Karosserie:
Photos or drawings of the attachments on the Body:

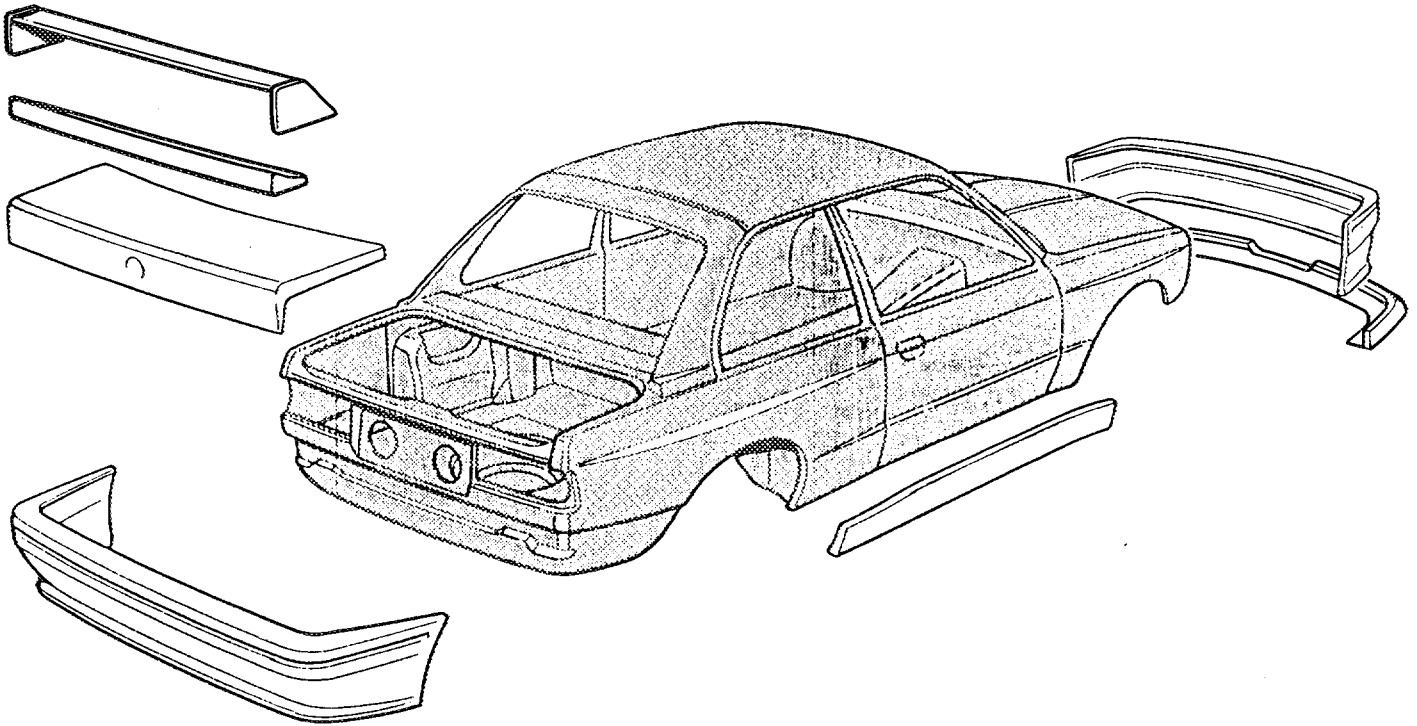

Herausgestellte Karosserieteile aus Kunststoff /
parts put out made out of plastic

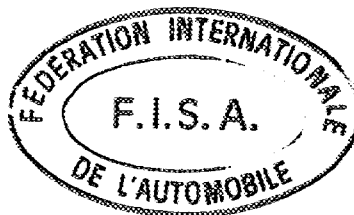

FÉDÉRATION INTERNATIONALE DU SPORT AUTOMOBILE

ONS Oberste Nationale Sportkommission für den Automobilsport in Deutschland GmbH

Homologation Nr.

A - 5327

Nachtrag Nr.
Extension Nr.

15 - 02 VF

Nachtrag zum offiziellen Testblatt der FISA

Form of extension to the official FISA-Homologation

- ET** Normale Weiterentwicklung des Typs: ab Fahrgestell -Nr.: _____
Normal: evolution of the type: as from chassis number
- ES** Sportevolution
Sporting evolution
- VF** Liefervariante
Supply variant
- VO** Ausstattungsvariante
Option variant
- ER** Berichtigung
Erratum

Homologation gültig ab: 1. Juli 1988 in Gruppe: A
Homologation valid as from: _____ in group: _____

Hersteller: BMW Motorsport GmbH Modell und Typ: BMW M3
Manufacturer: _____ Model and type: _____

Seite od. Nachtrag Page or ext.	Artikel Art.	Beschreibung Description
3	320b	Schwungrad, Mindestgewicht mit Anlasserkranz 5120 g Flywheel, Minimum weight with starter ring 5120 g

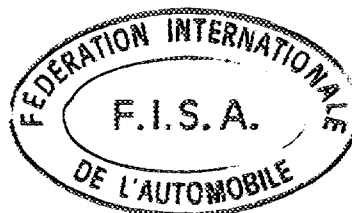

A-5327

16 - 0.3 VF

Nachtrag zum offiziellen Testblatt der FISA

Form of extension to the official FISA-Homologation:

- ET** Normale Weiterentwicklung des Typs: ab Fahrgestell-Nr.: _____
Normal: evolution of the type: as from chassis number:
- ES** Sportevolution
Sporting evolution
- VF** Liefervariante
Supply variant
- VO** Ausstattungsvariante
Option variant
- ER** Berichtigung
Erratum

Homologation gültig ab: 1. Juli 1988 in Gruppe: A
Homologation valid as from: in group

Hersteller: BMW Motorsport GmbH Modell und Typ: M 3
Manufacturer: Model and type

Seite od. Nachtrag <small>Page or ext.</small>	Artikel <small>Art</small>	Beschreibung <small>Description</small>
10	902 l	erleichterte Heckhaube (gleiches Material) lightened rear bonnet (same material)
	902 h	dünneres Sicherheitsglas für Heckscheibe thinner safety glass for the rear window
	902 i	dünneres Sicherheitsglas für Seitenscheiben hinten thinner safety glass for the rear quarter lights
	902 l	erleichterte Stoßfängerträger und Schaum vorn mit höherer Festigkeit (gleiches Material) lightened front bumper mountings and foam with higher strength (same material)
	902 m	erleichterte Stoßfängerträger und Schaum hinten mit erhöhter Festigkeit (gleiches Material) lightened rear bumper mountings and foam with higher strength (same material)

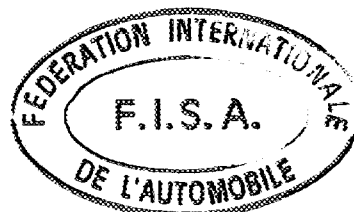



FEDERATION INTERNATIONALE DU SPORT AUTOMOBILE

Homologation N°

A - 5327

Extension N°

17 / 04 ER

FICHE D'EXTENSION A L'HOMOLOGATION OFFICIELLE FISA
FORM OF EXTENSION TO THE OFFICIAL FISA HOMOLOGATION

- ES** Evolution sportive du type / Sporting evolution of the type
- ET** Evolution normale du type / Normal evolution of the type
- VF** Variante de fourniture / Supply variant
- VO** Variante option / Option variant
- ER** Errata / Erratum

Homologation valable dès le _____ en groupe _____
Homologation valid as from 1er Juillet 1988 in group A

Constructeur _____ Modèle et type _____
Manufacturer BMW MOTORSPORT Model and type M3
GMBH

Page ou ext. Page or ext.	Art. Art.	Description Description
14/01 ES 3e page		La page suivante 2/3 remplace la page correspondante. The following page 2/3 replaces the corresponding page.
14/01 ES		Ajouter la page n° 3 /3 suivante Add the following page 3/3

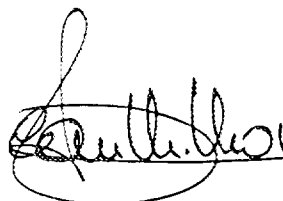
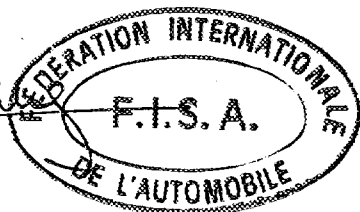
Marko BMW
Make

Modell M 3
Model

Homologation Nr. A-5327
Homologation Nr.

Fotos oder Zeichnungen der Befestigungen an der Karosserie:
Photos or drawings of the attachments on the Body.

Nachtrag Nr. 17/04 FR
Ext. Nr.

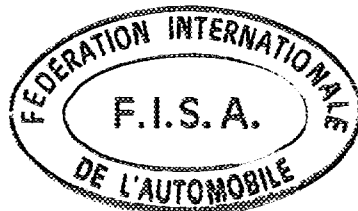
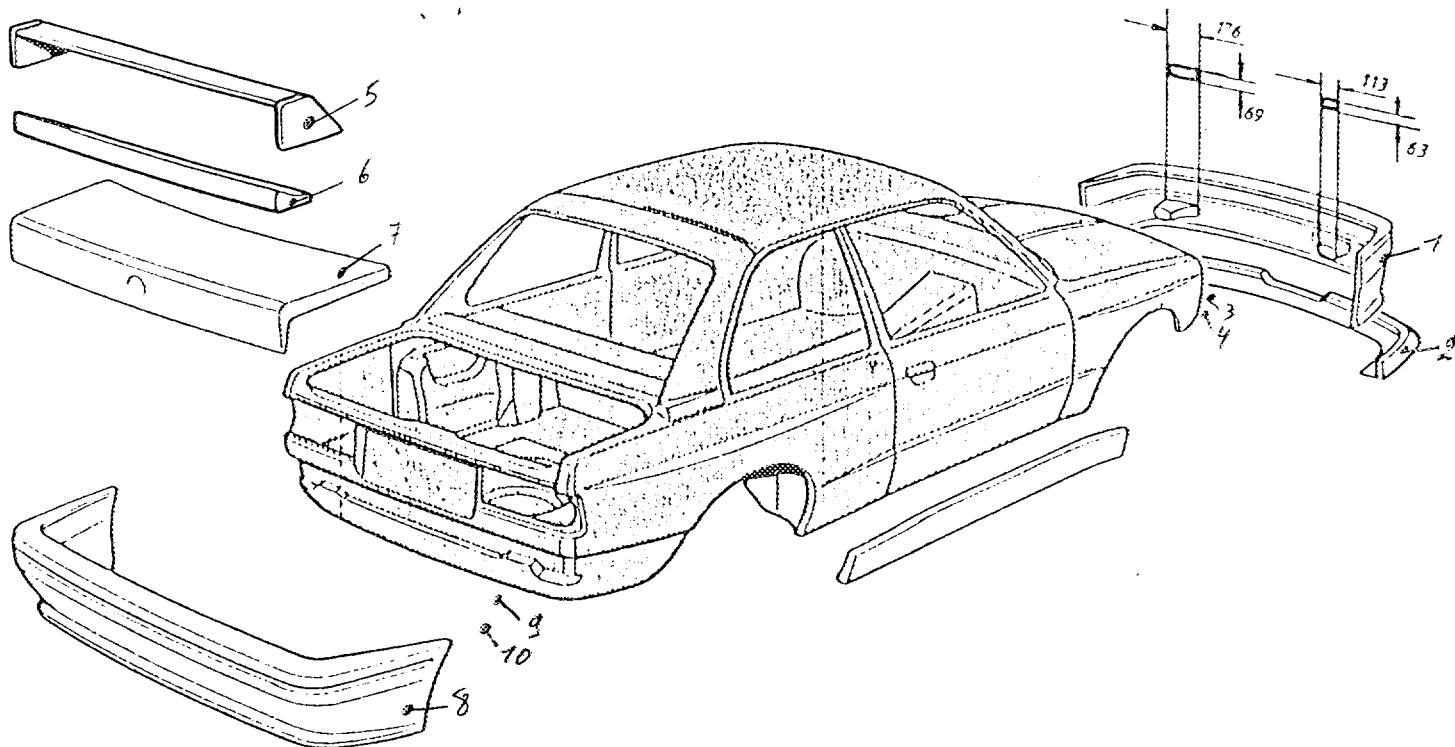

Herausgestellte Karosserieteile aus Kunststoff /
parts put out made out of plastic

- | | |
|-----------------------------------------|--------------------------------------------------------------------------------------|
| 1. Pare-choc AV. enveloppe | matière: polyurethane |
| 2. Spoiler AV. additionnel | matière: polyurethane
poids : 2,070 Kg. |
| 3. Renfort support de
pare-choc AV. | matière: mousse de polypropylène
poids : 0,135 Kg./pièce |
| 4 Support de pare-choc AV. | matière: Thermoplastique renforcé
de matre en fibre de verre
poids : 3,150 Kg. |
| 5. Aile ARR. | matière: polyurethane renforcé
de fibre de carbone
poids : 4,140 Kg. |
| 6. Spoiler ARR. | matière: polyurethane
poids : 1,530 Kg. |
| 7. Capot ARR. | matière: polyester renforcé de fibres
poids : 8,730 Kg. |
| 8. Pare-choc ARR. enveloppe | matière: polyurethane |
| 9. Renfort support de
pare-choc ARR. | matière: mousse de polypropylène
poids : 0,1125 Kg./pièce |
| 10. Support de pare-choc ARR. | matière: Thermoplastique renforcé
de matre en fibre de verre
poids : 3,375 Kg. |

Marke BMW
 Make

Modell M3
 Model:

Homologations Nr. A - 5327
 Homologation Nr.

Nachtrag Nr. 17 / 04 ER
 Ext. Nr.

Seite od. Nachtrag Page or ext.	Artikel Art.	Beschreibung Description	Minimalgewicht/ Minimum weight
10			
	902 l	erleichterte Heckhaube (gleiches Material) lightened rear bonnet (same material)	8,730 kg
	902 h	dünnere Sicherheitsglas (3mm) für Heckscheibe thinner safety glass (3mm) for the rear window	5,400 kg
	902 i	dünnere Sicherheitsglas (3 mm) für Seitenscheiben hinten thinner safety glass (3 mm) for the rear quarter lights	1,900 kg
	902 l	erleichterte Stoßfängerträger und Schaum vorn mit höherer Festigkeit (gleiches Material) lightened front bumper mountings and foam with higher strength (same material)	3,420 kg
	902 m	erleichterte Stoßfängerträger und Schaum hinten mit erhöhter Festigkeit (gleiches Material) lightened rear bumper mountings and foam with higher strength (same material)	3,600 kg

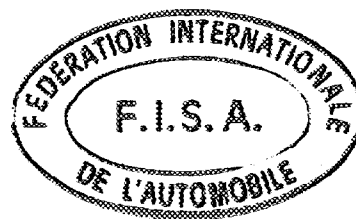



FEDERATION INTERNATIONALE DU SPORT AUTOMOBILE

Homologation N°

A - 5327

Extension N°

18 / 05 ER

FICHE D'EXTENSION A L'HOMOLOGATION OFFICIELLE FISA
FORM OF EXTENSION TO THE OFFICIAL FISA HOMOLOGATION

- ES** Evolution sportive du type / Sporting evolution of the type
- ET** Evolution normale du type / Normal evolution of the type
- VF** Variante de fourniture / Supply variant
- VO** Variante option / Option variant
- ER** Errata / Erratum

Homologation valable dès le 1er Juillet 1988 en groupe A
Homologation valid as from _____ in group _____

Constructeur BMW MOTORSPORT Modèle et type M3
Manufacturer GMBH Model and type _____

Page ou ext. Page or ext.	Art. Art.	Description Description
15/02 VF	320b	Le poids de 5120 g est corrigé en 5160 g The weight of 5120 g is changed in 5160 g.
16/03 VF		Cette extension est annulée. This extension is cancelled.

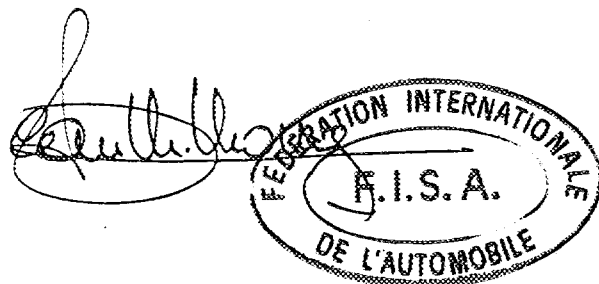

FÉDÉRATION INTERNATIONALE DU SPORT AUTOMOBILE

ONS Oberste Nationale Sportkommission für den Automobilsport in Deutschland GmbH

Homologation Nr.

A-5327

Nachtrag Nr.
Extension Nr.

19 - 06 ER

Nachtrag zum offiziellen Testblatt der FISA

Form of extension to the official FISA-Homologation

- ET** Normale Weiterentwicklung des Typs; ab Fahrgestell-Nr.: _____
Normal evolution of the type as from chassis number:
- ES** Sportevolution
Sporting evolution
- VF** Liefervariante
Supply variant
- VO** Ausstattungsvariante
Option variant
- ER** Berichtigung
Erratum

Homologation gültig ab: 01 SEP. 1988 in Gruppe: A
Homologation valid as from: in group

Hersteller: BMW Motorsport GmbH Modell und Typ: BMW M3
Manufacturer: Model and type

Seite od. Nachtrag Page or ext.	Artikel Art.	Beschreibung Description
		Erratum für folgende Artikel im Nachtrag 01/01 VO Erratum for following articles in extension 01/01 VO
Seite 9 page 9	803E1	Foto V6 + V7 2 x 38,1 / 2 x 41,3
	803E1	Foto W5 + W6 + W3a 2 x 38,1 / 2 x 41,3 or 4 x 36,0 or 4 x 31,75
	803E1	Foto V8 2 x 41,3 / 2 x 44,45

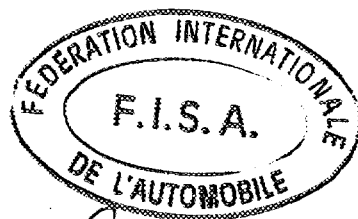

[Handwritten signature]

FÉDÉRATION INTERNATIONALE DU SPORT AUTOMOBILE

ONS Oberste Nationale Sportkommission für den Automobilsport in Deutschland GmbH

Homologation Nr.

A-5327

Nachtrag Nr.
Extension Nr.

20 / 09 VO

Nachtrag zum offiziellen Testblatt der FISA

Form of extension to the official FISA-Homologation

- ET** Normale Weiterentwicklung des Typs: ab Fahrgestell-Nr.: _____
Normal evolution of the type, as from chassis number
- ES** Sportevolution
Sporting evolution
- VF** Liefervariante
Supply variant
- VO** Ausstattungsvariante
Option variant
- ER** Berichtigung
Erratum

01 OCT. 1988

Homologation gültig ab: _____ in Gruppe: A
Homologation valid as from: _____ in group

Hersteller: BMW Motorsport GmbH Modell und Typ: BMW M3
Manufacture: _____ Model and type

Seite od. Nachtrag Page or ext.	Artikel Art	Beschreibung Description
------------------------------------	----------------	-----------------------------

Seite 7

701 B

verstärkte Anlenkpunkte mit Toleranz von +/- 20 mm für Drehachse, Schräglenker

reinforced mounting points with tolerance of +/- 20 mm for the rotation axis of the semi-trailing arm

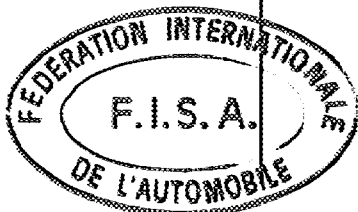
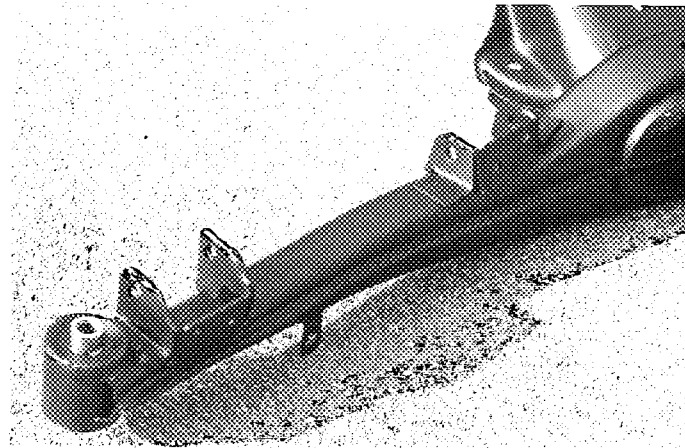

Signature



FEDERATION INTERNATIONALE DU SPORT AUTOMOBILE

Homologation N°

A - 5327

Extension N°

21 / 07 ER

FICHE D'EXTENSION A L'HOMOLOGATION OFFICIELLE FISA
FORM OF EXTENSION TO THE OFFICIAL FISA HOMOLOGATION

- ES** Evolution sportive du type / Sporting evolution of the type
- ET** Evolution normale du type / Normal evolution of the type
- VF** Variante de fourniture / Supply variant
- VO** Variante option / Option variant
- ER** Errata / Erratum

Homologation valable dès le _____ en groupe _____
Homologation valid as from 1er Octobre 1988 in group A

Constructeur _____ Modèle et type _____
Manufacturer BMW MOTORSPORT GMBH Model and type M3

Page ou ext. Page or ext.	Art. Art.	Description Description
------------------------------	--------------	----------------------------

Cet erratum annule et remplace l'erratum 17/04 ER.

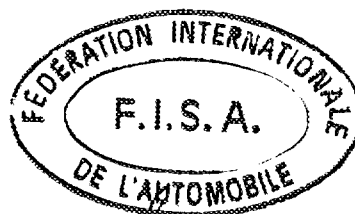

[Signature]

Marke
Marka

BMW

Modell
Model

M 3

A - 5327

Homologation Nr.
Homologation No.

Fotos oder Zeichnungen der Befestigungen an der Karosserie:
Photos or drawings of the attachments on the body.

Nachtrag Nr.
Ext. No.

21 / 07 ER

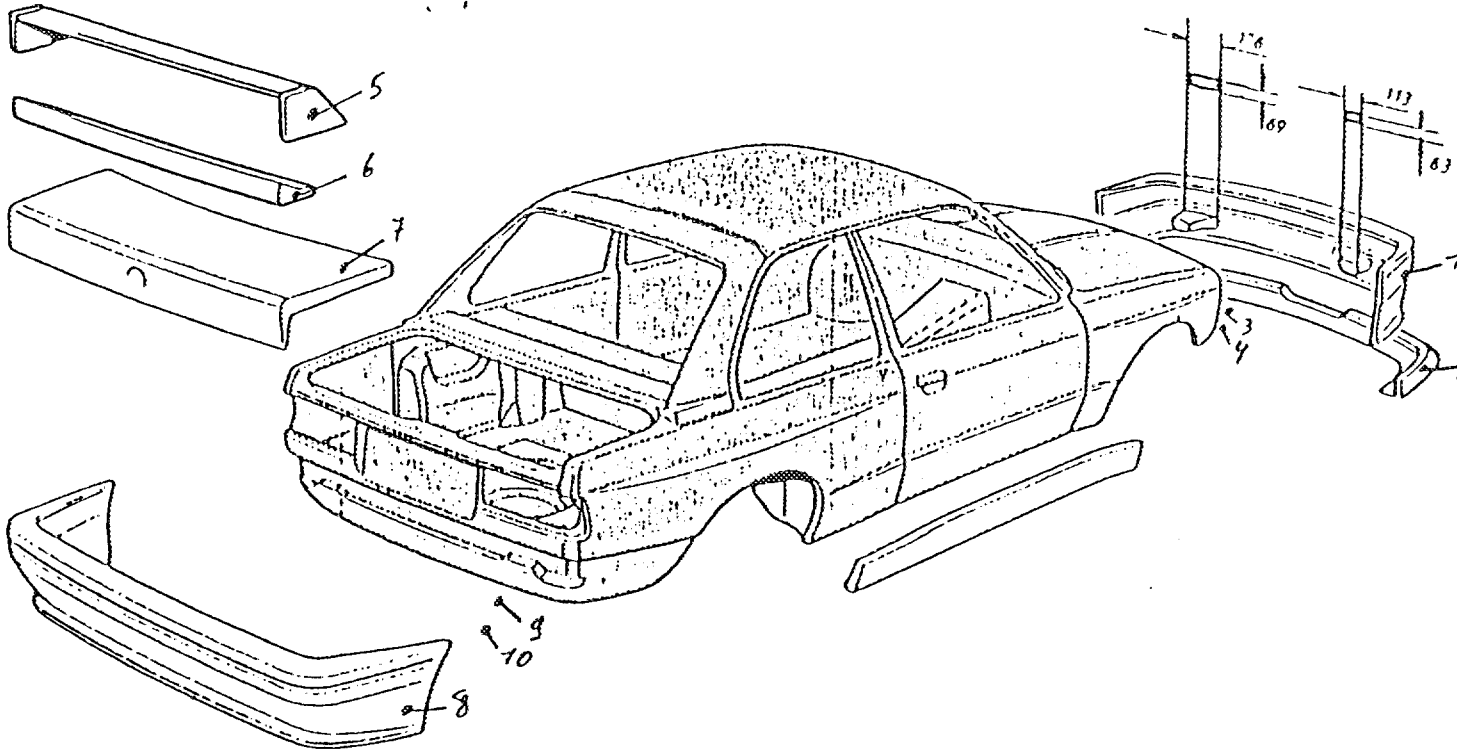

Herausgestellte Karosserieteile aus Kunststoff /
parts put out made out of plastic

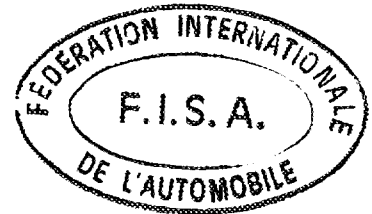

- | | |
|--------------------------------------------------------------------|--------------------------------------------------------------------------------------------------------------------------|
| 1. Vorderer Stoßfänger / Front bumper | Material: Polyurethanschaum mit Glasfaser
material: Polyurethane foam with fiberglass |
| 2. Zusatzfrontspoiler / Additional front spoiler | Material: Polyurethanschaum mit Glasfaser
material: Polyurethane foam with fiberglass
Gewicht/weight: 2,070 kg |
| 3. Schaum (Stoßfängerträger vorn)/
Foam (front bumper mounting) | Material/material: Elastopolypropylen
Gewicht/weight: 0,135 kg |
| 4. Stoßfängerträger vorn/
Front bumper mounting | Material: Glasfaserverstärkter Thermoplast
material: fiberglass-reinforced thermoplastic
Gewicht/weight: 3,150 kg |
| 5. Heckflügel / Rear wing | Material: Polyurethanschaum mit Kohlefaser
material: Polyurethane foam with carbonfiber
Gewicht/weight: 4,140 kg |
| 6. Zusatzheckspoiler / Additional rear spoiler | Material: Polyurethanschaum mit Stahleinlage
material: Polyurethane foam with steel inlet
Gewicht/weight: 1,530 kg |

Marke BMW
Make

Modell M 3
Model

Homologation Nr. A-5327
Homologation Nr.

Nachtrag Nr. 21 / 07 ER
Ext. Nr.

7. Heckhaube / Rear bonnet

Material: Polyester mit Glasfaser
material: Polyester with fiberglass
Gewicht/weight: 8,730 kg

8. Hinterer Stoßfänger / Rear bumper

Material: Polyurethanschaum mit Glasfaser
material: Polyurethane foam with fiberglass

9. Schaum (Stoßfängerträger hinten)/
Foam (rear bumper mounting)

Material/material: Elastopolypropylen
Gewicht/weight: 0,1125 kg

10. Stoßfängerträger hinten/
Rear bumper mounting

Material: Glasfaserverstärkter Thermoplast
material: fiberglass-reinforced thermoplastic
Gewicht/weight: 3,375 kg

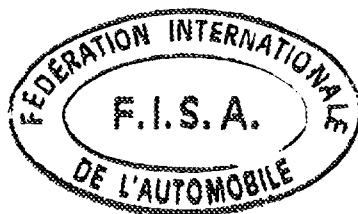

A-5327

22 / 10 VO

Nachtrag zum offiziellen Testblatt der FISA

Form of extension to the official FISA-Homologation

- ET** Normale Weiterentwicklung des Typs: ab Fahrgestell-Nr.: _____
Normal evolution of the type, as from chassis number.
- ES** Sportevolution
Sporting evolution
- VF** Liefervariante
Supply variant
- VO** Ausstattungsvariante
Option variant
- ER** Berichtigung
Erratum

Homologation gültig ab: 1. Januar 1989 in Gruppe: A
Homologation valid as from in group

Hersteller: BMW Motorsport GmbH Modell und Typ: BMW M3
Manufacturer Model and type

Seite od. Nachtrag Page or ext.	Artikel Art.	Beschreibung Description	
7	701A	Verstärkte Vorderradaufhängung Reinforced Front Suspension	Photo 1
	701A	Verstärkter vorderer Querlenker Reinforced Front Wishbone	Photo 2

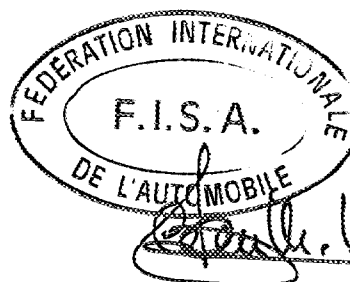

Marke BMW
Make

Modell M3
Model

Homologations Nr. A-5327
Homologation Nr.

Fotos
Photos

Nachtrag Nr. 22 / 10 V0
Ext. Nr.

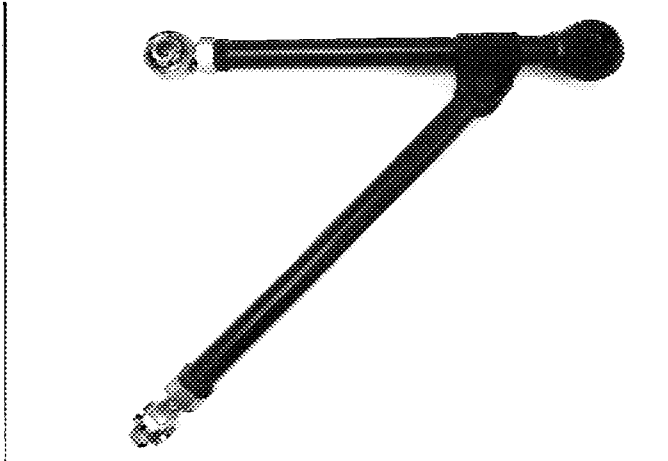
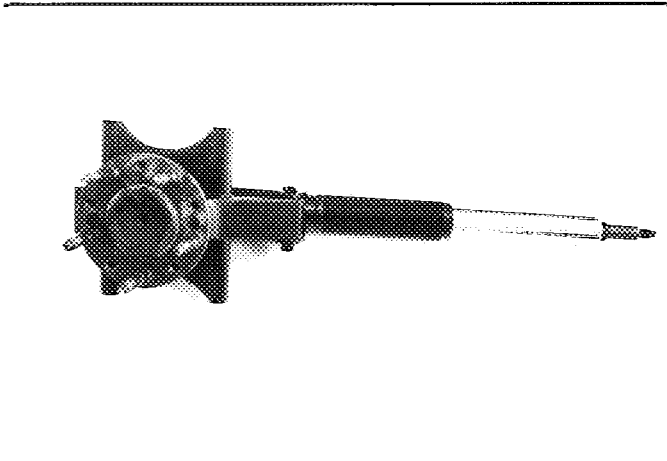
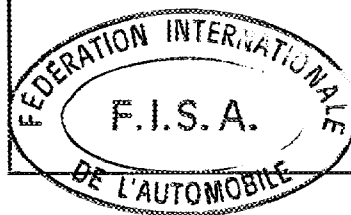
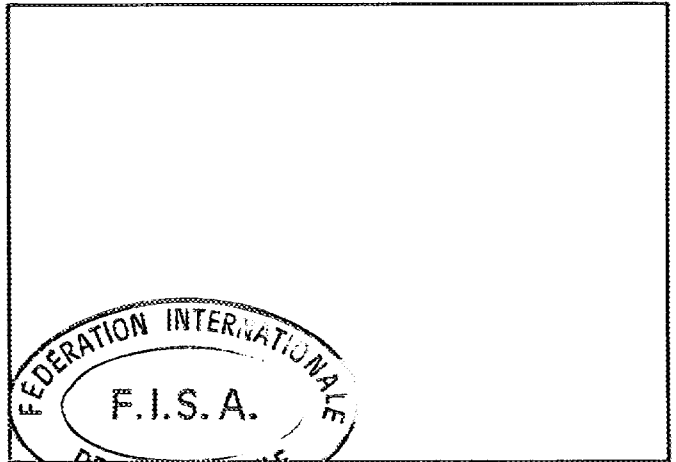
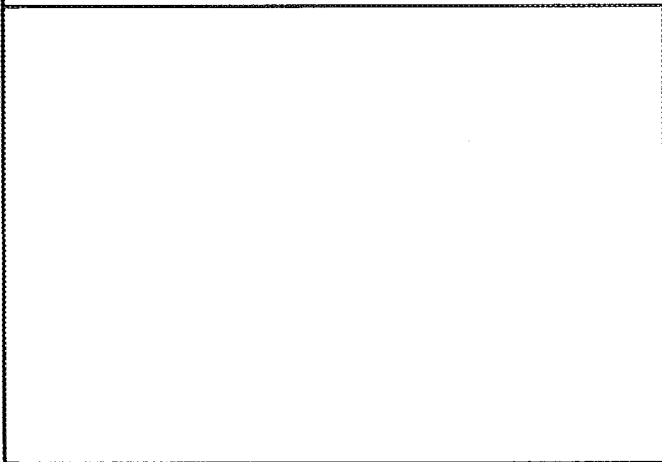
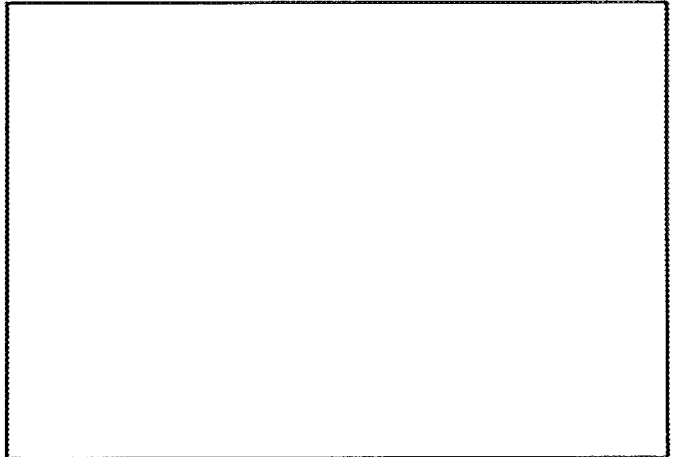
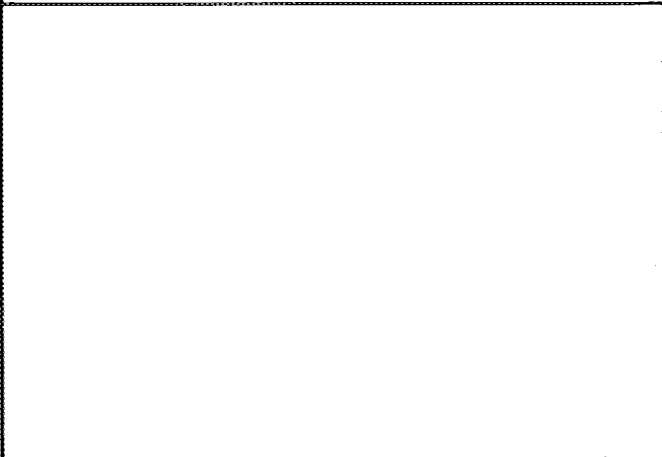

Photo 1

Photo 2





FEDERATION INTERNATIONALE DU SPORT AUTOMOBILE

Homologation N°

A-5327

Extension N°

23 / 08 ER

FICHE D'EXTENSION A L'HOMOLOGATION OFFICIELLE FISA
FORM OF EXTENSION TO THE OFFICIAL FISA HOMOLOGATION

- ES** Evolution sportive du type / Sporting evolution of the type
- ET** Evolution normale du type / Normal evolution of the type
- VF** Variante de fourniture / Supply variant
- VO** Variante option / Option variant
- ER** Errata / Erratum

Homologation valable dès le 01 JAN. 1989 en groupe A
Homologation valid as from _____ in group _____

Constructeur BMW Motorsport GmbH Modèle et type M3
Manufacturer _____ Model and type _____

Page ou ext. Page or ext.	Art. Art.	Description Description
------------------------------	--------------	----------------------------

All the weights of the parts mentioned on
erratum 21/07 ER are to be disregarded.

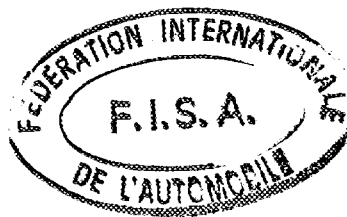

FÉDÉRATION INTERNATIONALE DU SPORT AUTOMOBILE
ONS Oberste Nationale Sportkommission für den Automobilsport in Deutschland GmbH

Homologation Nr.

A-5327

Nachtrag Nr.
Extension Nr.

24 / 11 VO

Nachtrag zum offiziellen Testblatt der FISA
Form of extension to the official FISA-Homologation

- ET** Normale Weiterentwicklung des Typs: ab Fahrgestell -Nr.: _____
Normal evolution of the type: as from chassis number:
- ES** Sportevolution
Sporting evolution
- VF** Liefervariante
Supply variant
- VO** Ausstattungsvariante
Option variant
- ER** Berichtigung
Erratum

Homologation gültig ab: 1.4.89 in Gruppe: A
Homologation valid as from

Hersteller: BMW Motorsport GmbH Modell und Typ: BMW M3
Manufacturer

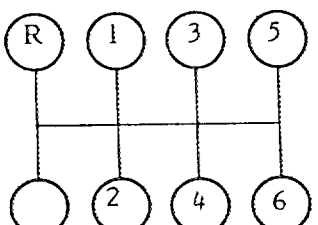
Seite od. Nachtrag Page or ext.	Artikel Art.	Beschreibung Description																															
Seite page 6	603	Zusätzliches Getriebe additional gearbox	Foto 1																														
	603E	<table border="1"> <thead> <tr> <th colspan="3">Zusätzl. Getriebe Additional: G B</th> </tr> <tr> <th>Über- setzungen ratio</th> <th>Anzahl der Zähne number of teeth</th> <th>synchro.</th> </tr> </thead> <tbody> <tr><td>1</td><td>2,466</td><td>38:16 *</td></tr> <tr><td>2</td><td>1,913</td><td>35:19 *</td></tr> <tr><td>3</td><td>1,537</td><td>37:25 *</td></tr> <tr><td>4</td><td>1,309</td><td>29:23 *</td></tr> <tr><td>5</td><td>1,133</td><td>24:22 *</td></tr> <tr><td>6</td><td>1,000</td><td>- *</td></tr> <tr><td>R</td><td>2,745</td><td>21:37 14:21</td></tr> <tr><td>C</td><td>1,0384</td><td>27:26</td></tr> </tbody> </table>	Zusätzl. Getriebe Additional: G B			Über- setzungen ratio	Anzahl der Zähne number of teeth	synchro.	1	2,466	38:16 *	2	1,913	35:19 *	3	1,537	37:25 *	4	1,309	29:23 *	5	1,133	24:22 *	6	1,000	- *	R	2,745	21:37 14:21	C	1,0384	27:26	<p>Valid only for 04/01 ET and 14/01 ES</p>  
Zusätzl. Getriebe Additional: G B																																	
Über- setzungen ratio	Anzahl der Zähne number of teeth	synchro.																															
1	2,466	38:16 *																															
2	1,913	35:19 *																															
3	1,537	37:25 *																															
4	1,309	29:23 *																															
5	1,133	24:22 *																															
6	1,000	- *																															
R	2,745	21:37 14:21																															
C	1,0384	27:26																															

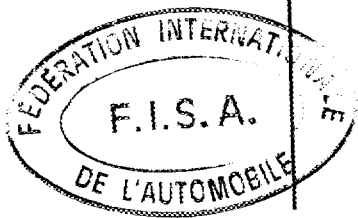

Marke BMW
Make

Modell M3
Model

Homologations Nr. A-5327
Homologation Nr

Fotos
Photos

Nachtrag Nr. 24 / 11 VO
Ext. Nr.



Foto 1



FÉDÉRATION INTERNATIONALE DU SPORT AUTOMOBILE

ONS Oberste Nationale Sportkommission für den Automobilsport in Deutschland GmbH

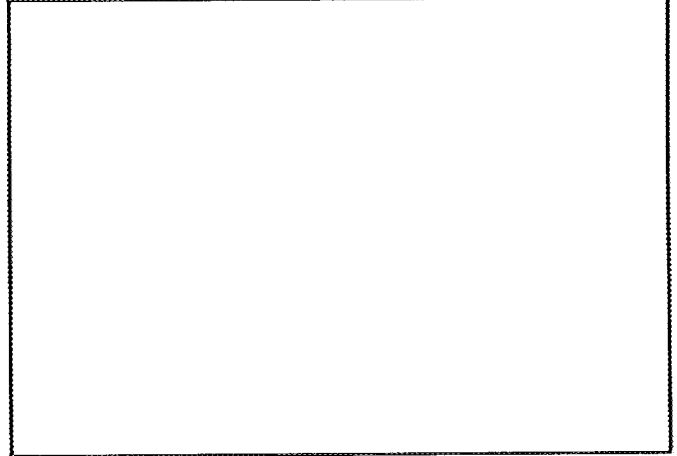
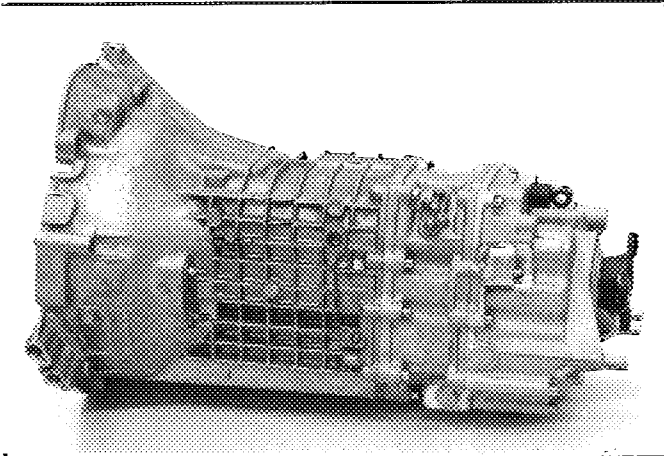
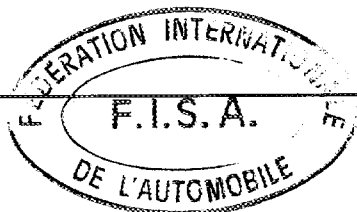
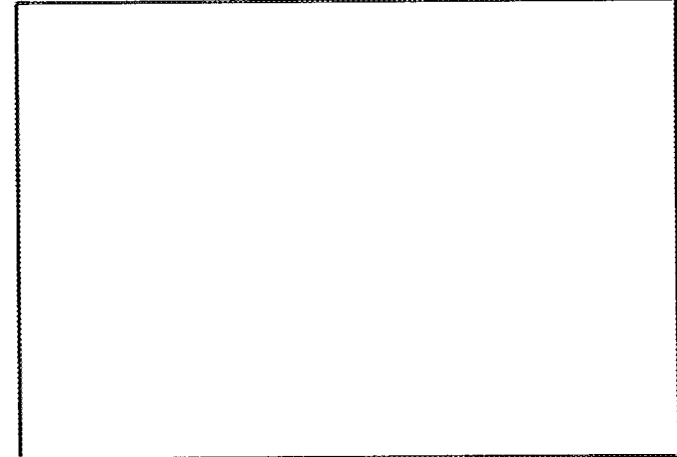
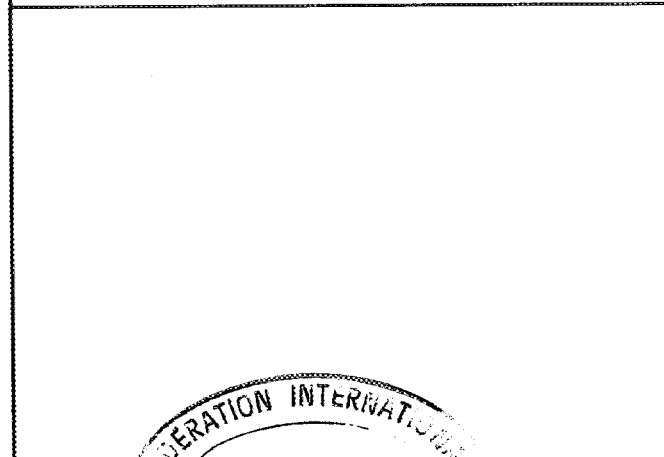
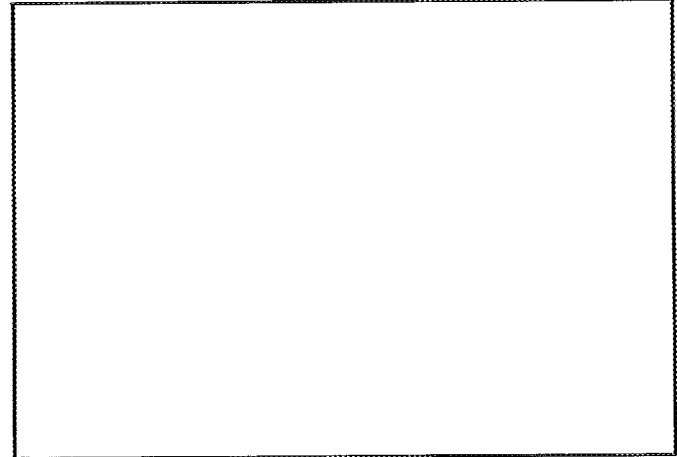
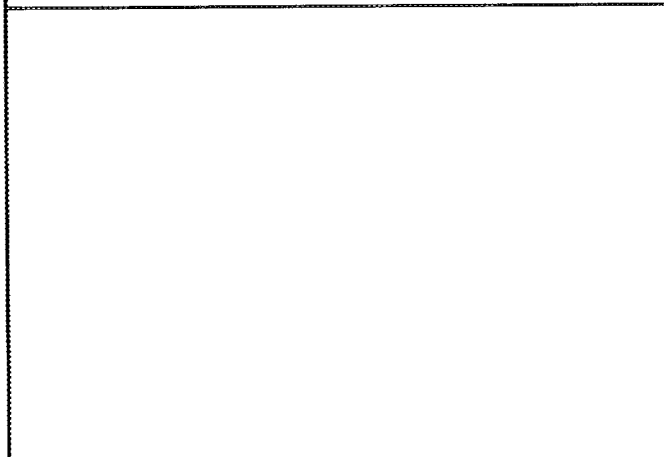
Homologation Nr.

A-5327

Nachtrag Nr.
Extension Nr.

25 / 04 VF

Nachtrag zum offiziellen Testblatt der FISA

Form of extension to the official FISA-Homologation

ET Normale Weiterentwicklung des Typs: ab Fahrgestell -Nr.: _____
Normal: evolution of the type: as from chassis number:

ES Sportevolution
Sporting evolution

VF Liefervariante
Supply variant

VO Ausstattungsvariante
Option variant

ER Berichtigung
Erratum

NOT VALID IN RALLIES
VALID ONLY FOR 14/01 ES

Homologation gültig ab: 1.4.89 in Gruppe: A
Homologation valid as from: in group

Hersteller: BMW Motorsport GmbH Modell und Typ: BMW M3
Manufacturer Model and type

Seite od. Nachtrag Page or ext.	Artikel Art.	Beschreibung Description
Seite 9 page	902H	Sicherheitsglas (3 mm) für Heckscheibe safety glass (3 mm) for rear window
	902I	Sicherheitsglas (3 mm) für hintere Seitenscheiben safety glass (3 mm) for rear side windows

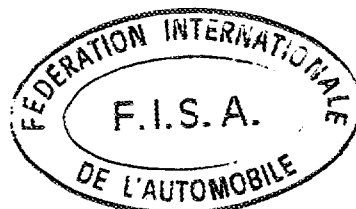

A-5327

26 / 12 VO

Nachtrag zum offiziellen Testblatt der FISA

Form of extension to the official FISA-Homologation

- ET** Normale Weiterentwicklung des Typs; ab Fahrgestell -Nr.: _____
Normal: evolution of the type, as from chassis number.
- ES** Sportevolution
Sporting evolution
- VF** Liefervariante
Supply variant
- VO** Ausstattungsvariante
Option variant
- ER** Berichtigung
Erratum

Homologation gültig ab: 1.4.89 in Gruppe: A
Homologation valid as from: in group

Hersteller: BMW Motorsport GmbH Modell und Typ: BMW M3
Manufacturer: Model and type

Seite od. Nachtrag Page or ext.	Artike Art.	Beschreibung Description	
Seite 7	606	Verstärkte Gelenkwelle - reinforced propellershaft Material: Carbonfiber	Foto 1
	606	Verstärkte Gelenkwelle - reinforced propellershaft Material: Stahl - steel	Foto 2
	605	Verstärktes Hinterachsgetriebegehäuse - reinforced rear-axle housing	Foto 3
	605	Verstärktes Hinterachsgetriebegehäuse - reinforced rear-axle housing	Foto 4
	701A	Verstärkter Querlenker, Aluminium - reinforced control arm, aluminium	Foto 5
	701B	Verstärkte Hinterradaufhängung - reinforced rear suspension	Foto 6
	701A	Verstellbarer Rohrstabilisator - adjustable hollow tube antirollbar	Foto 7
	701B	Verstellbarer Rohrstabilisator - adjustable hollow tube antirollbar	Foto 8
	701A	Anlenkpunkte des Querlenkers verstärkt und um max. +/- 20 mm modifiziert - mounting points for lower control arm reinforced and max. +/- 20 mm modified	

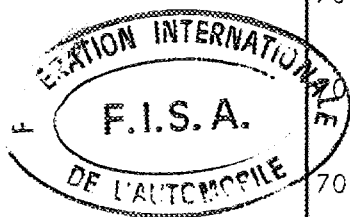

Marke BMW
 Make

Modell M3
 Model

Homologations Nr. A-5327
 Homologation Nr.

Nachtrag Nr. 26 / 12 VO
 Ext. Nr.

Seite od. Nachtrag Page or ext.	Artikel Art.	Beschreibung Description	
Seite 8		Bremssattel vorne - brake caliper front	Foto 9
	803E	4	
	803E1	2 x 44,5 + 2 x 41,3	
	803G1	2	
	803G2	1	
	803G3	Aluminium	
		Bremssattel hinten - brake caliper rear	Foto 10
	803E	4	
	803E1	wahlweise - alternative 2 x 31,75 + 2 x 34,92 or 4 x 31,75 or 4 x 36,0 or 2 x 31,75 + 2 x 36,0	
	803G1	2	
803G2	1		
803G3	Aluminium		
Seite 9		Bremsscheibe vorne - brake disc front Material: Carbonfiber	Foto 11
	803G4	35,0 + 1 mm - 5 mm	
	803G5	330 +- 1,5 mm	
	803G6	330 +- 1,5 mm	
	803G7	222 +- 1,5 mm	
	803G8	128 +- 1,5 mm	
	803G9	Ja - yes	
		Bremsscheibentopf - brake disc mounting bell	Foto 11A
		Bremsscheibe hinten - brake disc rear Material: Carbonfiber	Foto 12
	803G4	28,0 + 1 mm - 5 mm	
803G5	280 +- 1,5 mm		
803G6	280 +- 1,5 mm		
803G7	178,4 +- 1,5 mm		
803G8	112,25 +- 1,5 mm		
803G9	Ja - yes		
Extension 01-01 VO		Bremsscheibentopf - brake disc mounting bell	Foto 12A
		Foto V2 + V2A Geänderte Bremsscheibe, Maße unverändert - changed brake disc, measurements unchanged	Foto 13
		Foto W2 + W2A Geänderte Bremsscheibe, Maße unverändert - changed brake disc, measurements unchanged	Foto 14

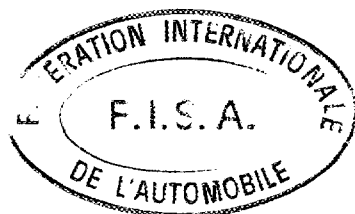

Marke BMW
Make

Modell M3
Model

Homologations Nr. A-5327
Homologation Nr.

Fotos
Photos

Nachtrag Nr. 26 / 12 V0
Ext. Nr.



Foto 1



Foto 2

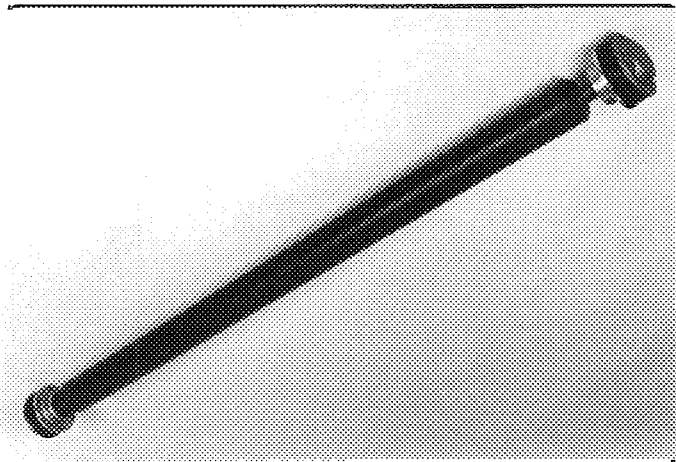

Foto 3

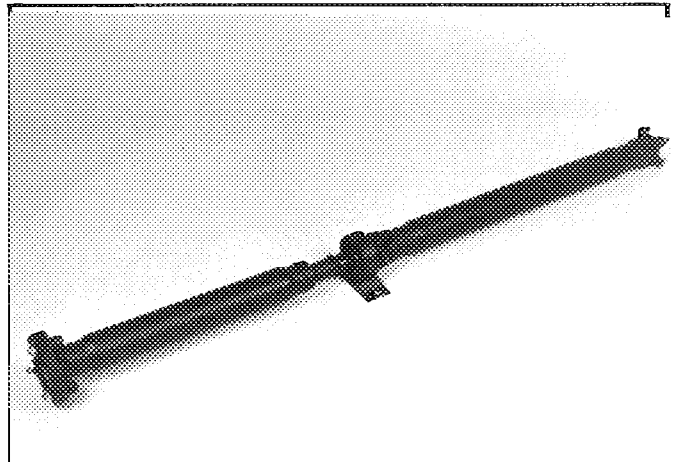

Foto 4

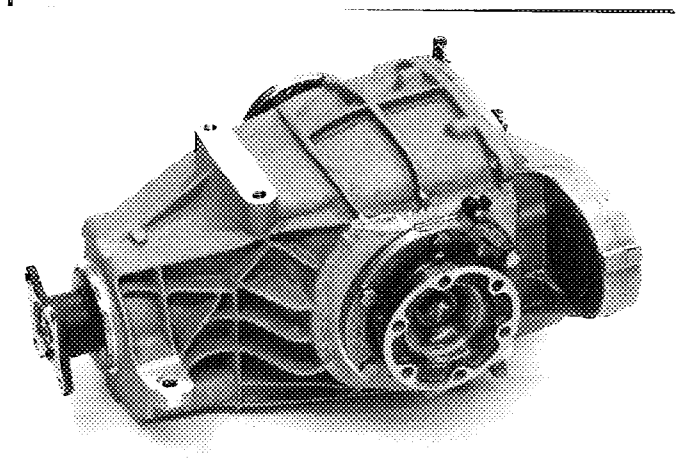

Foto 5

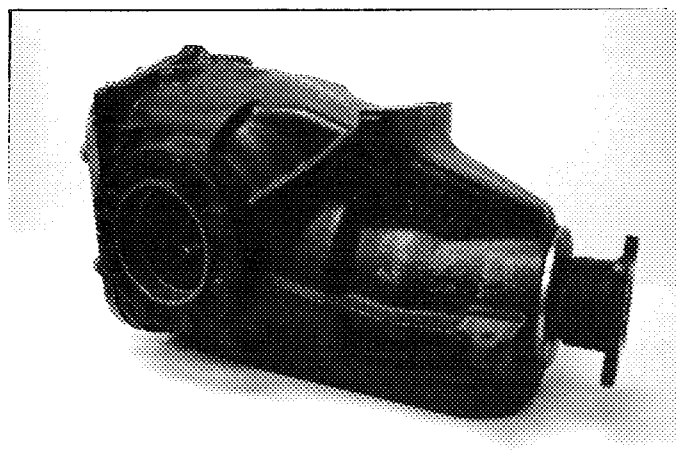

Foto 6

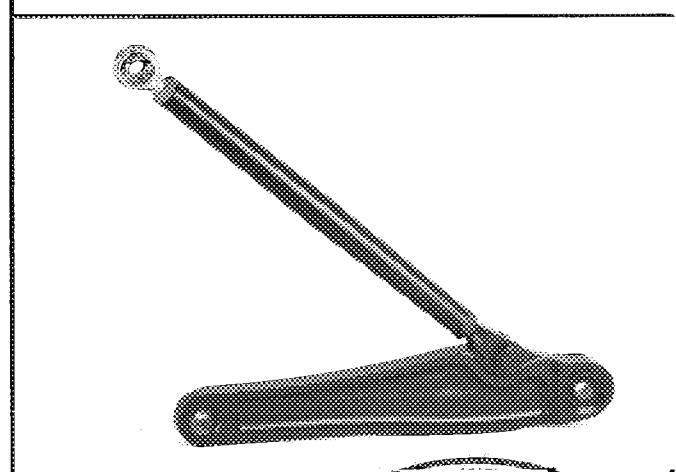

Marke BMW
Make

Modell M3
Model

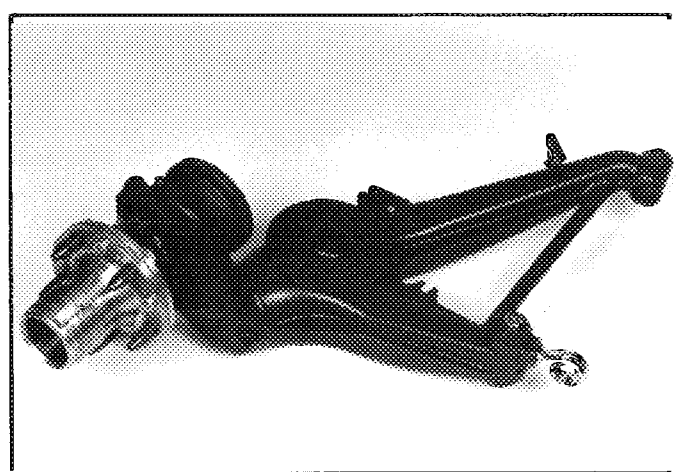
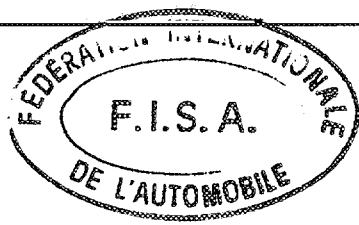
Homologations Nr. A-5327
Homologation Nr.

Fotos
Photos

Nachtrag Nr. 26 / 12 V0
Ext. Nr.



Foto 7



Foto 8

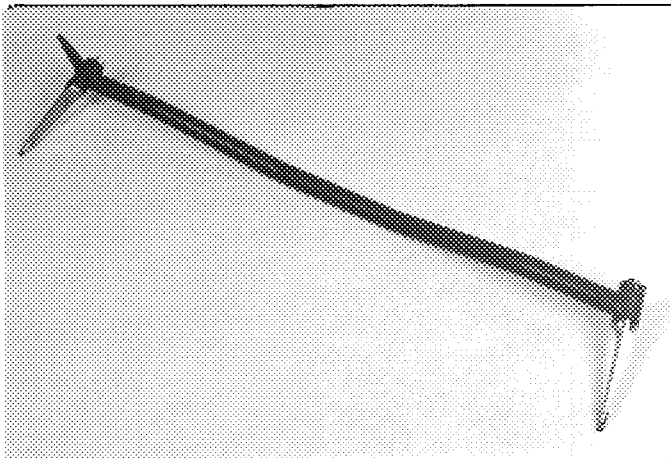

Foto 9

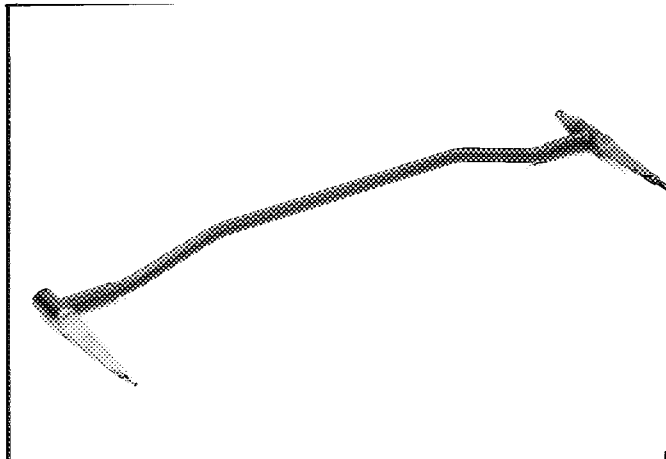

Foto 10

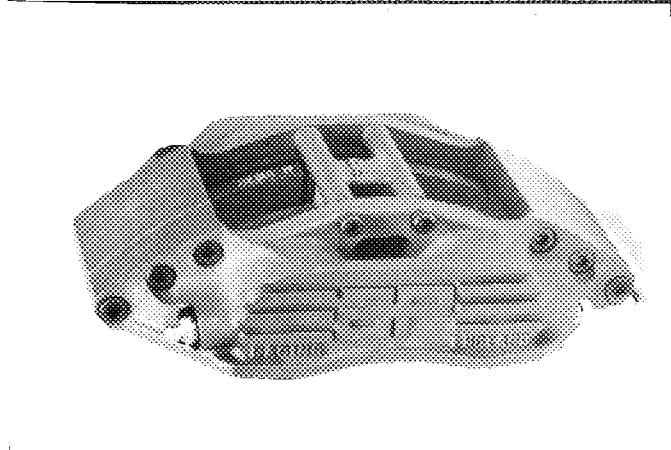

Foto 11

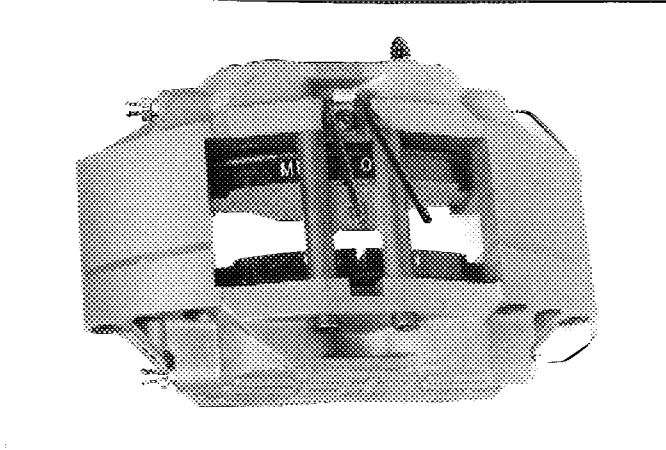

Foto 11A

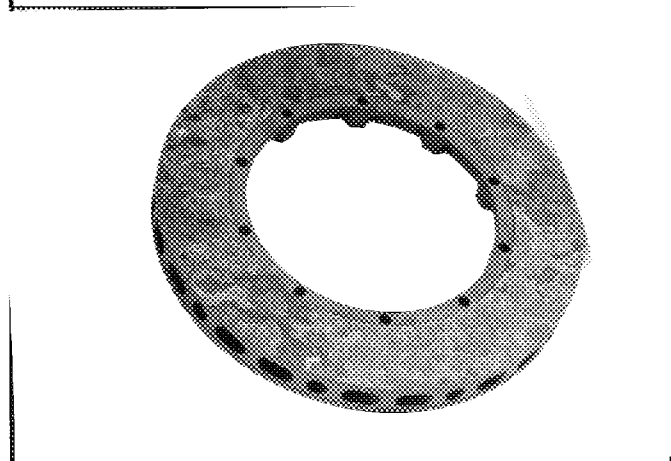

Marke BMW
Make

Modell M3
Model

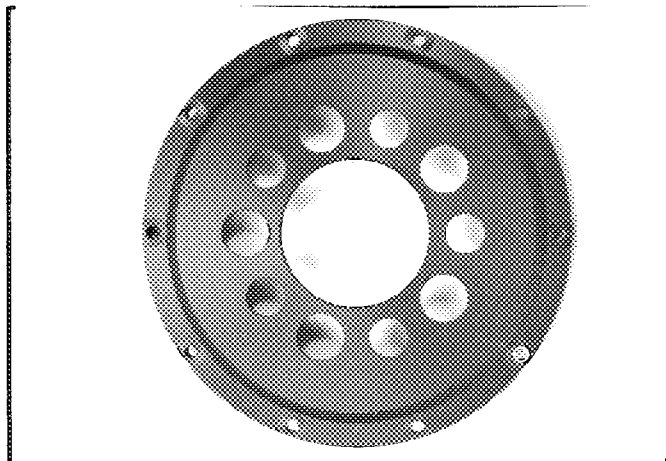
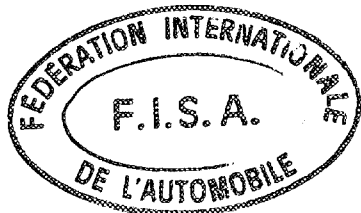
Homologations Nr. A-5327
Homologation Nr.

26 / 12 V0

Fotos
Photos

Nachtrag Nr. _____
Ext. Nr.



Foto 12

Foto 12A

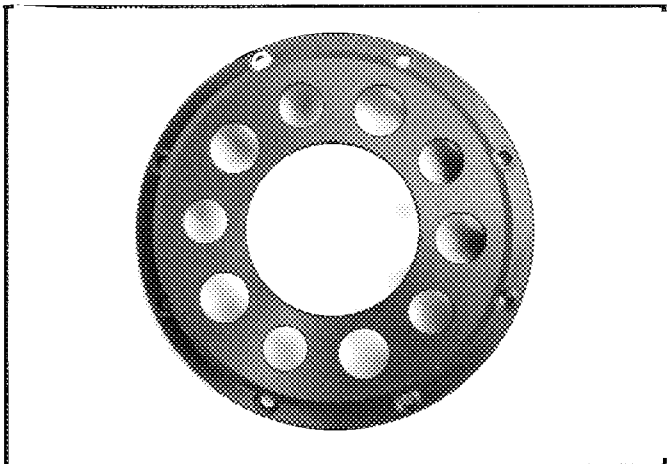
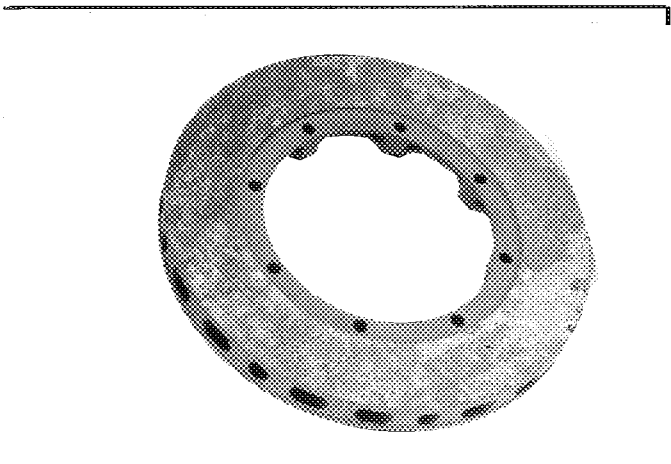

Foto 13

Foto 14

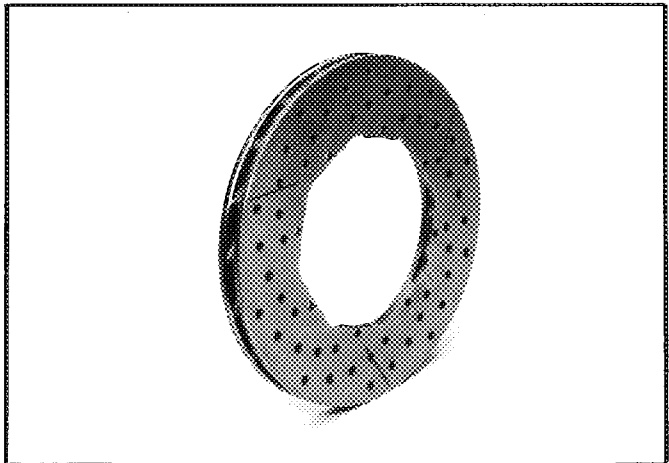
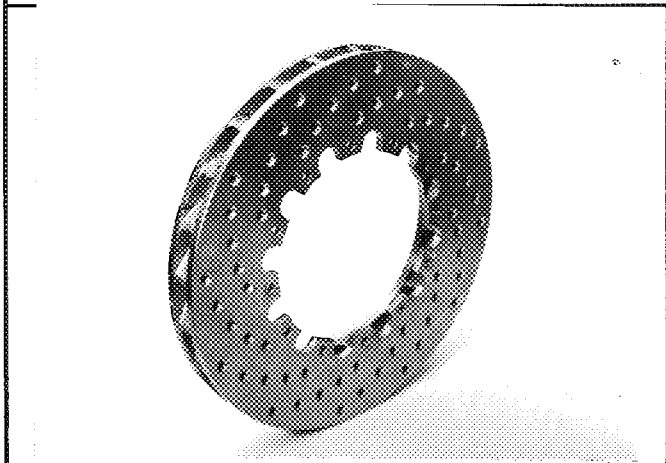
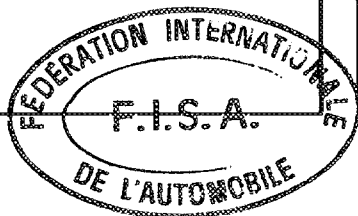
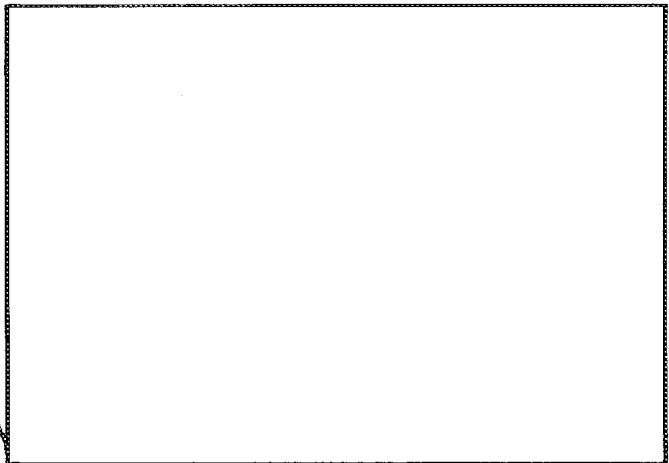
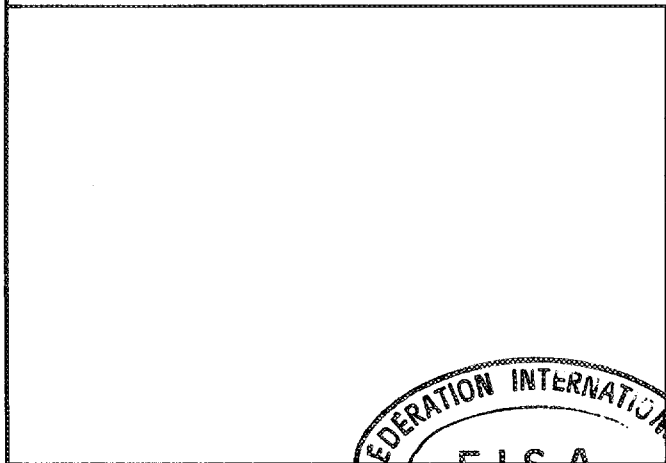

FÉDÉRATION INTERNATIONALE DU SPORT AUTOMOBILE

ONS Oberste Nationale Sportkommission für den Automobilsport in Deutschland GmbH

Homologation Nr.

A-5327

Nachtrag Nr.
Extension Nr.

27 / 13 VO

Nachtrag zum offiziellen Testblatt der FISA

Form of extension to the official FISA-Homologation

- ET** Normale Weiterentwicklung des Typs: ab Fahrgestell-Nr.: _____
Normal: evolution of the type, as from chassis number.
- ES** Sportevolution
Sporting evolution
- VF** Liefervariante
Supply variant
- VO** Ausstattungsvariante
Option variant
- ER** Berichtigung
Erratum

Homologation gültig ab: 1. Juli 1989 in Gruppe: A
Homologation valid as from: _____ in group: _____

Hersteller: BMW Motorsport GmbH Modell und Typ: BMW M3
Manufacturer: _____ Model and type: _____

Seite od. Nachtrag Page or ext.	Artikel Art.	Beschreibung Description	
Seite 7	701A	Federbeinstützlager, einstellbar Top mounting plate, adjustable	Foto 1
Seite 7	701A	Federbeinstützlager, einstellbar Top mounting plate, adjustable	Foto 2
Seite 7	701B	Verstärkte Stoßdämpferaufnahme, hinten Reinforced shock-absorber mounting, rear	Foto 3
Seite 7	605B 605C 605B 605C	4,88:1 44:9 5,12:1 41:8	
Seite 9	804A	Zahnstangenlenkung mit Lenkhilfe Rack and pinion steering, power assisted	Foto 4
	803B1	Bohrung / bore: 15,9 mm, 17,8 mm, 19,1 mm, 20,6 mm, 22,2 mm, 23,8 mm, 25,4 mm	Foto 5
	603D	Verstärkte Schaltkonsole Reinforced gear shift lever	Foto 6

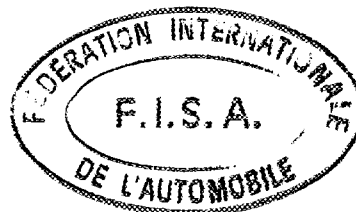

Marke BMW
 Make

Modell M3
 Model

Homologations Nr. A-5327
 Homologation Nr.

Nachtrag Nr. 27 / 13 VO
 Ext. Nr.

Seite od. Nachtrag Page or ext.	Artikel Art	Beschreibung Description
Seite 8	803E 803E1 803G1 803G2 803G3	Bremssattel hinten / Brake caliper, rear 4 wahlweise - alternative 2 x 31,75 + 2 x 38,1; 2 x 33,9 + 38,1 (Diese Abmessungen auch möglich für Nachtrag 26/12 VO Foto 10 / These dimensions also possible for extension 26/12 VO Foto 10) 2 1 Aluminium
Nachtrag/ Extension 26/12 VO	803G4	zu Foto 11 = zusätzlich 32+1-5mm Alle anderen Maße unverändert / to Foto 11 = additionally 32+1-5mm All other dimensions unchanged
Nachtrag/ Extension 26/12 VO	803G4	zu Foto 12 = zusätzlich 23+1-5mm Alle anderen Maße unverändert / to Foto 12 = additionally 23+1-5mm All other dimensions unchanged

Foto 7

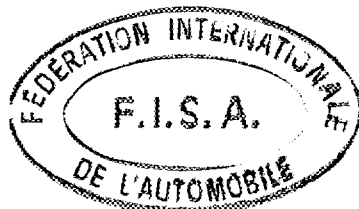

Marke BMW
Make

Modell M3
Model

Homologations Nr. A-5327
Homologation Nr.

Fotos
Photos

Nachtrag Nr. 27 / 13 VO
Ext. Nr.



Foto 1



Foto 2

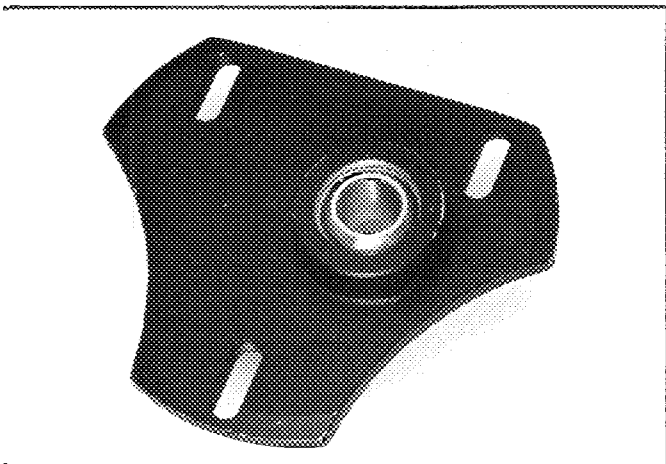

Foto 3

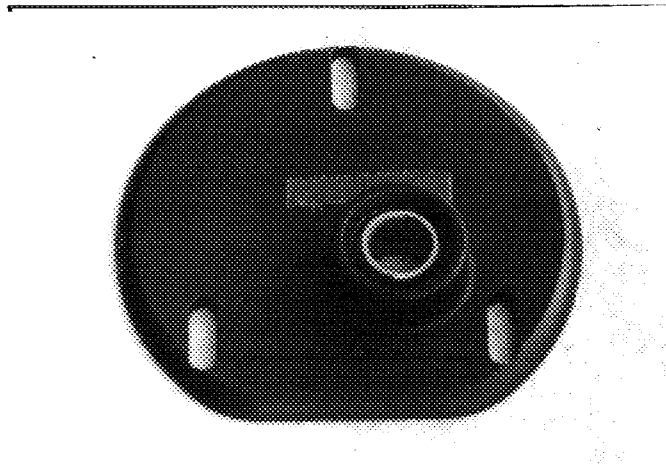

Foto 4

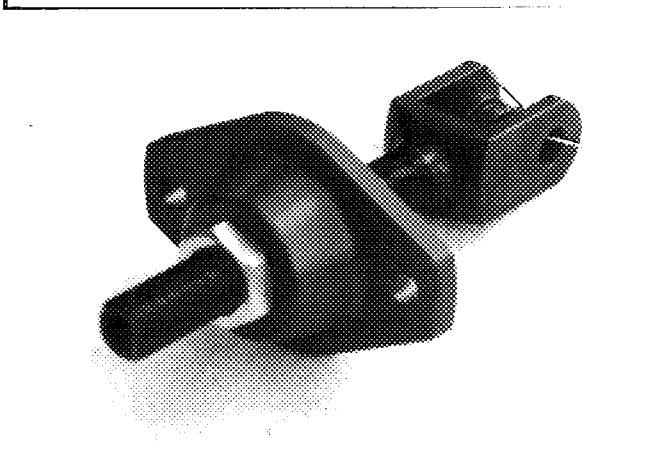

Foto 5

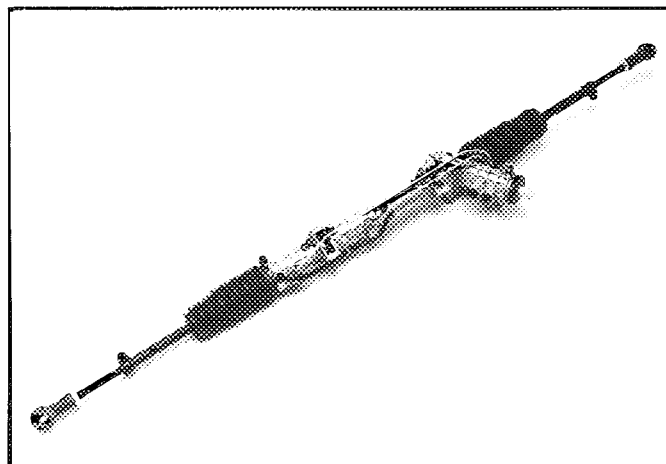

Foto 6

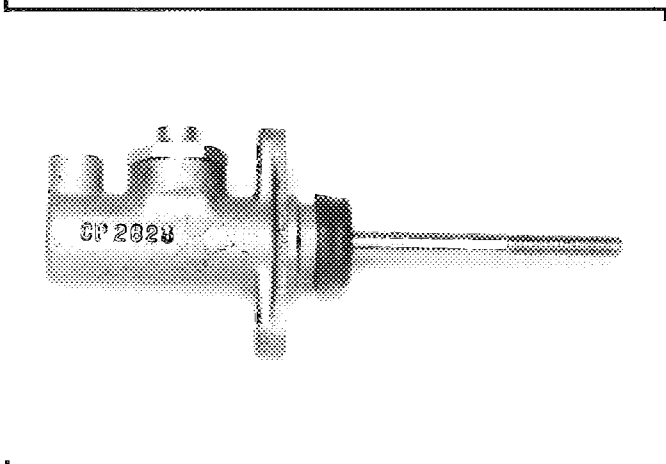

Marke BMW
Make

Modell M3
Model:

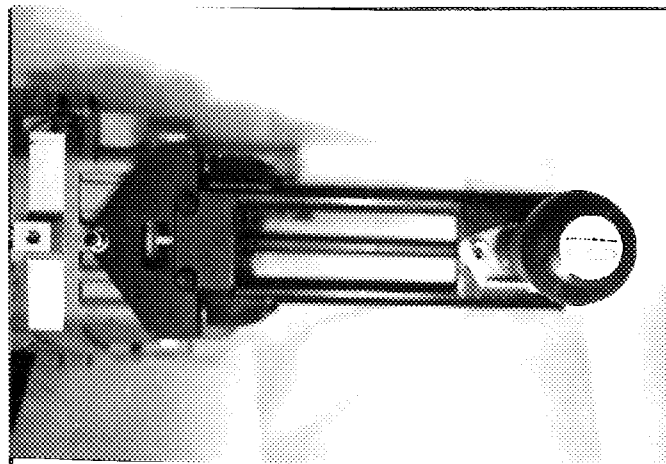
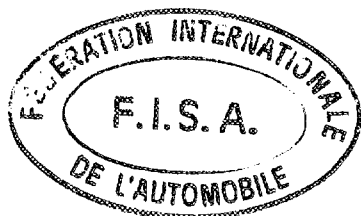
Homologations Nr. A-5327
Homologation Nr.

Fotos
Photos

Nachtrag Nr. 27 / 13 VO
Ext. Nr.



Foto 7



Nachtrag zum offiziellen Testblatt der FISA

Form of extension to the official FISA-Homologation:

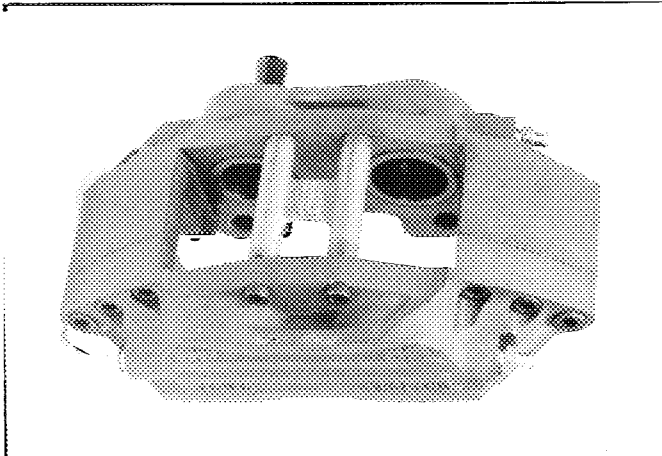
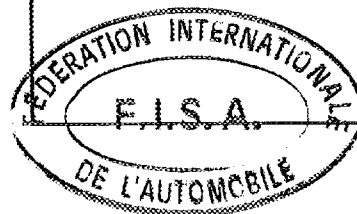
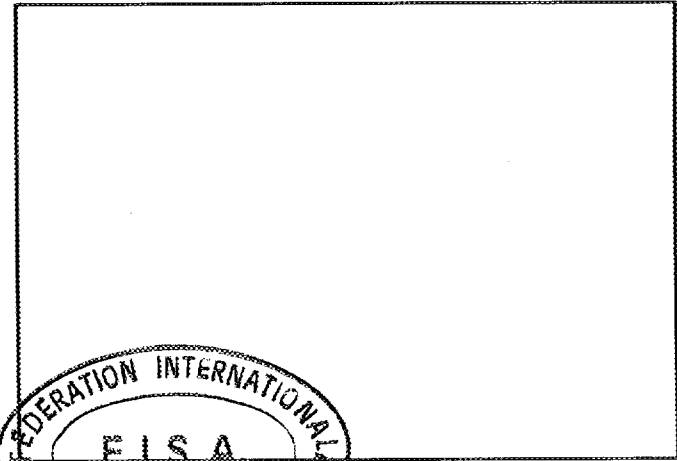
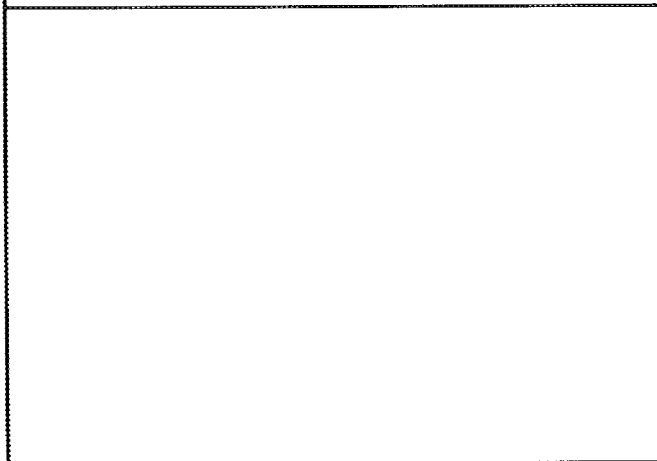
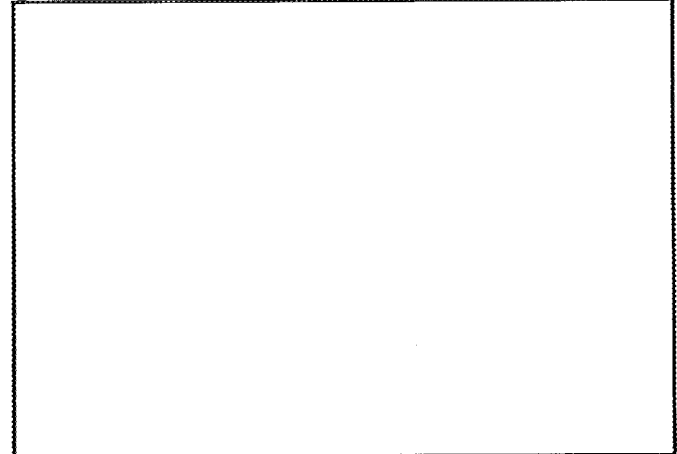
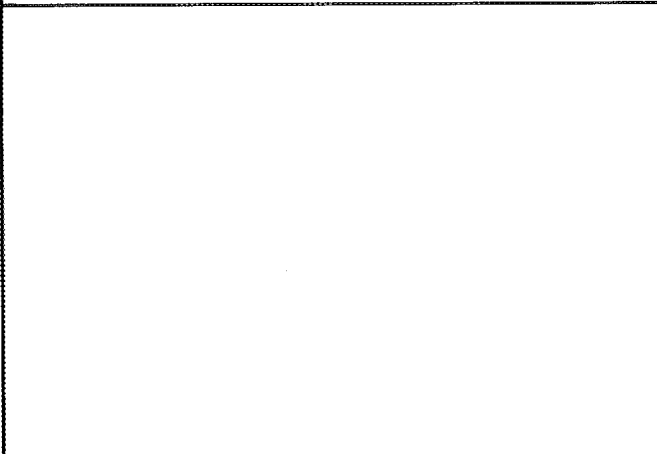
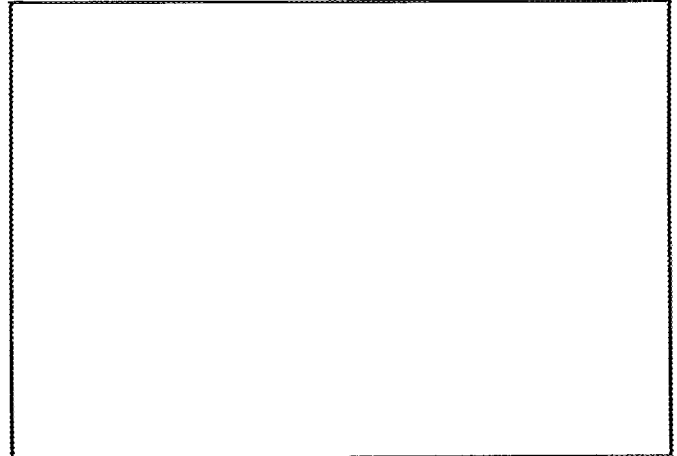
- ET** Normale Weiterentwicklung des Typs; ab Fahrgestell -Nr.: _____
Normal evolution of the type, as from chassis number.
- ES** Sportevolution
Sporting evolution
- VF** Liefervariante
Supply variant
- VO** Ausstattungsvariante
Option variant
- ER** Berichtigung
Erratum

Homologation gültig ab: 1. Oktober 1989 in Gruppe: A
Homologation valid as from: _____ in group: _____

Hersteller: BMW Motorsport GmbH Modell und Typ: BMW M3
Manufacturer: _____ Model and type: _____

Seite od. Nachtrag Page or ext.	Artikel Art	Beschreibung Description	
Seite 8 page	803b 803b1	2 Bohrung/bore: 15,8 mm bis/to 25,5 mm	Foto 1
Seite 9 page	803g4 803g5 803g6 803g7 803g9	VA-Bremsscheibe / front brake disk 32,0 +/- 1 mm 332 +/- 1,5 mm 332 +/- 1,5 mm 225 +/- 1,5 mm ja / yes	Foto 2, 3, 4
<p>Die Bremsscheibe kann glatt (Foto 2), gelocht (Foto 3) oder genutet (Foto 4) ausgeführt sein. The brake disk may be plane (Photo 2), cross dilled (Photo 3) or grooved (Photo 4).</p>			

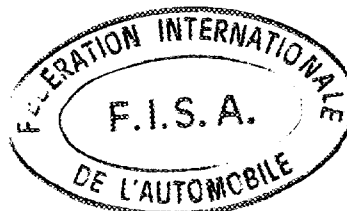

Marke BMW
Make

Modell M3
Model

Homologations Nr. A 5327
Homologation Nr.

28 / 14 VO

Nachtrag Nr. _____
Ext. Nr.

Seite od. Nachtrag Page or ext.	Artikel Art.	Beschreibung Description
Seite 9 page		HA-Bremsscheibe / rear brake disk Foto 5, 6
	803g4	22,2 +/- 1 mm
	803g5	280 +/- 1,5 mm
	803g6	280 +/- 1,5 mm
	803g7	185 +/- 1,5 mm
	803g9	ja / yes
Seite 9 page		Die Bremsscheibe kann glatt (Foto 5), gelocht (Foto 6) oder genutet (Foto W1 / Nachtrag 01/01 VO) ausgeführt werden. The brake disk may be plane (Photo 5), cross dulled (Photo 6) or grooved (Photo W1 / Extension 01/01 VO). Bremsscheibentopf / brake disk mounting bell Foto 7

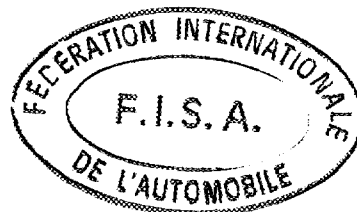

Marke BMW
Make

Modell M3
Model

Homologations Nr. A 5327
Homologation Nr.

Fotos
Photos

Nachtrag Nr. 28 / 14 VO
Ext. Nr.



Foto 1



Foto 2

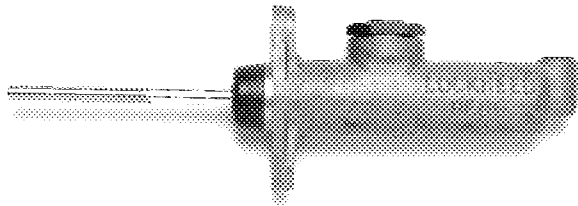

Foto 3

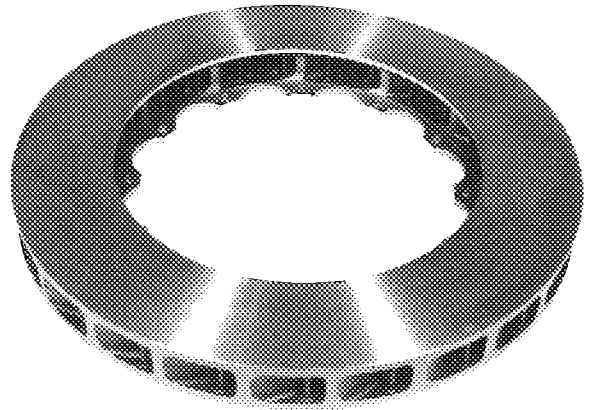

Foto 4

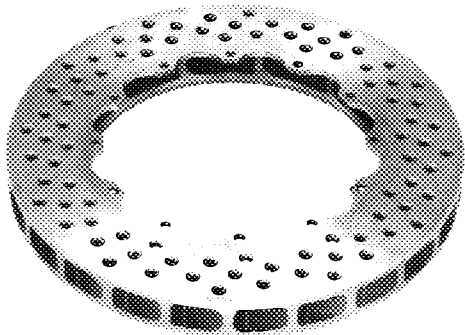

Foto 5

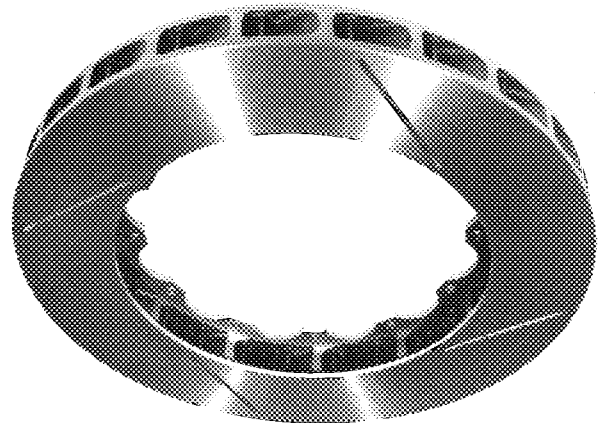

Foto 6

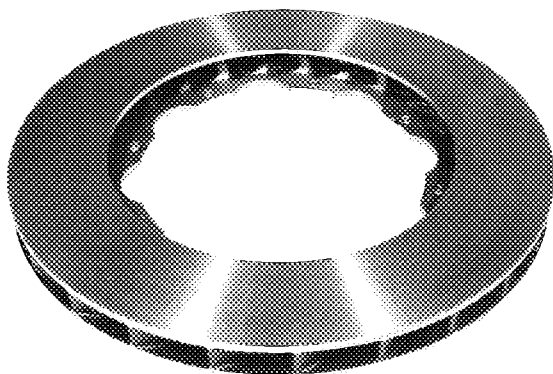

Marke BMW
Make

Modell M3
Model

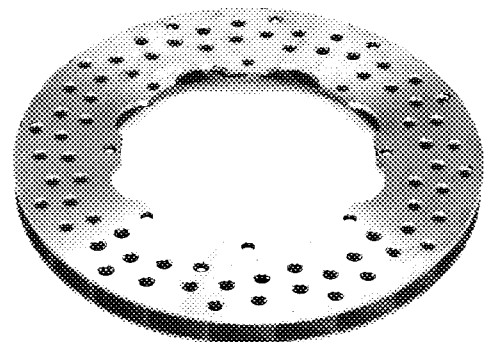
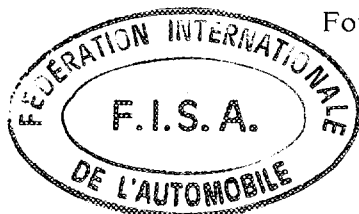
Homologations Nr. A 5327
Homologation Nr.

Fotos
Photos

Nachtrag Nr. 28 / 14 VO
Ext. Nr.



Foto 7



FÉDÉRATION INTERNATIONALE DU SPORT AUTOMOBILE

ONS Oberste Nationale Sportkommission für den Automobilsport in Deutschland GmbH

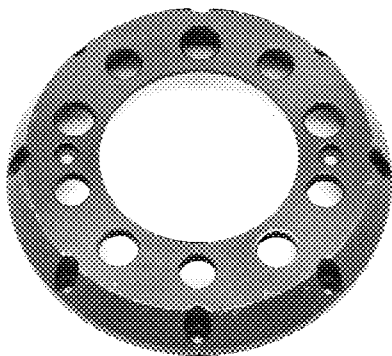
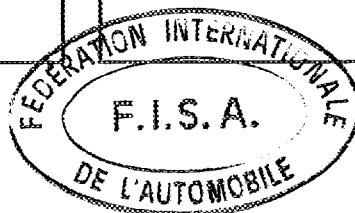
Homologation Nr.

A 5327

Nachtrag Nr.
Extension Nr.

29 / 09 ER

Nachtrag zum offiziellen Testblatt der FISA

Form of extension to the official FISA-Homologation

- ET** Normale Weiterentwicklung des Typs: ab Fahrgestell -Nr.: _____
Normal evolution of the type: as from chassis number:
- ES** Sportevolution
Sporting evolution
- VF** Liefervariante
Supply variant

- VO** Ausstattungsvariante
Option variant

- ER** Berichtigung
Erratum

Homologation gültig ab: 1. Oktober 1989 in Gruppe: A
Homologation valid as from: _____ in group: _____

Hersteller: BMW Motorsport GmbH Modell und Typ: BMW M3
Manufacturer: _____ Model and type: _____

Seite od. Nachtrag Page or ext.	Artikel Art.	Beschreibung Description
Nachtrag Extension 01/01 VO	803G7	zu Foto V7 225 +/- 1,5 mm anstelle/ instead of 232 +/- 1,5 mm
	803G7	zu Foto W1, W4 185 +/- 1,5 mm anstelle/ instead of 178,4 +/- 1,5 mm

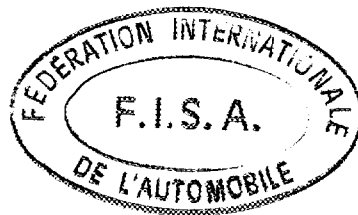

FÉDÉRATION INTERNATIONALE DU SPORT AUTOMOBILE

ONS Oberste Nationale Sportkommission für den Automobilsport in Deutschland GmbH

Homologation Nr.

A 5327

Nachtrag Nr.
Extension Nr.

30 / 15 10

Nachtrag zum offiziellen Testblatt der FISA

Form of extension to the official FISA-Homologation

- ET** Normale Weiterentwicklung des Typs: ab Fahrgestell -Nr.: _____
Normal evolution of the type, as from chassis number:
- ES** Sportevolution
Sporting evolution
- VF** Liefervariante
Supply variant
- VO** Ausstattungsvariante
Option variant
- ER** Berichtigung
Erratum

Homologation gültig ab: 1. Januar 1990 in Gruppe: A
Homologation valid as from: _____ in group: _____

Hersteller: BMW Motorsport GmbH Modell und Typ: BMW M3
Manufacturer: _____ Model and type: _____

Seite od. Nachtrag Page or ext.	Artikel Art.	Beschreibung Description	
Seite 7	605	Verstärktes Hinterachsgetriebe mit geänderter Befestigung / reinforced rear axle housing with changed attachment	Foto 1 + 2 + 3
	605B	4,00 : 1 ; 4,18 : 1 ; 4,36 : 1	
	605C	36 : 9 ; 46 : 11 ; 48 : 11	
	606	Verstärkte Gelenkwelle für 5- + 6-Gang-Getriebe, Längendifferenz 18 mm / reinforced propeller shaft for 5- + 6-speed gearbox, longitudinal difference 18 mm	Foto 4
	606A	Verstärkte Antriebswelle / reinforced drive shaft	Foto 5
	701A	Verstärkte Vorderradaufhängung / reinforced front suspension	Foto 6
	701A	Verstärkte Federbeinstützlager mit Aufnahme / reinforced top mounting plate with attachment	Foto 7
	701A	Verstärkter Stabilisator mit Aufnahme / reinforced anti-roll bar with attachment	Foto 8
	701B	Verstärkte Hinterachsaufhängung mit Aufnahme / reinforced rear suspension with attachment	Foto 9
	701B	Verstärkter Stabilisator mit Aufnahme / reinforced anti-roll bar with attachment	Foto 10
	707B	Feder/Dämpfer Einheit, hinten / spring/damper unit, rear Federposition veränderte / spring position altered	Foto 11

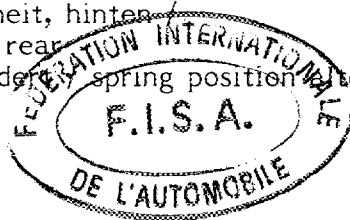

Seite (Page) 1/1

Seite od. Nachtrag Page or ext.	Artikel Art.	Beschreibung Description	
Seite 8	803	Bremssattel passend zu allen Bremsscheiben mit Außendurchmesser 332,0 +/- 1,5 mm / brake caliper for all homologated brake disks with outside diameter 332,0 +/- 1,5 mm	
	803E	6	Foto 12
	803E1	Wahlweise / alternative 2 x 41,2; 2 x 38,1; 2 x 34,9; 2 x 31,7; 2 x 28,5	
	803G7	241,0 +/- 1,5 mm	
	803G8	152,0 +/- 1,5 mm	
		Bremssattel hinten / brake caliper rear	
	803E	4	
	803E1	Wahlweise / alternative 2 x 31,75 + 2 x 34,92 oder/or 4 x 31,75 oder/or 4 x 36,0 oder/or 2 x 31,75 + 2 x 36,0	
	803G1	2	
	803G2	1	
	803G3	Aluminium	Foto 13 + 14
Seite 8	804A	Verstärkte Zahnstangenlenkung mit geänderter Spurstange / reinforced rack + pinion steering with changed steering rod	Foto 15
Seite 9	901G	Ausstellfenster hinten, stufenlos zu öffnen / vent window rear, continuously adjustable	Foto 16

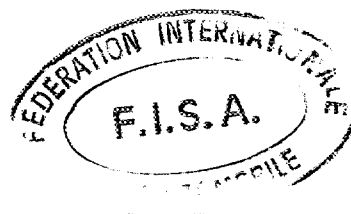

Marke BMW
Make

Modell M3
Model

Homologations Nr. A 5327
Homologation Nr.

Fotos
Photos

Nachtrag Nr. 30 / 15 VO
Ext. Nr.



Foto 1



Foto 2

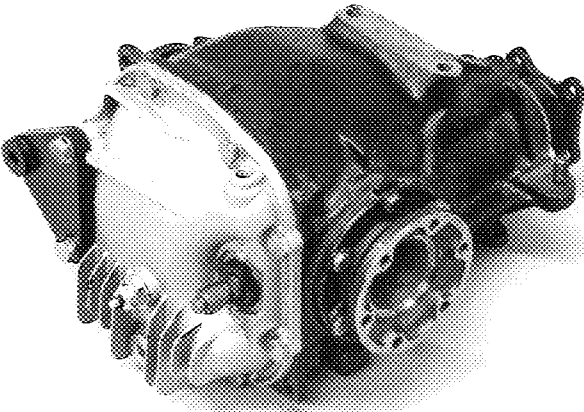

Foto 3

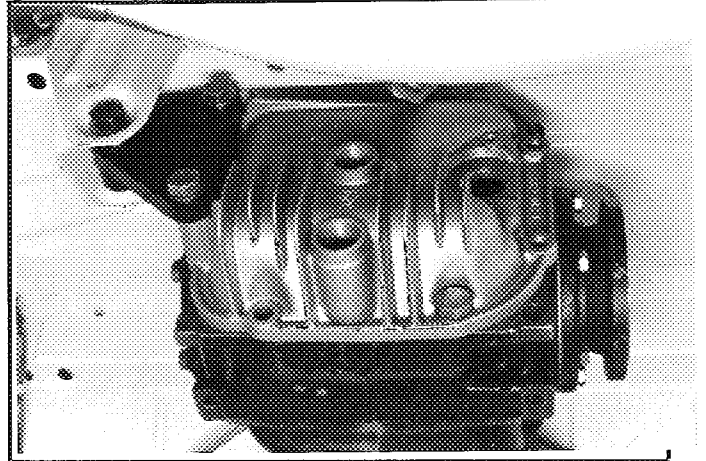

Foto 4

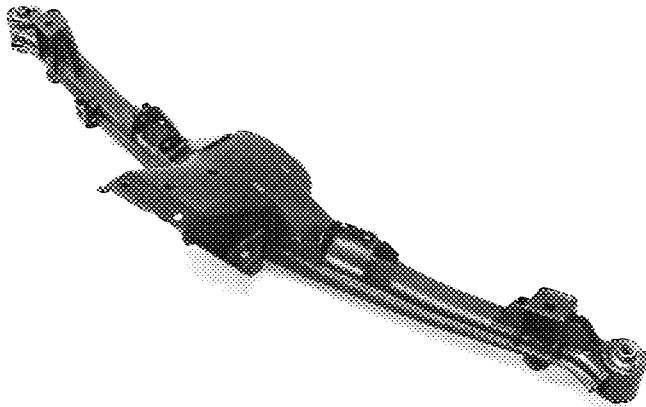

Foto 5

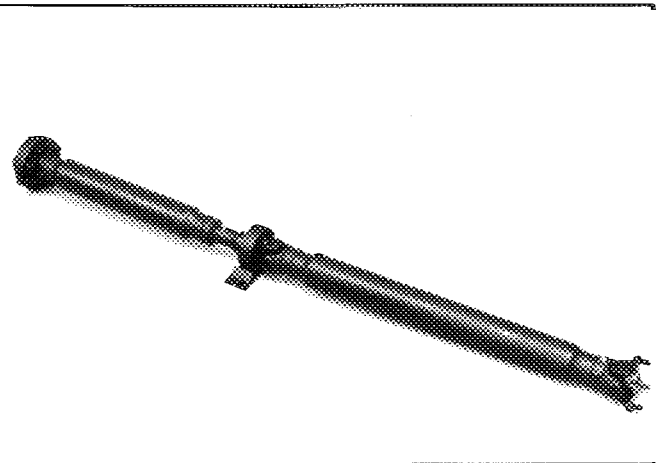

Marke BMW
Make

Modell M3
Model

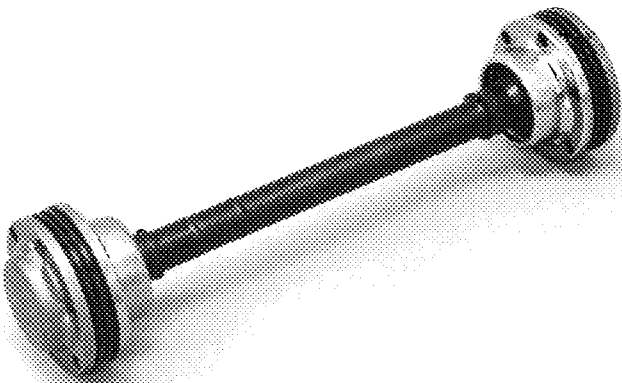
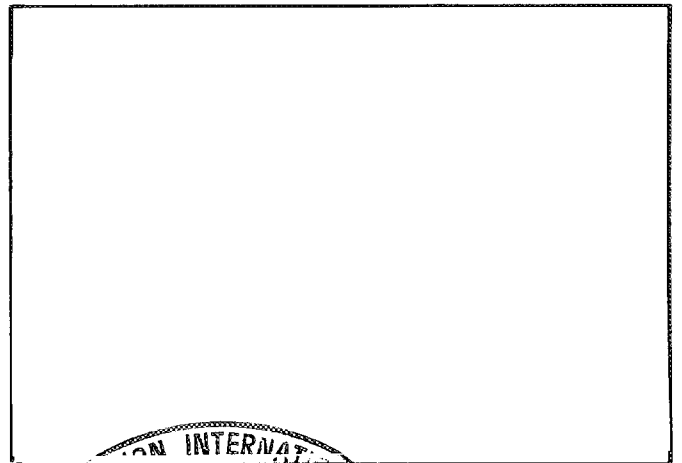
Homologations Nr. A 5327
Homologation Nr.

Fotos
Photos

Nachtrag Nr. 30 / 15 VO
Ext. Nr.



Foto 6



Foto 7

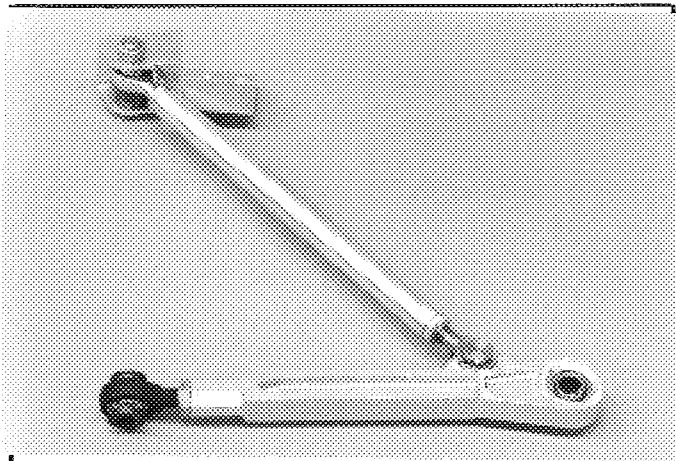

Foto 8

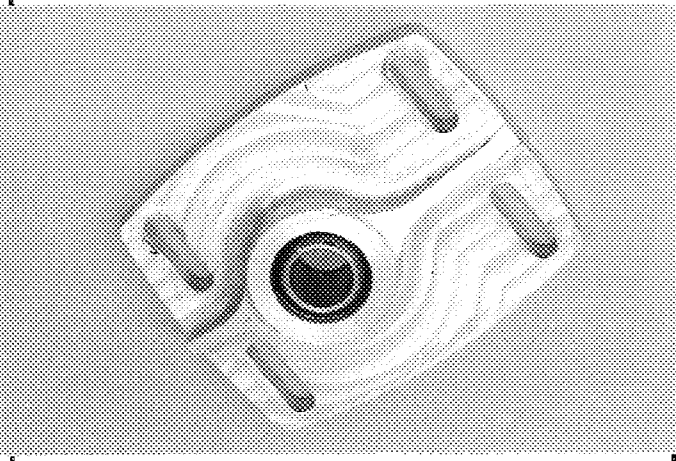
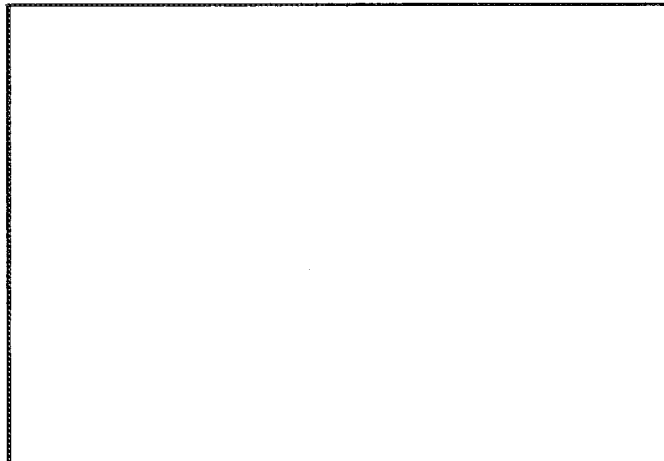

Marke BMW
Make

Modell M3
Model

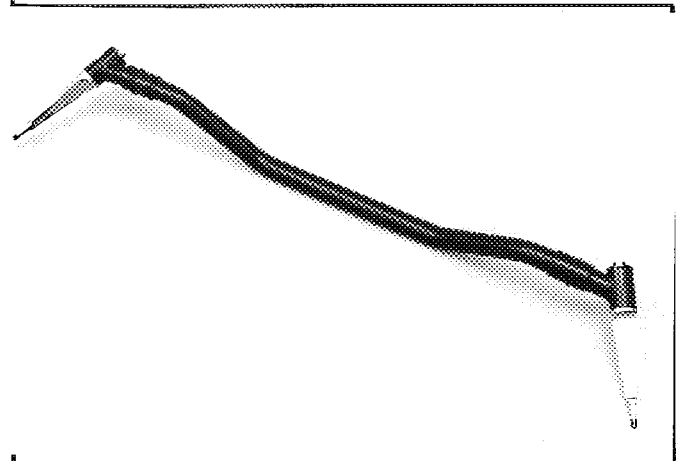
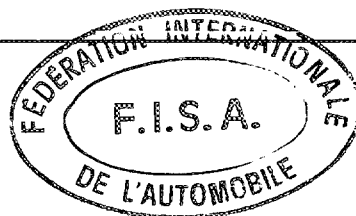
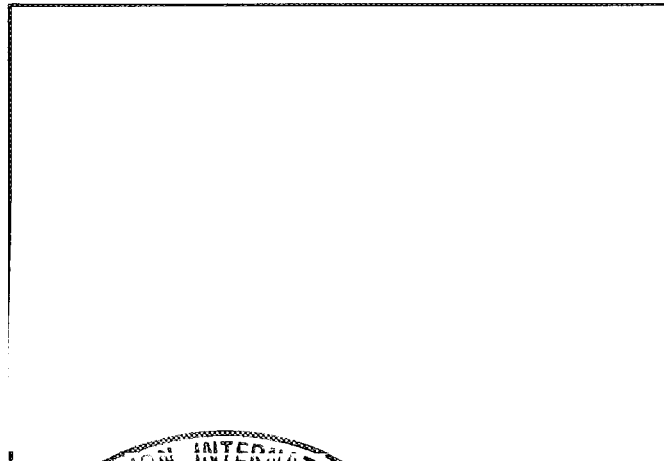
Homologations Nr. A 5327
Homologation Nr.

30 / 15 VQ

Fotos
Photos

Nachtrag Nr. _____
Ext. Nr.



Foto 7



Foto 10

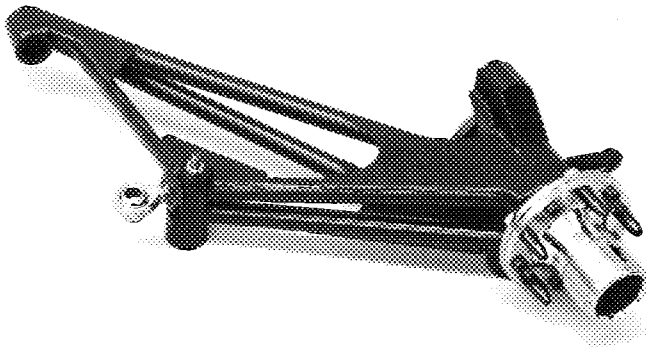

Foto 11

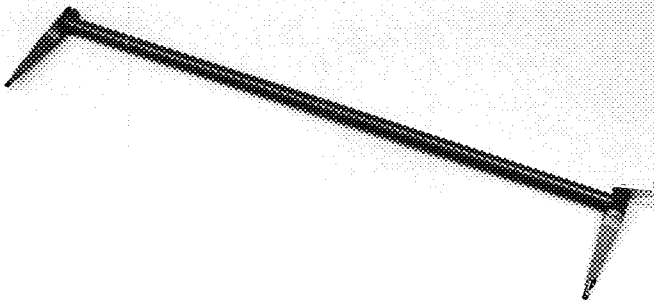
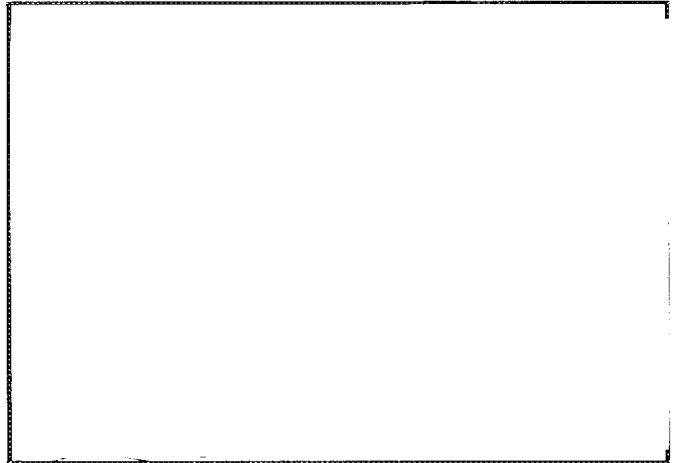

Foto 12

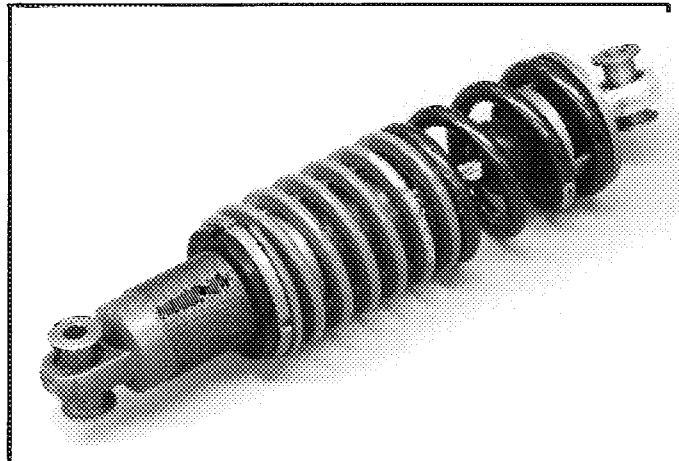

Foto 13

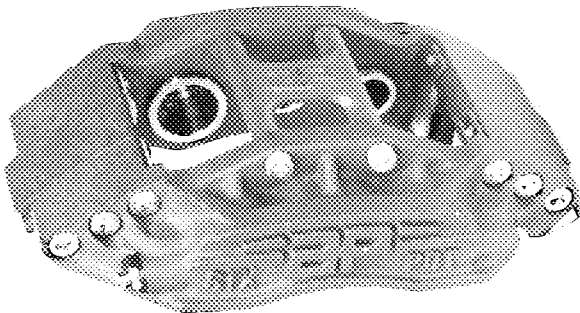

Marke BMW
Make

Modell M3
Model

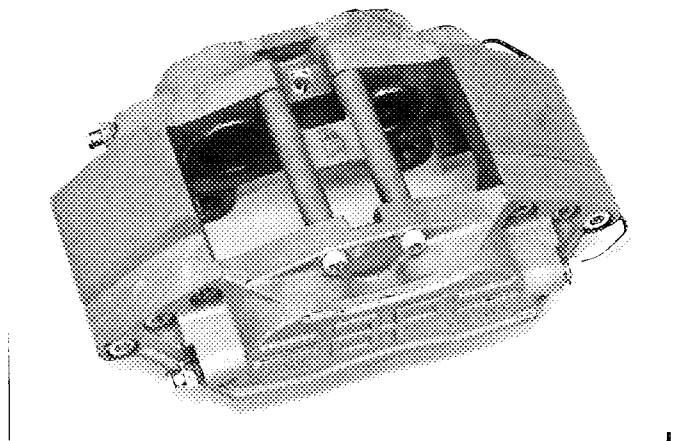
Homologations Nr. A 5327
Homologation Nr.

Fotos
Photos

Nachtrag Nr. 30 / 15 VO
Ext. Nr.

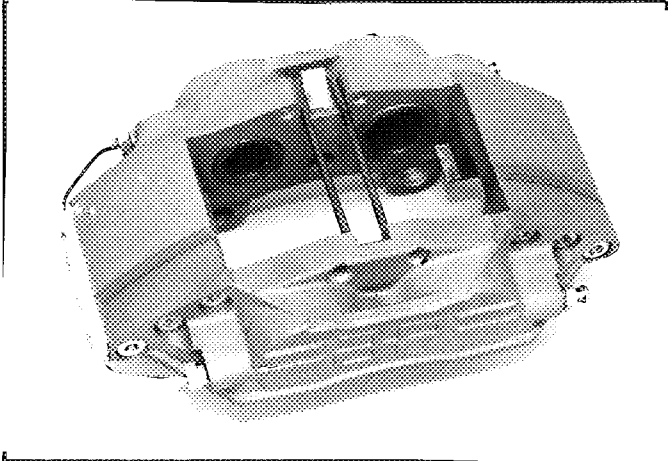

Foto

14

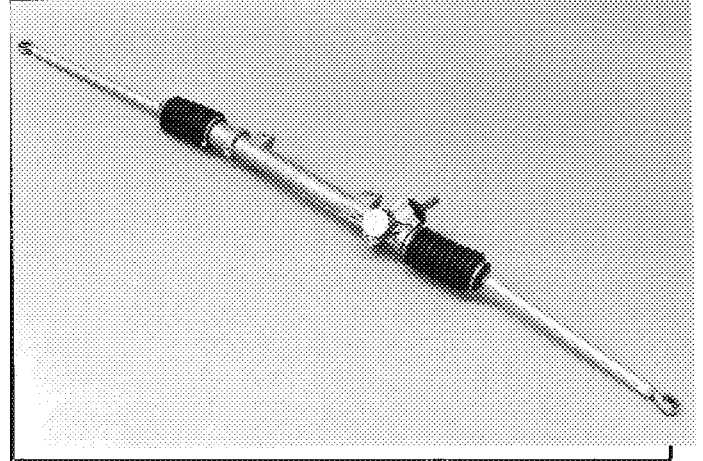

Foto

15



Foto

19

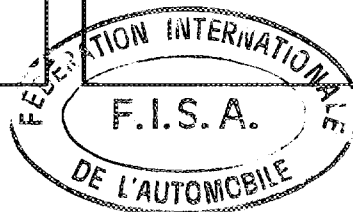
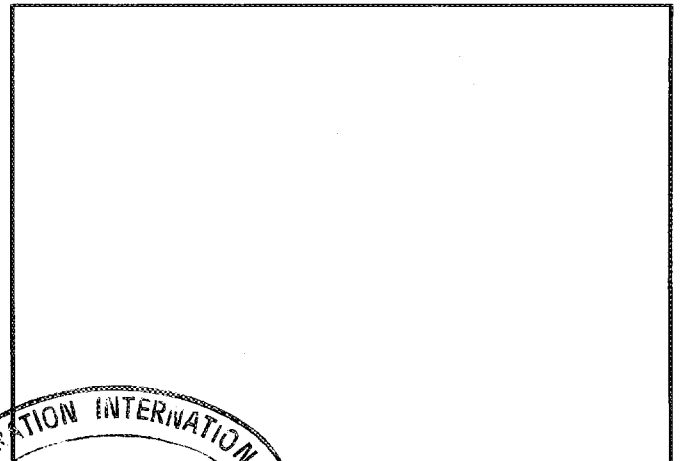

FÉDÉRATION INTERNATIONALE DU SPORT AUTOMOBILE

ONS Oberste Nationale Sportkommission für den Automobilsport in Deutschland GmbH

Homologation Nr.

A 5327

Nachtrag Nr.

Extension Nr.

31 / 05 VF

Nachtrag zum offiziellen Testblatt der FISA

Form of extension to the official FISA-Homologation

- ET** Normale Weiterentwicklung des Typs: ab Fahrgestell -Nr.: _____
Normal evolution of the type: as from chassis number:
- ES** Sportevolution
Sporting evolution
- VF** Liefervariante
Supply variant
- VO** Ausstattungsvariante
Option variant
- ER** Berichtigung
Erratum

Homologation gültig ab: 1. Januar 1990
Homologation valid as from

in Gruppe: A
in group

Hersteller: BMW Motorsport GmbH
Manufacturer

Modell und Typ: BMW M3
Model and type

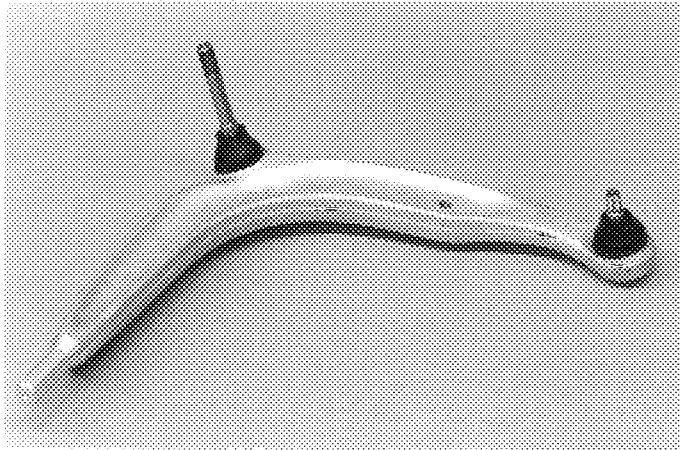
Seite od. Nachtrag Page or ext.	Artikel Art.	Beschreibung Description
Seite 7	701A	Querlenker / wishbone, Aluminium
		

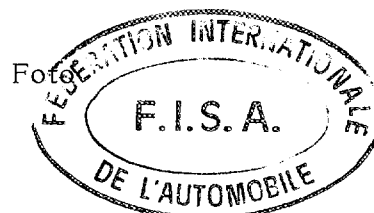

[Handwritten signature]

FÉDÉRATION INTERNATIONALE DU SPORT AUTOMOBILE

ONS Oberste Nationale Sportkommission für den Automobilsport in Deutschland GmbH

Homologation Nr.

A 5327

Nachtrag Nr.
Extension Nr.

32-02ES

Nachtrag zum offiziellen Testblatt der FISA

Form of extension to the official FISA-Homologation

- ET** Normale Weiterentwicklung des Typs: ab Fahrgestell -Nr.: _____
Normal evolution of the type, as from chassis number.
- ES** Sportevolution
Sporting evolution
- VF** Liefervariante
Supply variant
- VO** Ausstattungsvariante
Option variant
- ER** Berichtigung
Erratum

**NON VALABLE EN RALLYE /
NOT VALID FOR RALLIES**

Homologation gültig ab: 01.03.1990 in Gruppe: A
Homologation valid as from in group

Hersteller: BMW Motorsport GmbH Modell und Typ: BMW M3
Manufacturer: Model and type

Seite od. Nachtrag <small>Page or ext.</small>	Artikel <small>Art.</small>	Beschreibung <small>Description</small>
Seite 1	103	Foto / picture A + B + Zeichnungen / drawings 2466,7 cm ³
Seite 2	202 204A 204B 209A 209B	4363 mm +/- 1% 1662 mm +/- 1% 1661 mm +/- 1% 789,5 mm +/- 1% 1000 mm +/- 1%
Seite 3	314 315 316 319H 320B 324D 327D	95,0 mm 95,6 mm 87,0 mm 16380 g 5160 g 48 +/- 0,25 mm 38,5 mm

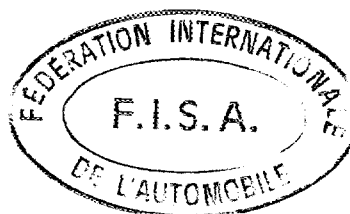

Marke BMW
Make

Modell M3
Model:

Homologations Nr. A 5327
Homologation Nr.

Nachtrag Nr. 32-02ES
Ext. Nr.

Seite od. Nachtrag Page or ext.	Artikel Art	Beschreibung Description
Seite 11		neues Foto / new picture C neues Foto / new picture D
Seite 12		neues Foto / new picture G neues Foto / new picture J
Seite 5	401A	1
	401B	unter der hinteren Sitzbank / under rear seat, outside
	401C	Stahlblech / sheet steel
	401D	62 l
Seite 8	801A	vorne und hinten / front and rear 16" = 406,4 mm

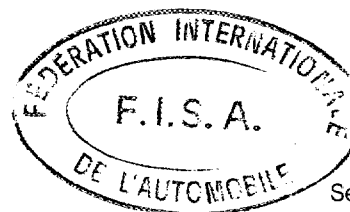

Marke BMW
Make

Modell M3
Model

Homologations Nr. A 5327
Homologation Nr.

Fotos
Photos

Nachtrag Nr. 32-02ES
Ext. Nr.



Foto A



Foto B



Foto C



Foto D

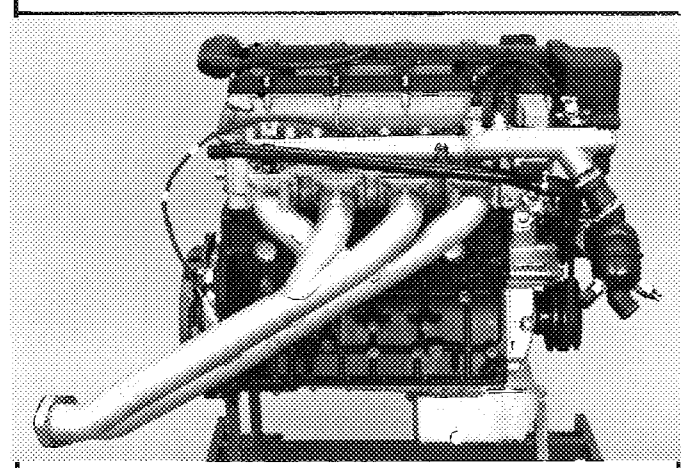

Foto F

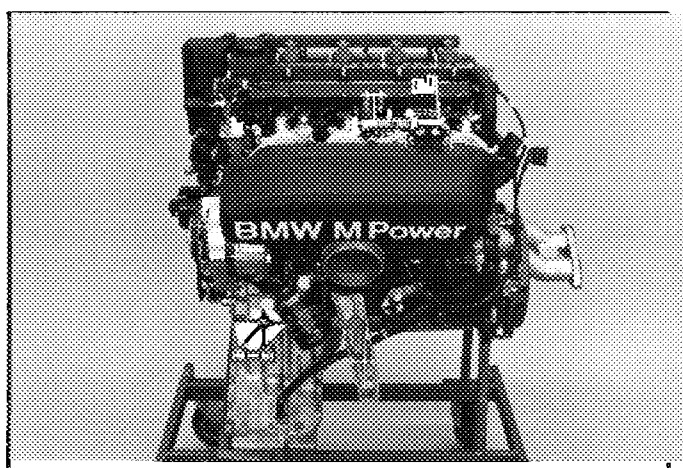

Foto G

Marke BMW
Make

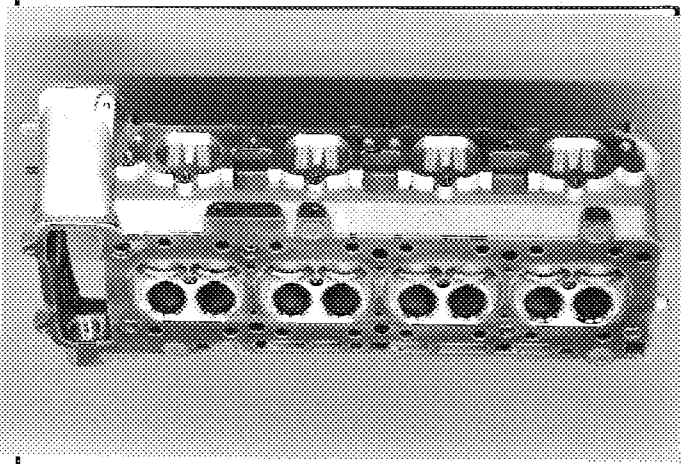
Modell M3
Model

Homologations Nr. A 5327
Homologation Nr.

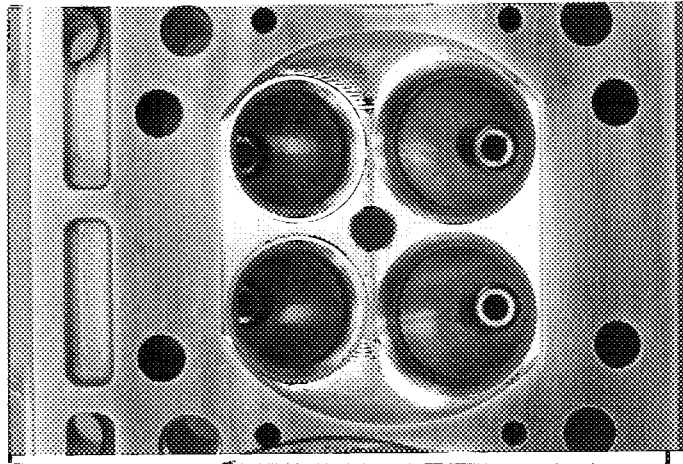
Fotos
Photos

Nachtrag Nr. 32-02ES
Ext. Nr.



Foto J

2 x Ø 50 mm

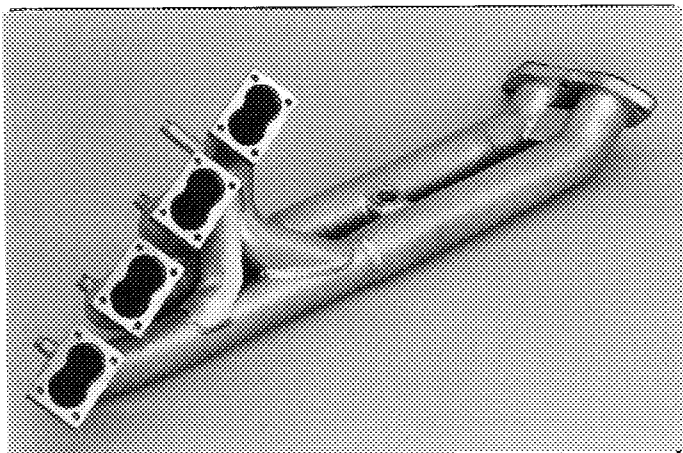
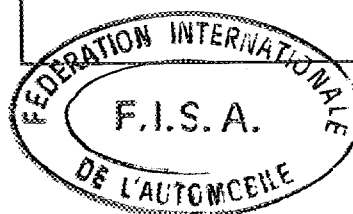
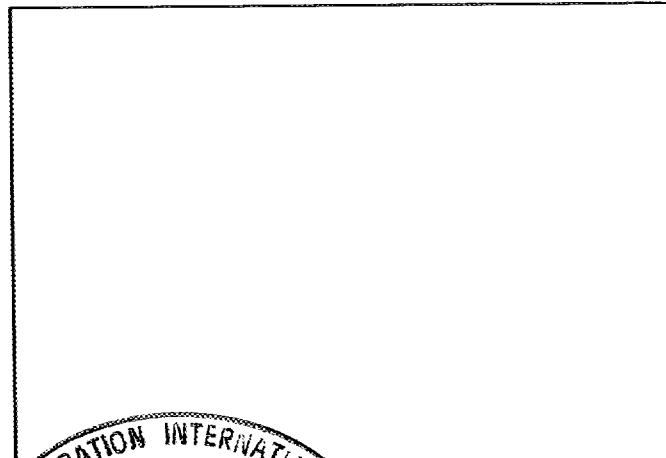
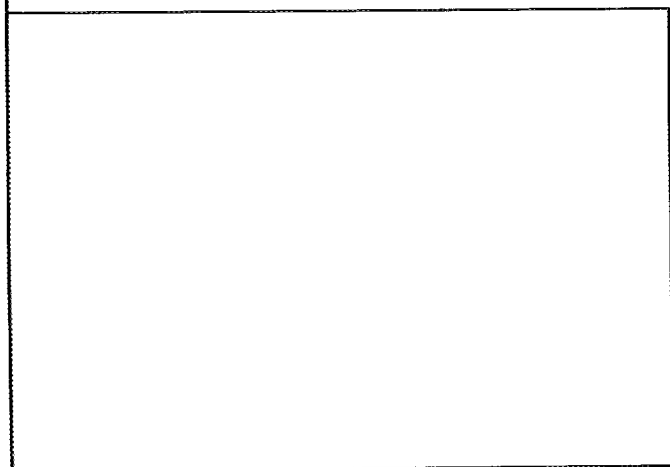
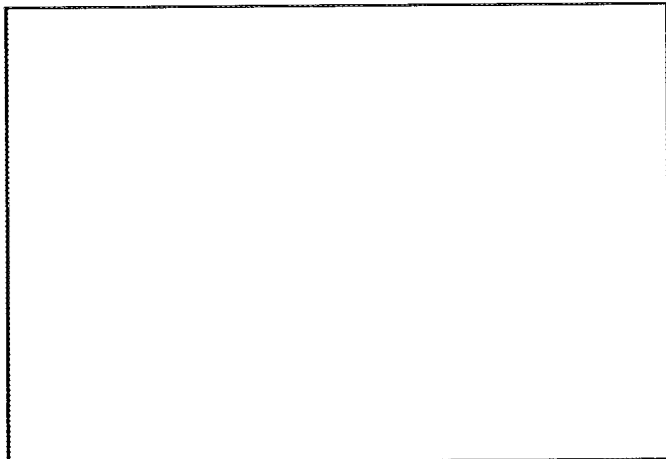
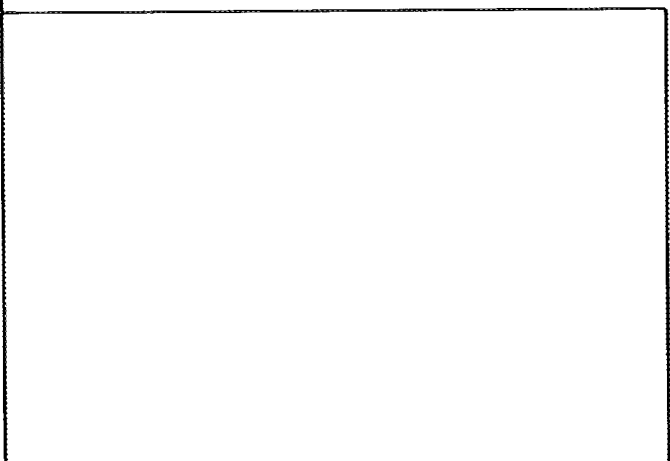
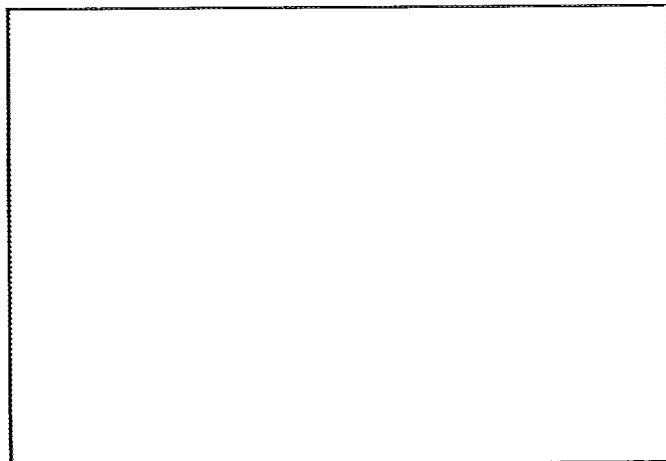

Marke BMW
Make

Modell M3
Model

Homologations Nr. A 5327
Homologation Nr.

32-02ES

Frontspoiler in 4 Positionen verstellbar /
- front spoiler in 4 positions adjustable

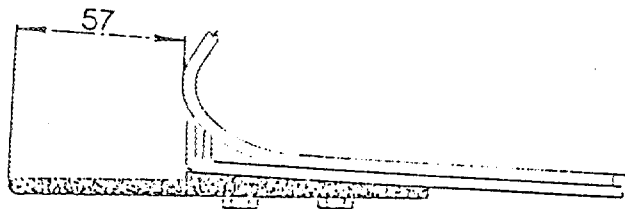
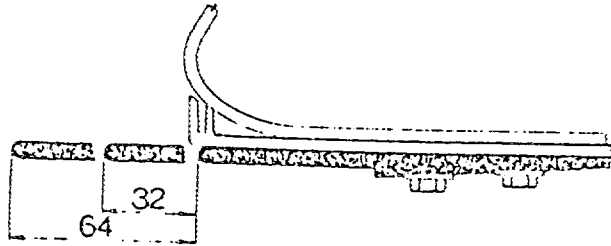

alle Maße +/- 2 mm
all dimensions +/- 2 mm

Heckspoiler in 4 Positionen verstellbar /
rear spoiler in 4 positions adjustable

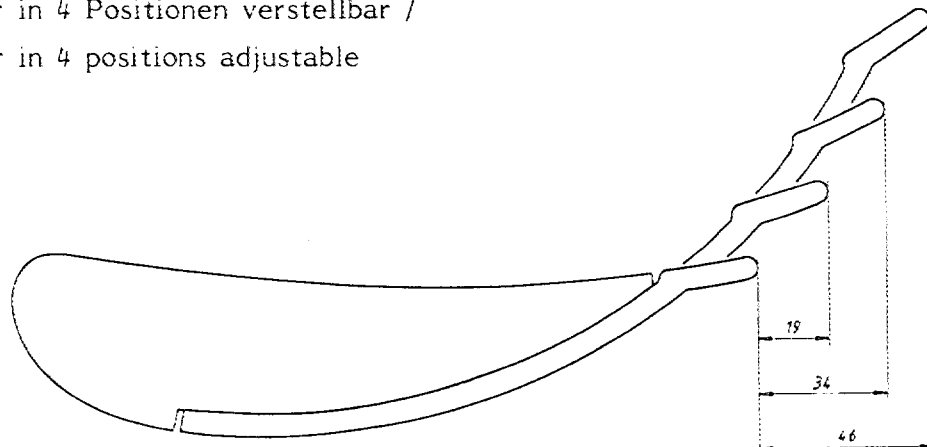

alle Maße +/- 2 mm
all dimensions +/- 2 mm

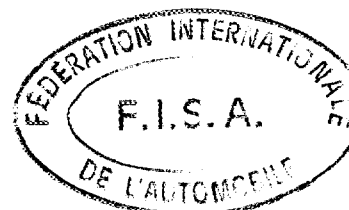

Nachtrag zum offiziellen Testblatt der FISA

Form of extension to the official FISA-Homologation

- ET** Normale Weiterentwicklung des Typs: ab Fahrgestell-Nr.: _____
Normal evolution of the type: as from chassis number:
- ES** Sportevolution
Sporting evolution
- VF** Liefervariante
Supply variant
- VO** Ausstattungsvariante
Option variant
- ER** Berichtigung
Erratum

Homologation gültig ab: 01.04.1990 in Gruppe: A
Homologation valid as from: in group

Hersteller: BMW Motorsport GmbH Modell und Typ: BMW M3
Manufacturer Model and type

Seite od. Nachtrag Page or ext.	Artikel Art.	Beschreibung Description	
Seite 7	701B	Verstärkter Schräglenker / reinforced semi training arm	Foto 2
	701A	Verstärkte Druckstrebenlager / reinforced bracket for pressure strut	Foto 3
	701A	Verstärkte Spurstange / reinforced steering tie rod	Foto 4
	701B	Verstärkter Stabilisator mit geänderter Befestigung / reinforced stabilizer with changed attachment	Foto 5

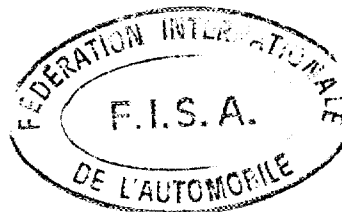

Seite od. Nachtrag Page or ext.	Artikei Art	Beschreibung Description	
Seite 8	803	Bremssattel vorne / brake caliper front	Foto 6
	803E	4 or 2/2 or 4 or 2/2	
	803E1	42,8 mm 40/45 mm 42,8 mm 40/45 mm	
	803G1	2 2 2 2	
	803G2	1 1 1 1	
	803G3	Aluminium Aluminium Aluminium Aluminium	
	803G8	128 +/- 1,5 mm	
	803	Bremssattel vorne / brake caliper front	Foto 7
	803E	2/2	
	803E1	40/45 mm	
	803G1	2	
	803G2	1	
	803G3	Aluminium	
	803G8	128 +/- 1,5 mm	
	803	Bremssattel hinten / brake caliper rear	Foto 8
	803E	4	
	803E1	33,9/38 mm	
	803G1	2	
	803G2	1	
	803G3	Aluminium	
	803G8	95 +/- 1,5 mm	
	803	Bremsscheiben, vorne / brake disks, front	Foto 9 + 10
	803G4	32/35 mm +/- 1,5 mm	
	803G5	355/332 mm +/- 1,5 mm	
	803G6	354/331 mm +/- 1,5 mm	
803G7	244/221/219/196 +/- 1,5 mm		
803G9	ja / yes		
803	Bremsscheibe, hinten / brake disk, rear	Foto 11	
803G4	22,2 mm +/- 1,5 mm		
803G5	280 +/- 1,5 mm		
803G6	279 +/- 1,5 mm		
803G7	179 +/- 1,5 mm		
803G9	ja / yes		

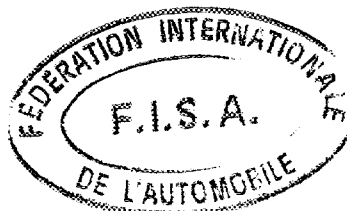

Marke
Make

BMW

Modell
Model

M3

Homologations Nr.
Homologation Nr.

A-5327

Nachtrag Nr.
Ext. Nr.

33 / 10 M

Seite od. Nachtrag Page or ext.	Artikel Art.	Beschreibung Description	
Seite 8	803	Bremsscheiben vorne, glatt und/oder genutet und/oder gelocht / brake disks, front, plain and/or grooved and/or drilled	Foto 12
	803G4	32/35 +/- 1,5 mm	
	803G5	332/343/348/355 +/- 1,5 mm	
	803G6	332/343/348/355 +/- 1,5 mm	
	803G7	224/235/240/247 +/- 1,5 mm	
	803G8	152 +/- 1,5 mm	
	803G9	ja / yes Kühlkanal 15,8 mm oder 21,0 mm +/- 1,5 mm / air gap 15,8 or 21,0 +/- 1,5 mm	
	803	Bremsscheibe hinten, glatt und/oder genutet und/oder gelocht / brake disk, rear, plain and/or grooved and/or drilled	Foto 13
	803G4	25,4 +/- 1,5 mm	
	803G5	304 +/- 1,5 mm	
	803G6	304 +/- 1,5 mm	
	803G7	204/209 +/- 1,5 mm	
	803G9	ja / yes Kühlkanal 12,7 mm oder 15,8 mm +/- 1,5 mm / air gap 12,7 or 15,8 +/- 1,5 mm	
	803	Belüftung Bremsscheibe, hinten / rear brake disk ventilation Querschnittsfläche / cross section 78,4 cm ²	Foto 14
Nachtrag 30/15 VO Foto 13 + Foto 14		Zusätzlich / additional	
	803G6	304 +/- 1,5 mm	
	803G7	209 +/- 1,5 mm	
	803	Bremsscheibentopf / brake disk mounting bell	Foto 15
	803	Halter für Bremssattel vorne / bracket for front brake caliper	Foto 16

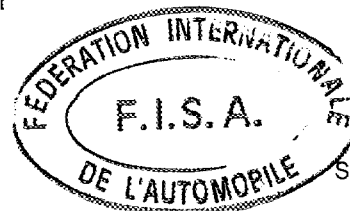

Marke BMW
Make

Modell M3
Model

Homologations Nr. A-5327
Homologation Nr.

Fotos
Photos

Nachtrag Nr. 33 / 18 V0
Ext. Nr.



Foto 2



Foto 3

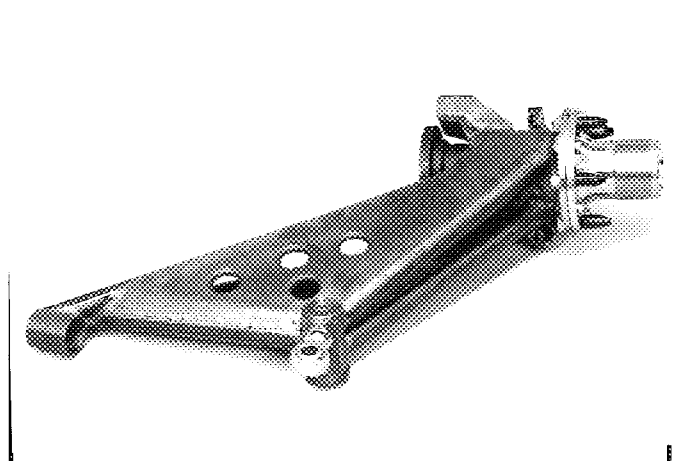
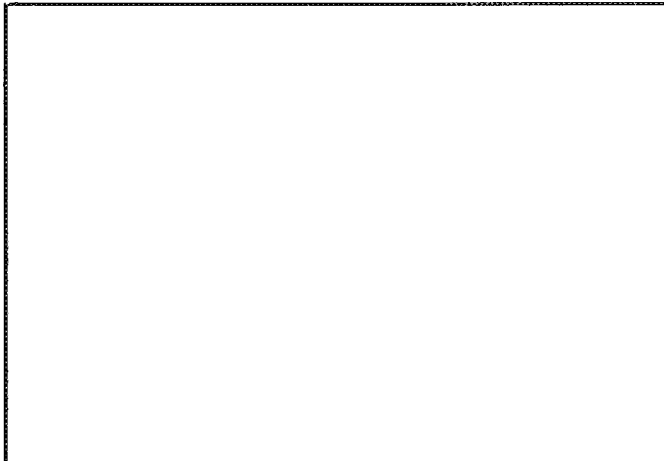

Foto 4

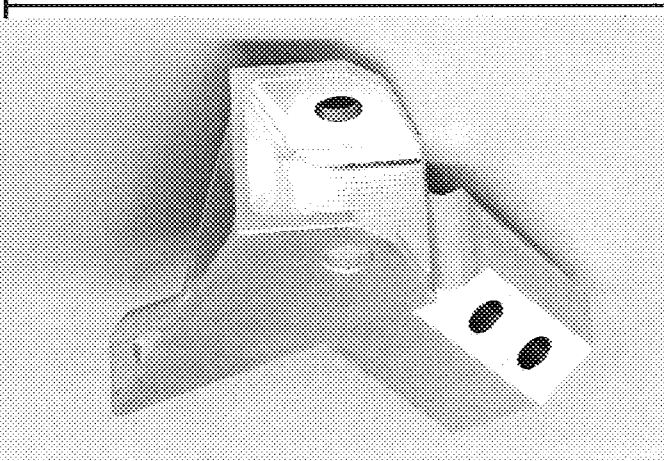

Foto 5

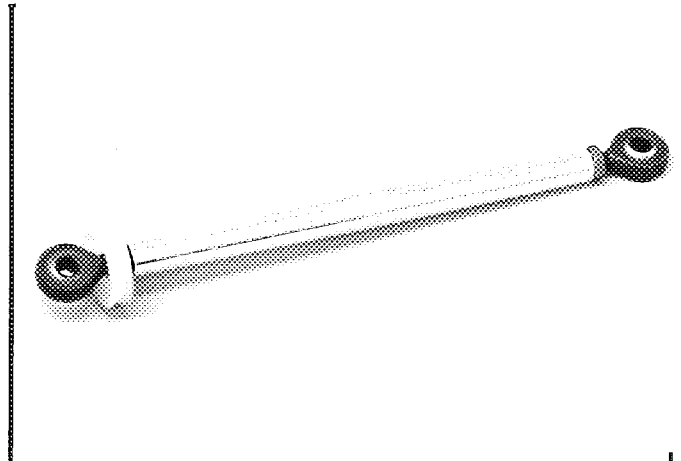

Foto

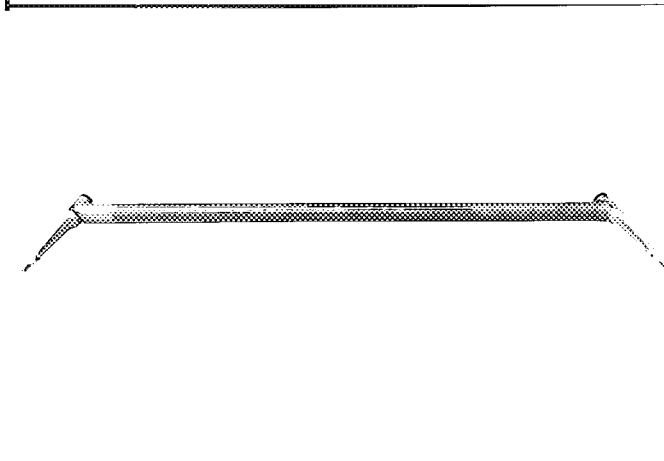
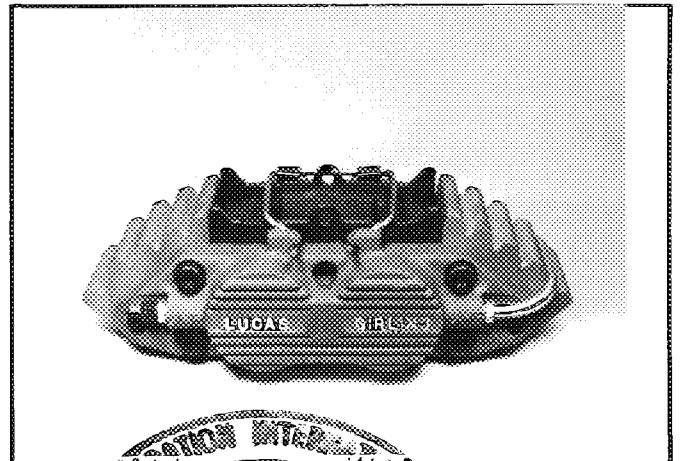

Marke BMW
Make

Modell M3
Model

Homologations Nr. A-5327
Homologation Nr.

Fotos
Photos

33 / 18 W
Nachtrag Nr. _____
Ext. Nr.



Foto 7



Foto 8

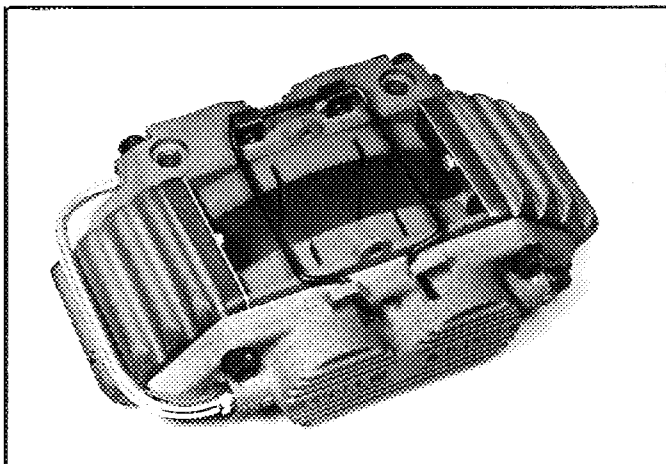

Foto 9

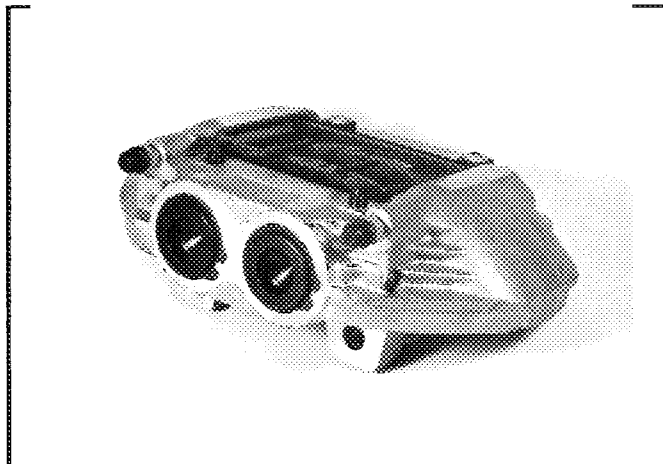

Foto 10

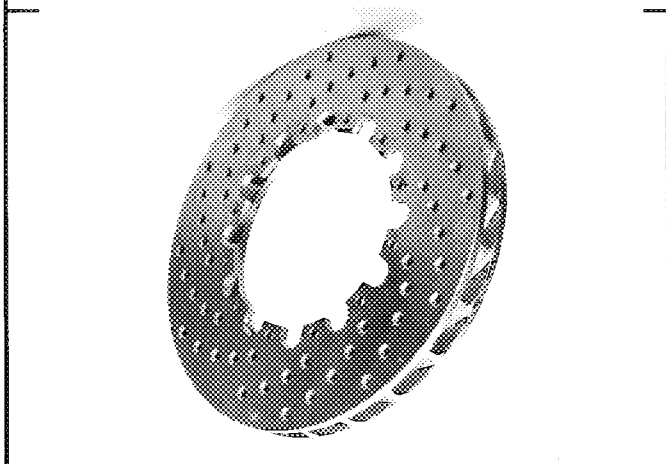

Foto 11

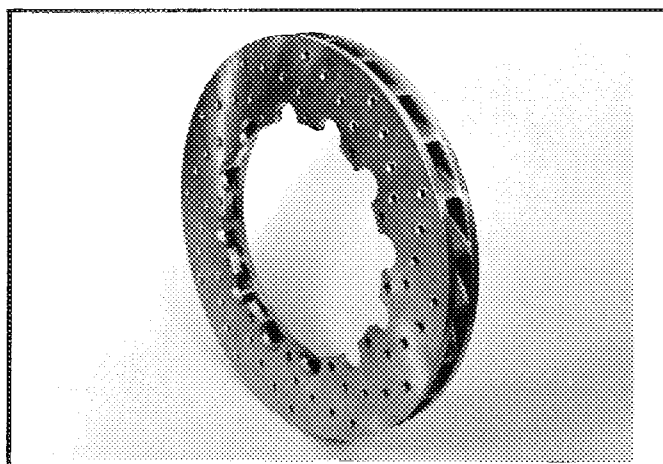

Foto 12

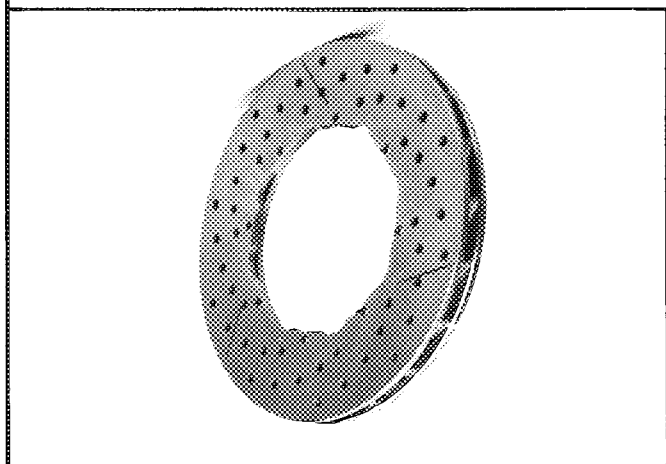

Marke BMW
Make

Modell M3
Model

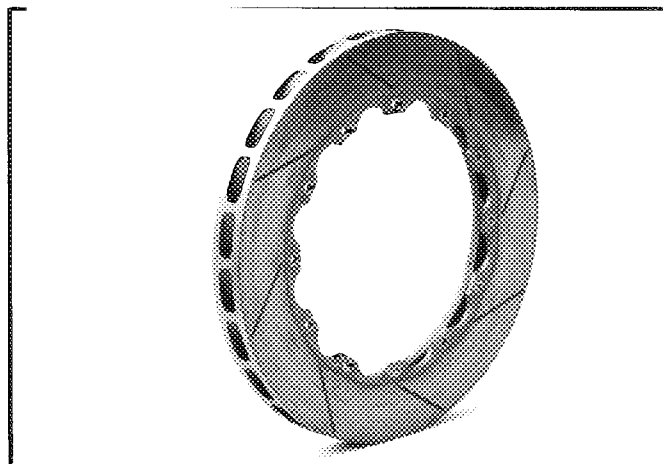
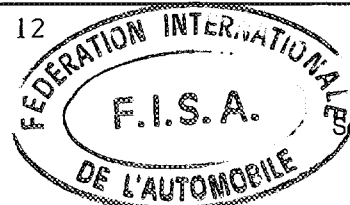
Homologations Nr. A-5327
Homologation Nr.

Fotos
Photos

Nachtrag Nr. 33 / 10 m
Ext. Nr.



Foto 13



Foto 14

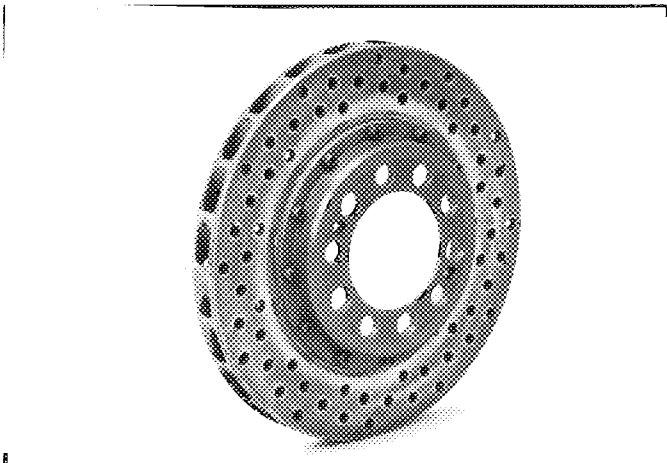

Foto 15

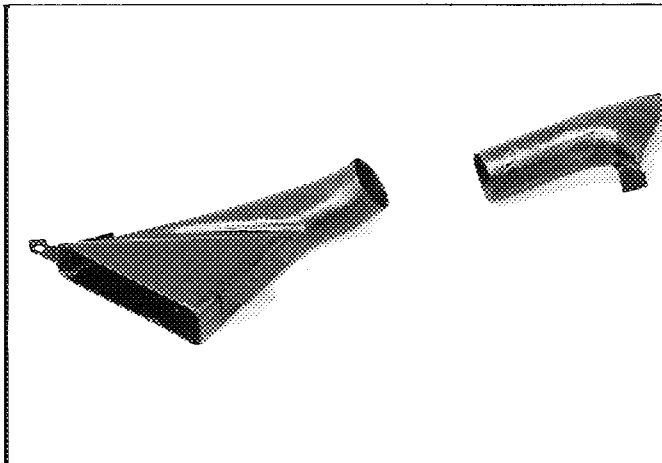

Foto 16

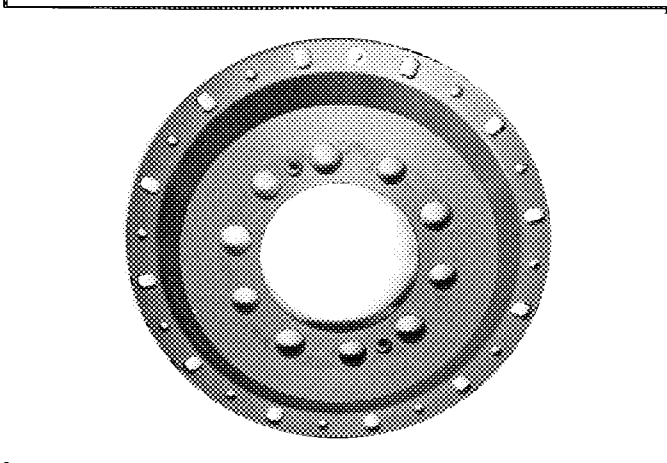

FÉDÉRATION INTERNATIONALE DU SPORT AUTOMOBILE
ONS Oberste Nationale Sportkommission für den Automobilsport in Deutschland GmbH

Homologation Nr.

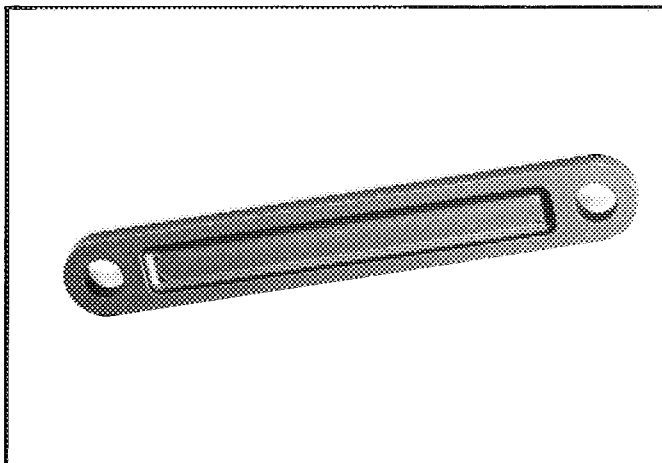
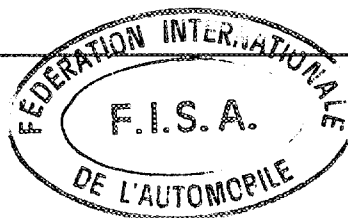
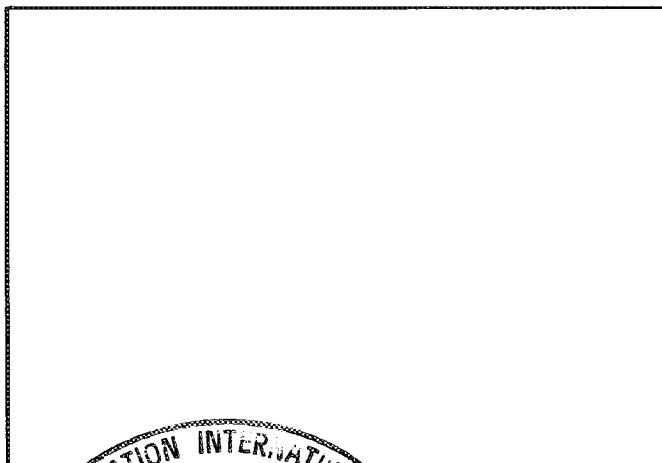
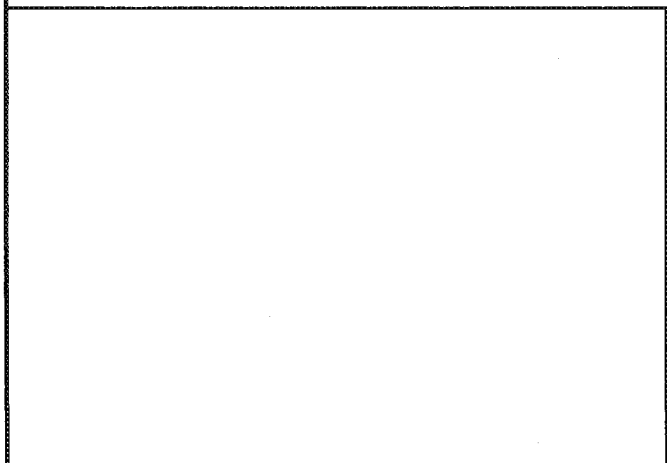
A-5327

Nachtrag Nr.
Extension Nr.

34 / 10 ER

Nachtrag zum offiziellen Testblatt der FISA

Form of extension to the official FISA-Homologation

- ET** Normale Weiterentwicklung des Typs; ab Fahrgestell -Nr.: _____
Normal evolution of the type, as from chassis number:
- ES** Sportevolution
Sporting evolution
- VF** Liefervariante
Supply variant
- VO** Ausstattungsvariante
Option variant
- ER** Berichtigung
Erratum

Homologation gültig ab: 01 MAI 1990 in Gruppe: A
 Homologation valid as from: _____ in group: _____

Hersteller: BMW Motorsport GmbH Modell und Typ: BMW M3
 Manufacturer: _____ Model and type: _____

Seite od. Nachtrag Page or ext.	Artikel Art.	Beschreibung Description
Seite/ page 5	401D	79 l anstelle 70 l 79 l instead of 70 l

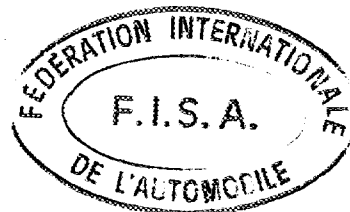

[Handwritten signature]

FÉDÉRATION INTERNATIONALE DU SPORT AUTOMOBILE

ONS Oberste Nationale Sportkommission für den Automobilsport in Deutschland GmbH

Homologation Nr.

A 5327

Nachtrag Nr.
Extension Nr.

35 / 17 VO

Nachtrag zum offiziellen Testblatt der FISA

Form of extension to the official FISA-Homologation

- ET** Normale Weiterentwicklung des Typs: ab Fahrgestell-Nr.: _____
Normal evolution of the type: as from chassis number:
- ES** Sportevolution
Sporting evolution
- VF** Liefervariante
Supply variant
- VO** Ausstattungsvariante
Option variant
- ER** Berichtigung
Erratum

Homologation gültig ab: 1. Juli 1990 in Gruppe: A
Homologation valid as from: _____ in group: _____

Hersteller: BMW Motorsport GmbH Modell und Typ: BMW M3
Manufacturer: _____ Model and type: _____

Seite od. Nachtrag Page or ext.	Artikel Art.	Beschreibung Description	
Seite page 7	701A	verstärktes Federbein / reinforced wheel upright	Foto 1
	701A	verstärkter Spurstangenhebel / reinforced steering arm	Foto 2
	701A	verstärkte Spurstange / reinforced tie rod	Foto 3
	701B	verstärkte Hinterradaufhängung / reinforced rear suspension	Foto 4
Seite page 9	804A	verstärktes Lenkgetriebe / reinforced steering	Foto 5
Nachtrag / Extension		30/15 VO Foto 12 zusätzlich / additional	Foto 6
	803	zusätzlich für alle Bremscheiben mit Außen- durchmesser / additional for all brake disks with outer diameter : 343 mm 348 mm 355 mm +/- 1,5 mm	
	803G7	zusätzlich / additional : 224 mm 235 mm 247 mm 251 mm 256 mm 263 mm +/- 1,5 mm	
Nachtrag / Extension		33/16 VO 803G7 Foto 13 zusätzlich / additional Bremscheiben / brake disks 251 mm 256 mm 263 mm +/- 1,5 mm	Foto 7 + 8

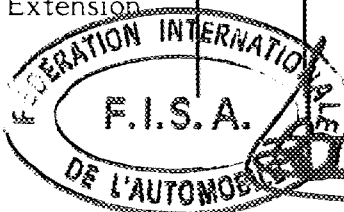

Marke BMW
Make

Modell M3
Model

Homologations Nr. A 5327
Homologation Nr.

35 / 17 V0

Nachtrag Nr. _____
Ext. Nr.

Seite od. Nachtrag Page or ext.	Artikel Art	Beschreibung Description
Seite page 6	603D	verstärkte Schaltkonsole / reinforced gear change

Foto 9

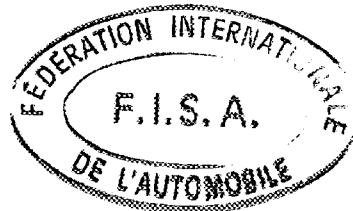

Marke BMW
Make

Modell M3
Model

Homologations Nr. A 5327
Homologation Nr.

Fotos
Photos

Nachtrag Nr. 35 / 17 V0
Ext. Nr.



Foto 1



Foto 2

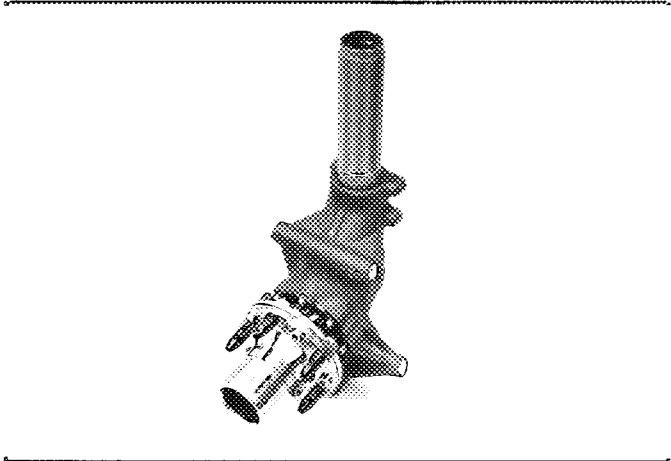

Foto 3

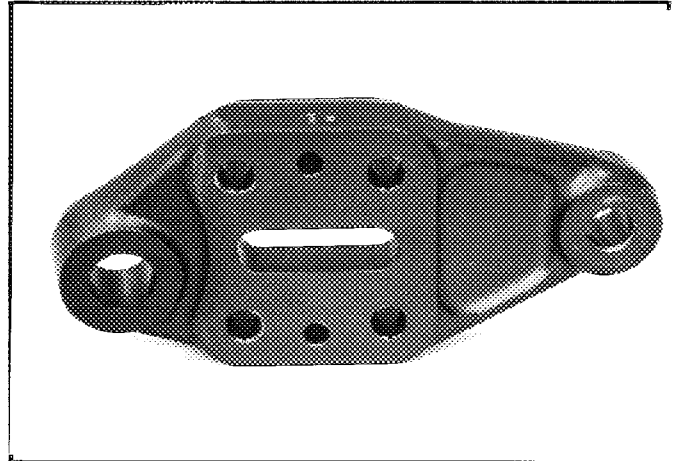

Foto 4

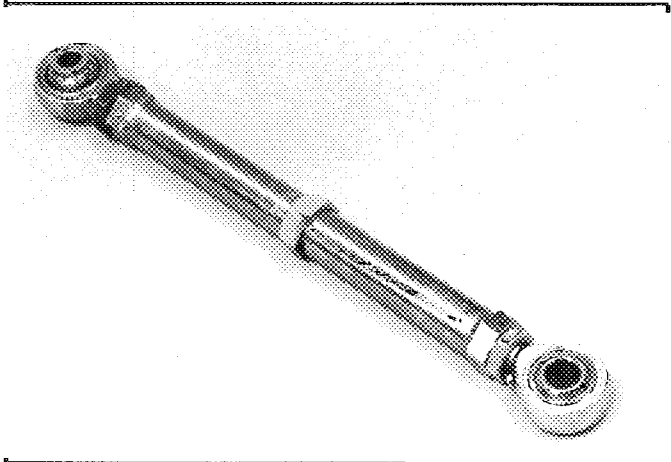

Foto 5

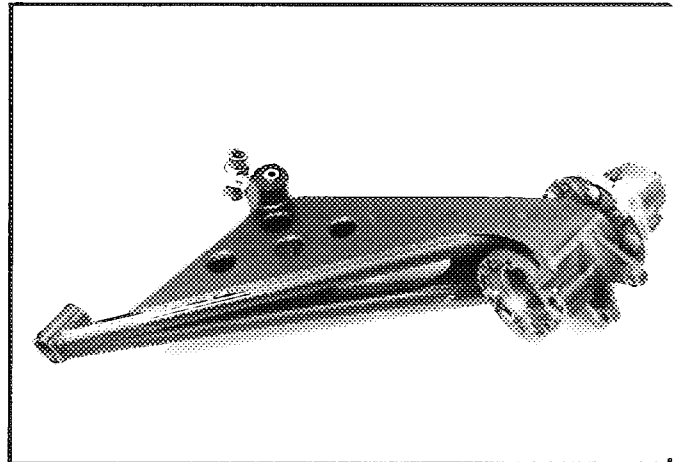

Foto 6

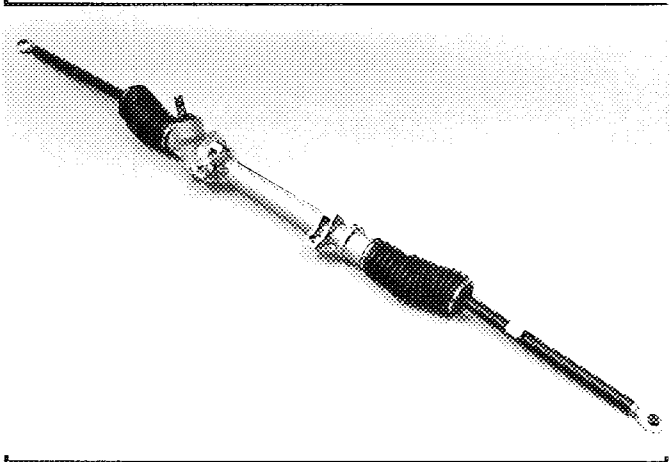

Marke BMW
Make

Modell M3
Model

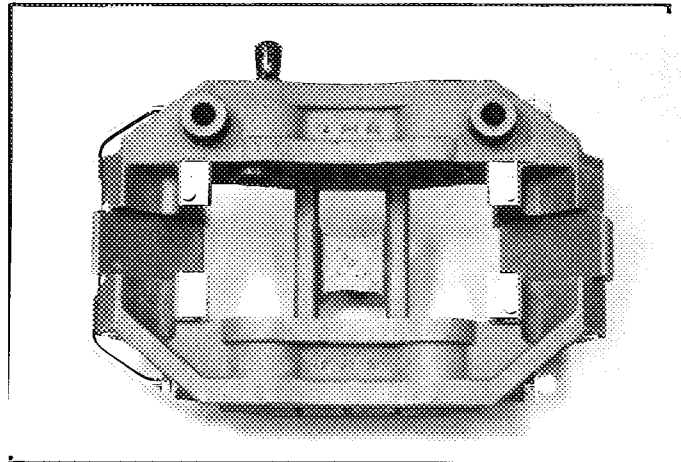
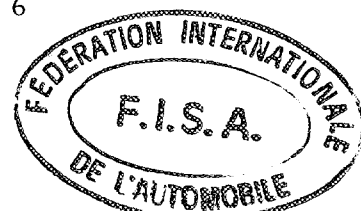
Homologations Nr. A 5327
Homologation Nr.

Fotos
Photos

Nachtrag Nr. 35 / 17 V0
Ext. Nr.



Foto 7



Foto 8

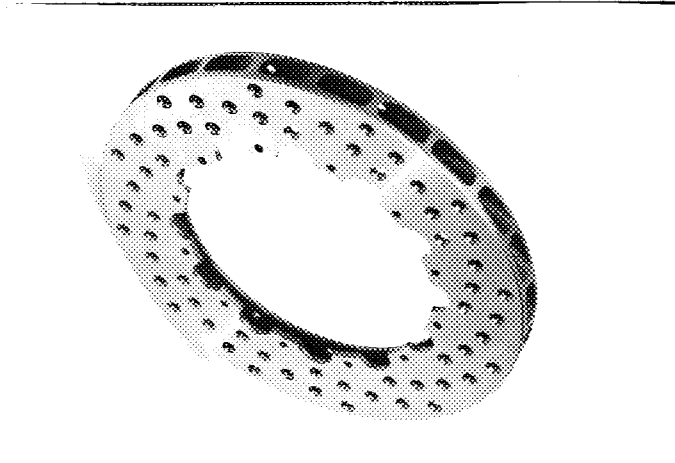

Foto 9

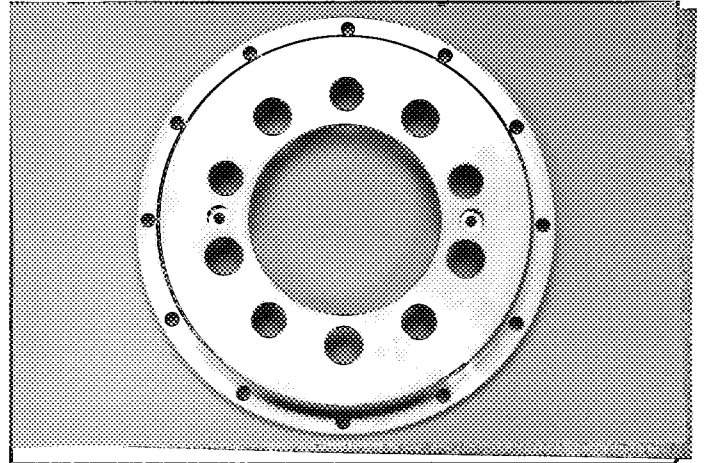

FÉDÉRATION INTERNATIONALE DU SPORT AUTOMOBILE

ONS Oberste Nationale Sportkommission für den Automobilsport in Deutschland GmbH

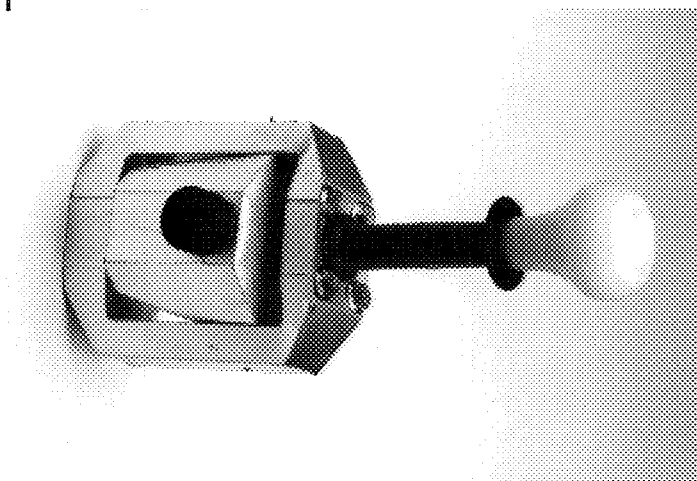
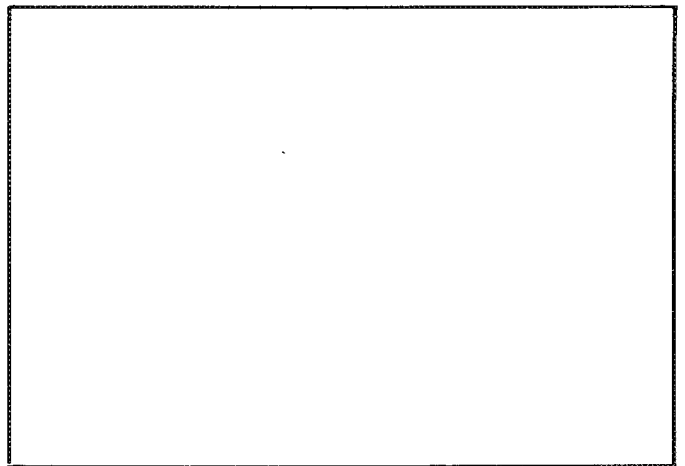
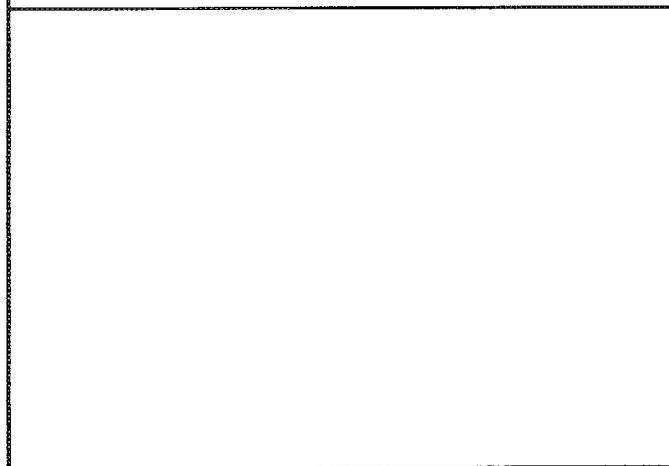
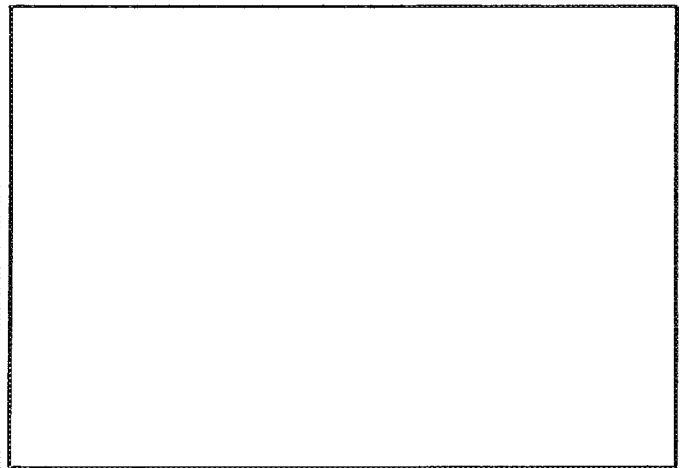
Homologation Nr.

A-5327

Nachtrag Nr.
Extension Nr.

36 / 18 VO

Nachtrag zum offiziellen Testblatt der FISA

Form of extension to the official FISA-Homologation

- ET** Normale Weiterentwicklung des Typs: ab Fahrgestell-Nr.: _____
Normal evolution of the type, as from chassis number
- ES** Sportevolution
Sporting evolution
- VF** Liefervariante
Supply variant
- VO** Ausstattungsvariante
Option variant
- ER** Berichtigung
Erratum

Homologation gültig ab: 01.04.1991 in Gruppe: A
Homologation valid as from: _____ in group: _____

Hersteller: BMW Motorsport GmbH Modell und Typ: BMW M3
Manufacturer: _____ Model and type: _____

Seite od. Nachtrag Page or ext.	Artikel Art.	Beschreibung Description	
Seite 5	602B	Hydraulische Kupplungsbetätigung - Hydraulic clutch control	Foto 1
Seite 7	701A	Verstärktes Federbein - Reinforced front suspension	Foto 2
	701B	Verstärkte Schräglenker - Reinforced rear suspension	Foto 3
Nachtr. 33/16 VO Foto 12	803	Bremsscheibe, vorne - Brake disk, front Zusätzliches Foto - Additional picture	Foto 4
Seite 9	803	Bremsscheibe hinten glatt und/oder genutzt und/oder gelocht - Brake disk rear plain and/or grooved and/or drilled	Foto 5
	803g4	25,4 ± 1,5 mm	
	803g5	280 ± 1,5 mm	
	803g7	185 ± 1,5 mm	

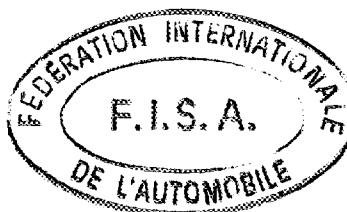

Marke BMW
Make

Modell M3
Model

Homologations Nr. A-5327
Homologation Nr.

Nachtrag Nr. 36 / 18 V0
Ext. Nr.

Seite od. Nachtrag Page or ext.	Artikel Art.	Beschreibung Description:	
Seite 8	803d1	Bremskraftregler im Fahrgastraum - Braking adjuster in passenger compart- ment	Foto 6
Seite 9	804	Verstärktes Lenkgetriebe - Reinforced steering box	Foto 7
		Verstärkte Lenkspindel - Reinforced steering spindle	Foto 8

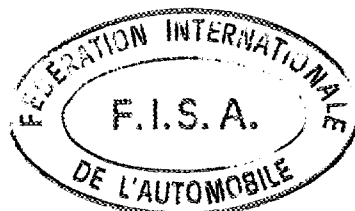

Marke BMW
Make

Modell M3
Model

Homologations Nr. A-5327
Homologation Nr.

Fotos
Photos

Nachtrag Nr. 36 / 18 V0
Ext. Nr.

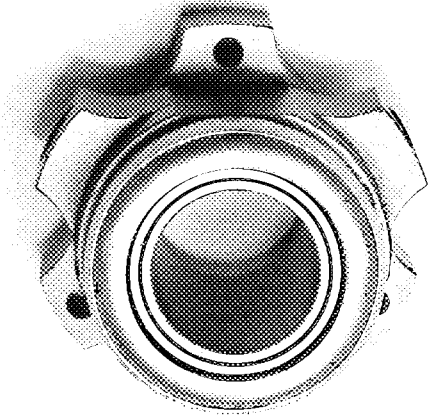

1

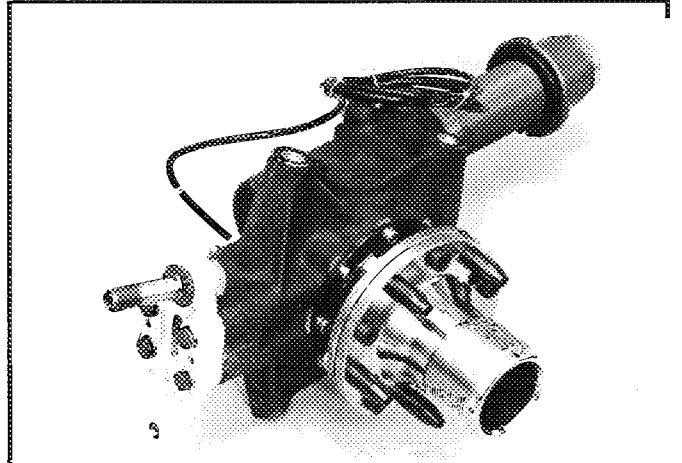

2

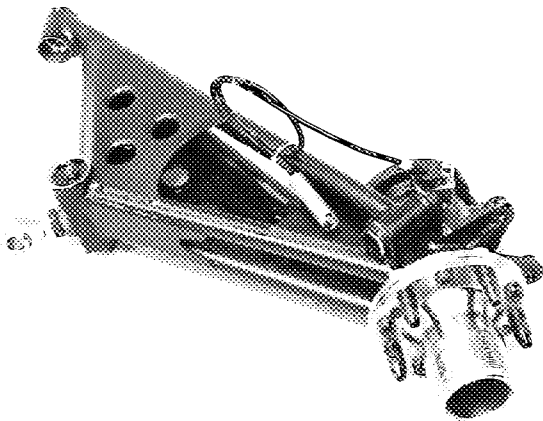

3

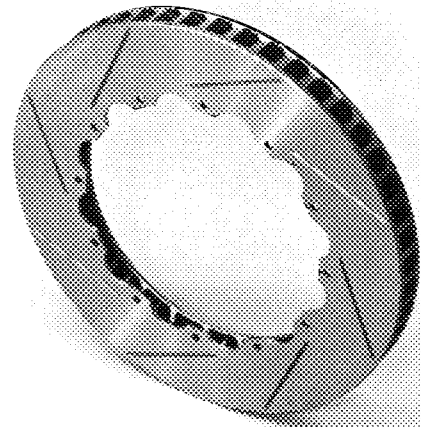

4

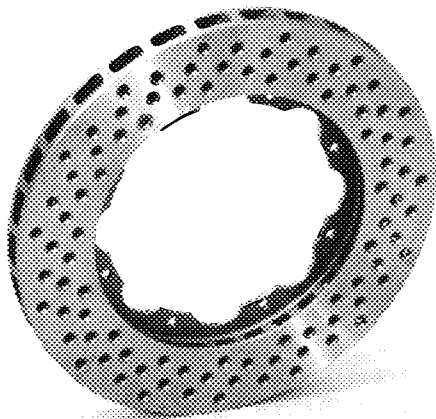

5

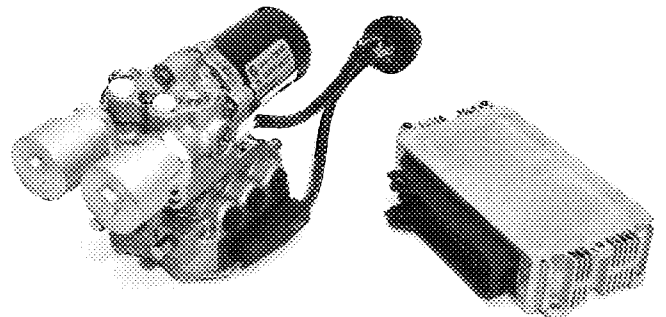

6



Marke BMW
Make

Modell M3
Model

Homologations Nr. A-5327
Homologation Nr.

36 / 18 V0

Fotos
Photos

Nachtrag Nr. _____
Ext. Nr.

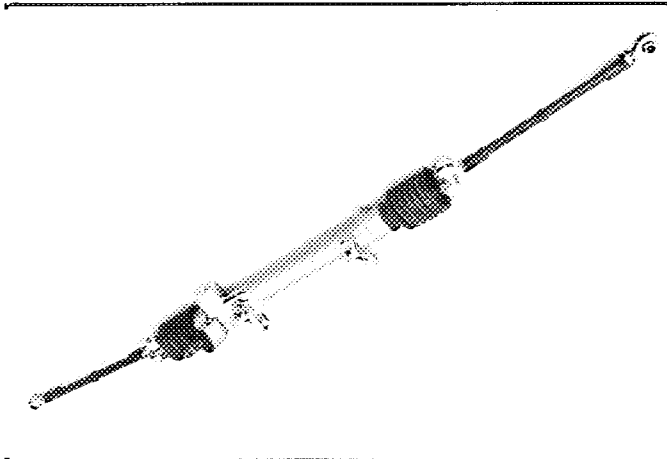

7

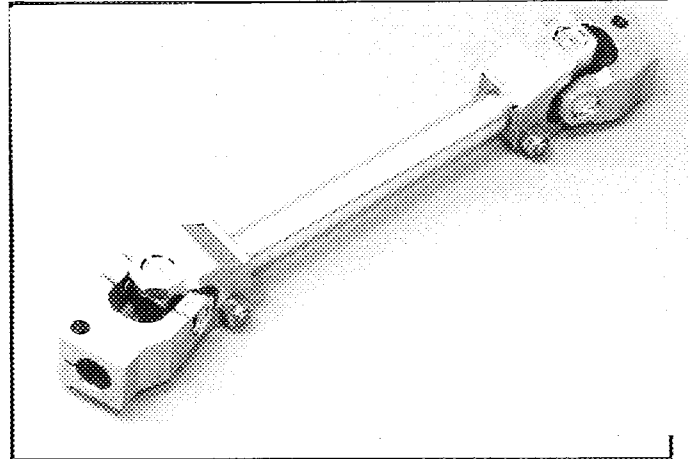

8

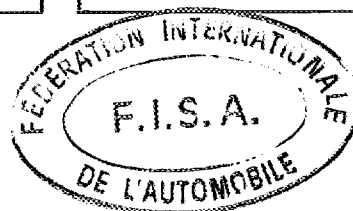
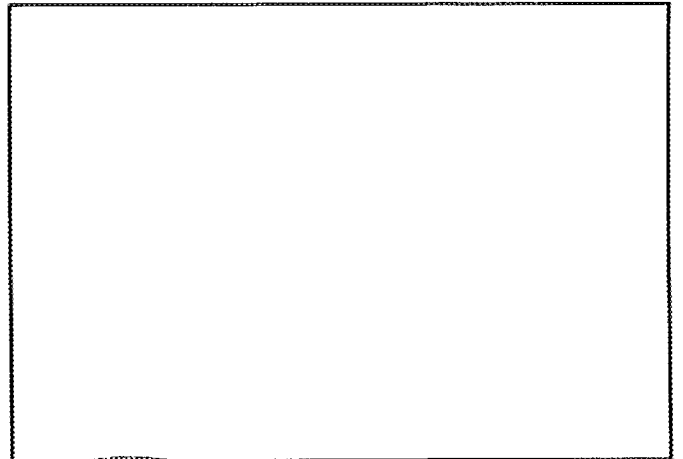
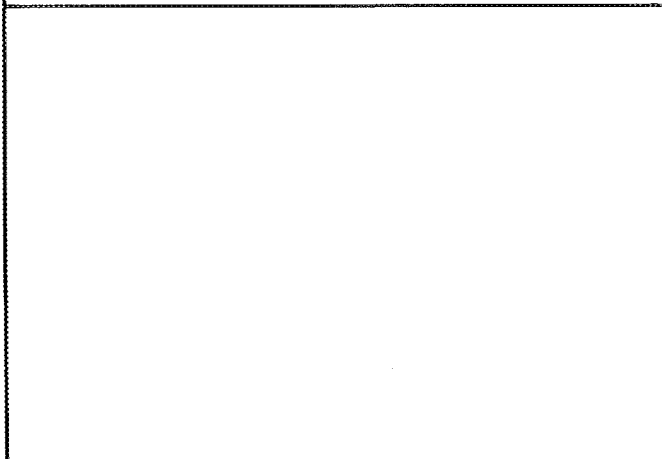
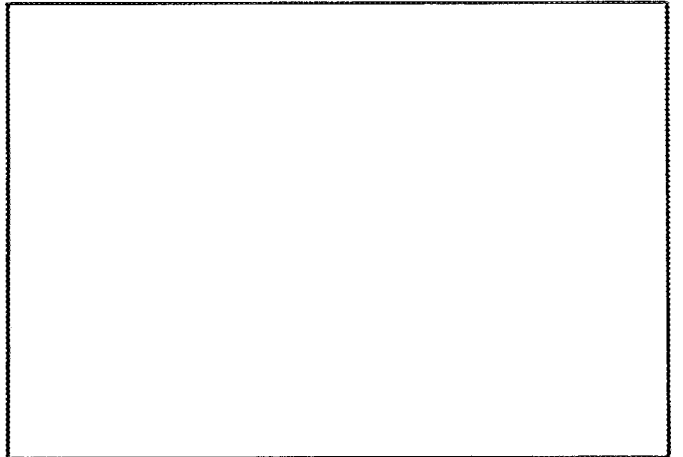
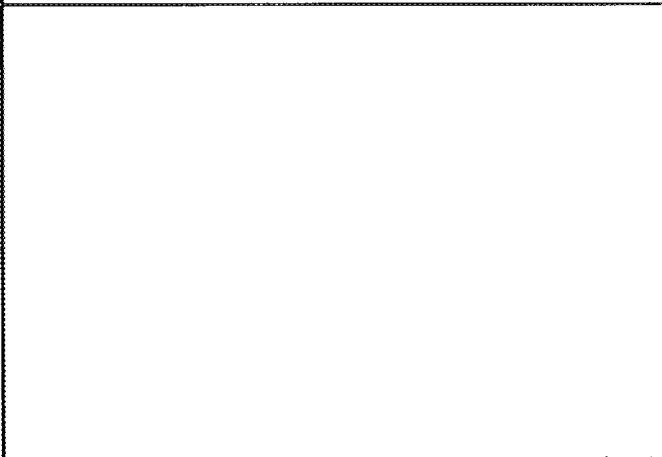

Nachtrag zum offiziellen Testblatt der FISA

Form of extension to the official FISA-Homologation:

- ET** Normale Weiterentwicklung des Typs: ab Fahrgestell-Nr.: _____
Normal evolution of the type: as from chassis number:
- VF** Liefervariante
Supply variant
- VO** Ausstattungsvariante
Option variant
- ER** Berichtigung
Erratum

Homologation gültig ab: 01.07.91 in Gruppe: A
Homologation valid as from: _____ in group: _____

Hersteller: BMW Motorsport GmbH Modell und Typ: BMW M3
Manufacturer: _____ Model and type: _____

Seite od. Nachtrag Page or ext.	Artikel Art.	Beschreibung Description	
Seite 7	701A	Verstärktes Federbein Reinforced front suspension	Foto 1
Seite 8	803A	Hydraulikeinheit für ABS Hydraulic unit for ABS	Foto 2



Foto 1





Foto 2

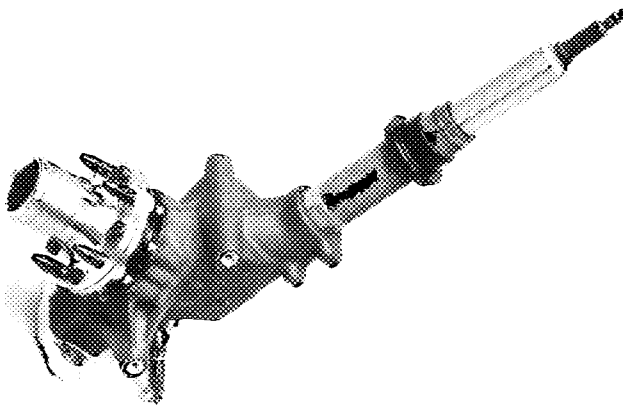

Seite (Page) 1/

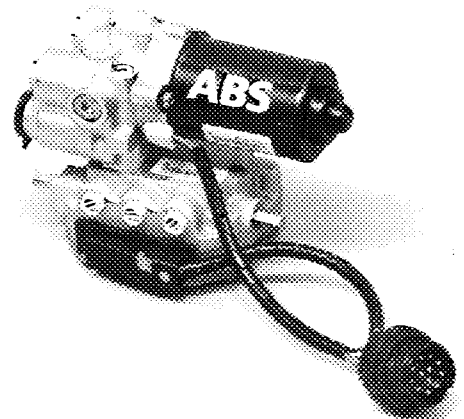
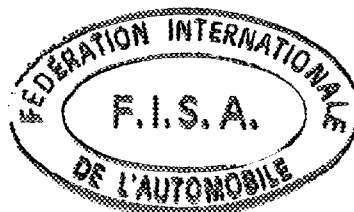
FÉDÉRATION INTERNATIONALE DU SPORT AUTOMOBILE
ONS Oberste Nationale Sportkommission für den Automobilsport in Deutschland GmbH

Homologation Nr.

A 5327

Nachtrag Nr.
Extension Nr.

38 / 20 VO

Nachtrag zum offiziellen Testblatt der FISA

Form of extension to the official FISA-Homologation

- ET** Normale Weiterentwicklung des Typs: ab Fahrgestell -Nr.: _____
Normal evolution of the type, as from chassis number.
- ES** Sportevolution
Sporting evolution
- VF** Liefervariante
Supply variant
- VO** Ausstattungsvariante
Option variant
- ER** Berichtigung
Erratum

01 NOV. 1991

Homologation gültig ab: _____ in Gruppe: A
Homologation valid as from: _____ in group

Hersteller: BMW Motorsport GmbH Modell und Typ: BMW M3
Manufacturer: _____ Model and type: _____

Seite od. Nachtrag Page or ext.	Artikel Art.	Beschreibung Description	
Seite 6	603 B	HOLINGER	Foto 1
	603 E	1. 3,064 - 33 : 14 2. 2,218 - 29 : 17 3. 1,671 - 27 : 21 4. 1,357 - 24 : 23 5. 1,144 - 22 : 25 6. 1,00 - ----- R. 3,064 - 33 : 14 Const. 1,300 - 26 : 20	
Seite 7	606	Verstärkte Gelenkwelle / reinforced shaft	Foto 2
	701 A	Verstärktes Federbein / reinforced suspension	Foto 3
	701 B	Verstärkte Schräglenker / reinforced trailing arm	Foto 4
Seite 9	804	Verstärkte Lenkung / reinforced steering	Foto 5
		Verstärkte Spurstange / reinforced steering arm	Foto 6
		Verstärkte Lenkverbindung / reinforced steering bracket	Foto 7

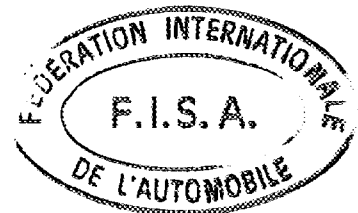

[Handwritten signature]

Fotos
Photos

Nachtrag Nr. 38 / 20 VO
Ext. Nr.



Foto 1



Foto 2

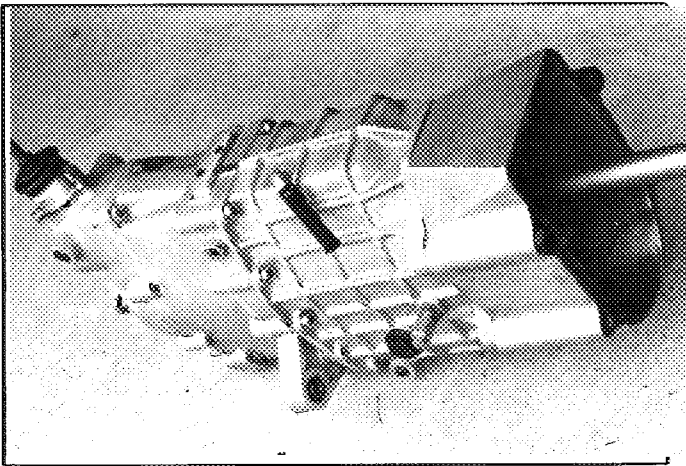

Foto 3

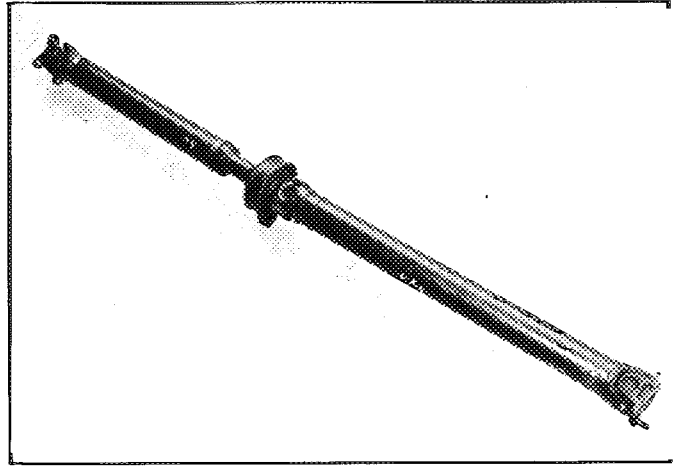

Foto 4

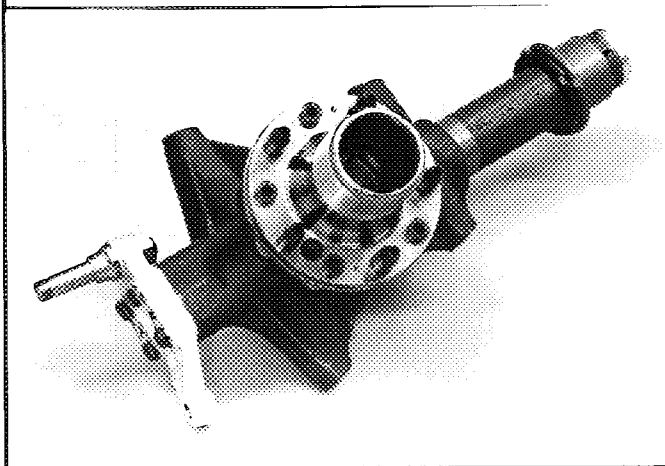

Foto 5

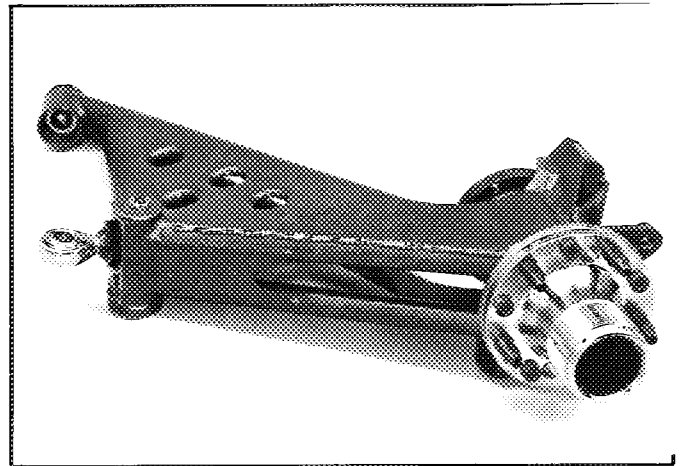

Foto 6

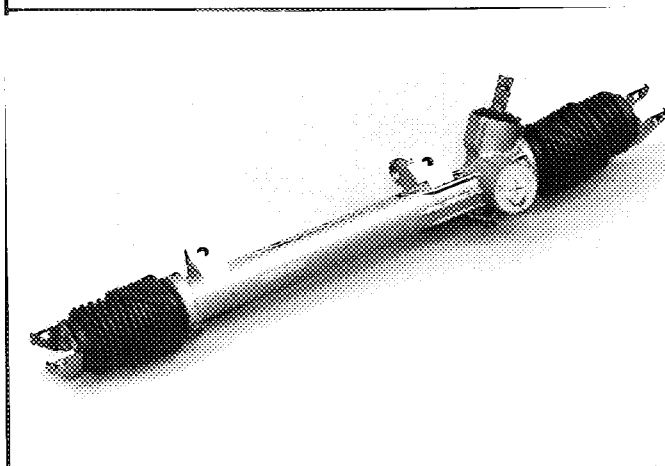

Marke BMW
Make

Modell M3
Model

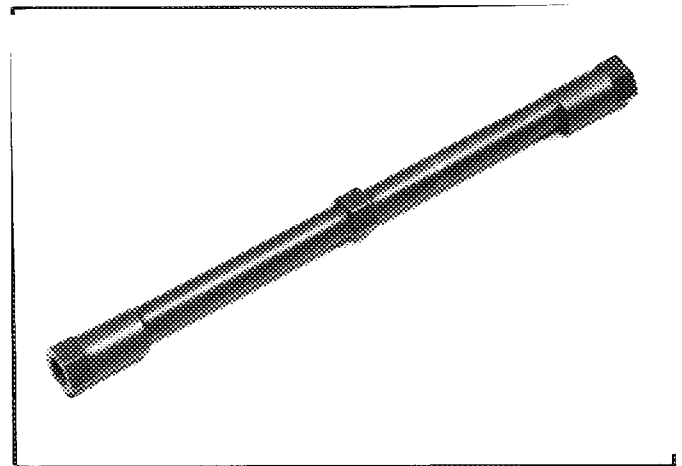
Homologations Nr. A 5327
Homologation Nr.

Fotos
Photos

Nachtrag Nr. 38 / 20 V0
Ext. Nr.



Foto 7



FÉDÉRATION INTERNATIONALE DU SPORT AUTOMOBILE

ONS Oberste Nationale Sportkommission für den Automobilsport in Deutschland GmbH

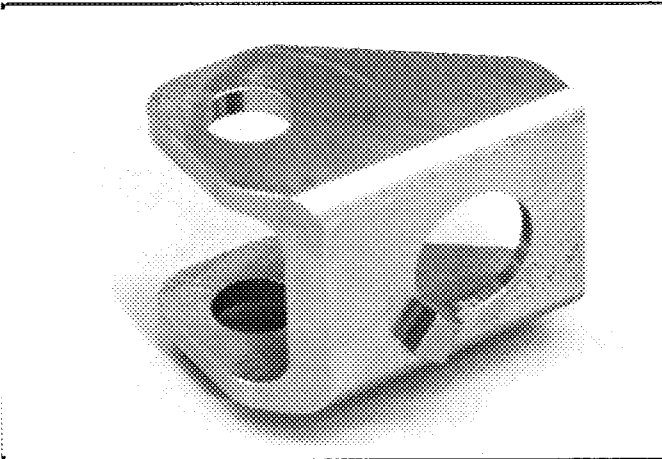
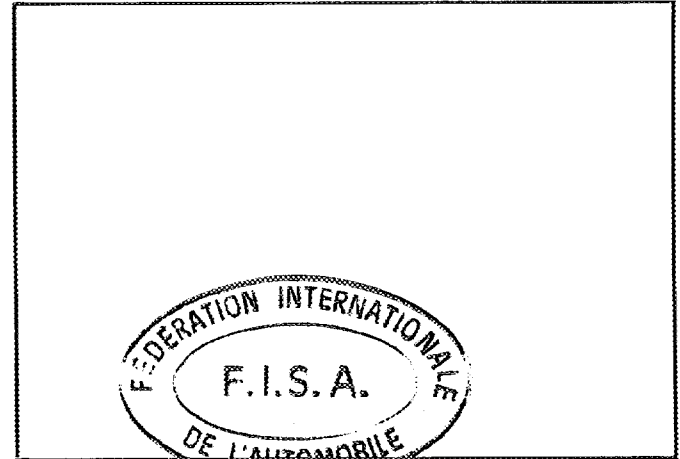
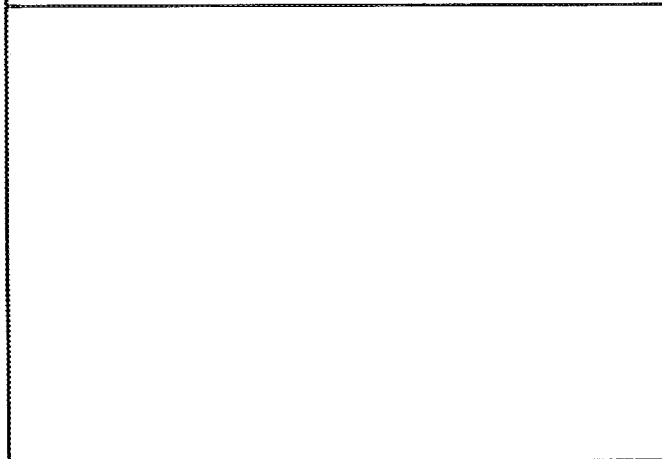
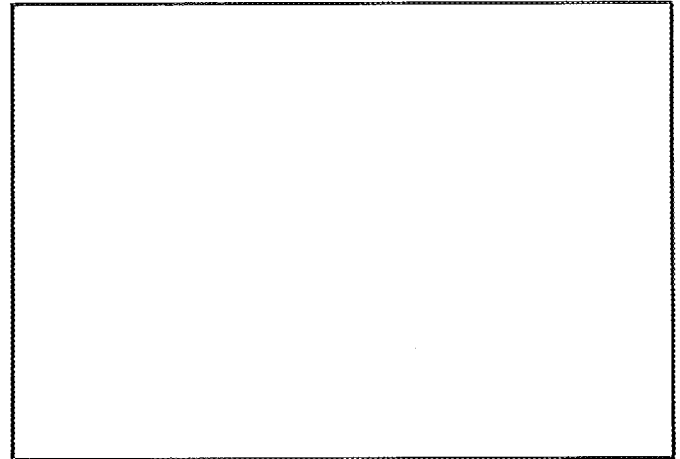
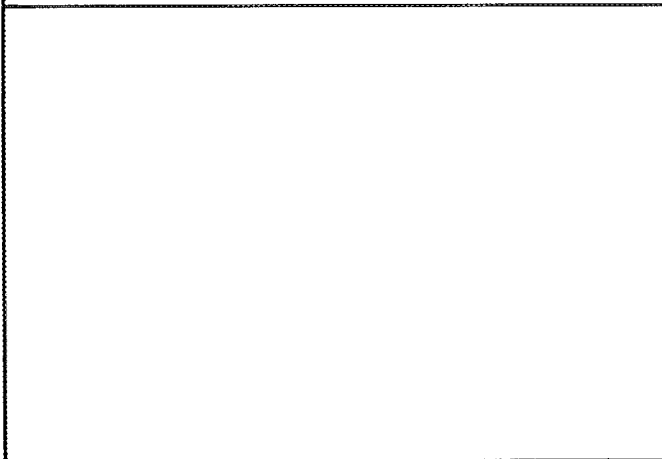
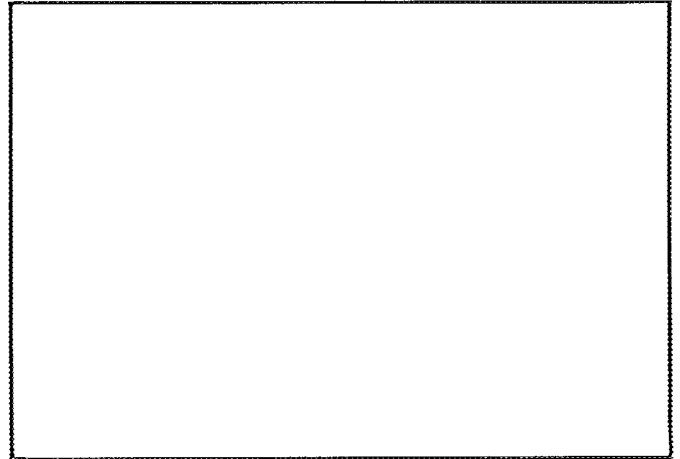
Homologation Nr.

A - 5327

Nachtrag Nr.
Extension Nr.

39 / 2 1 VO

Nachtrag zum offiziellen Testblatt der FISA

Form of extension to the official FISA-Homologation

- ET** Normale Weiterentwicklung des Typs: ab Fahrgestell-Nr.: _____
Normal evolution of the type, as from chassis number.
- ES** Sportevolution
Sporting evolution
- VF** Liefervariante
Supply variant
- VO** Ausstattungsvariante
Option variant
- ER** Berichtigung
Erratum

Homologation gültig ab: 01.04.92 in Gruppe: A
Homologation valid as from: _____ in group: _____

Hersteller: BMW Motorsport GmbH Modell und Typ: BMW M3
Manufacturer: _____ Model and type: _____

Seite od. Nachtrag Page or ext.	Artikel Art.	Beschreibung Description	
33/16 VO	803G7	Photo, zusätzlich 263 +/- 1,5 mm additional	Foto 1
Seite 8	803 G	Bremsscheibentopf / Brake disc mounting bell	Foto 2
	803	Halter für Bremssattel, vorne / Bracket for brake caliper, front	Foto 3
36/18 VO	803G7	Photo, zusätzlich/additional 198 +/- 1,5 mm	Foto 4
Seite 7	701A	Verstärktes Federbein/reinforced wheel upright	Foto 5
	701B	Verstärkter Querlenker/reinforced rear suspension	Foto 6
38/20 VO Photo 1		Verstärktes Getriebegehäuse/reinforced gear box housing	Foto 7
Seite 9	901F2	Geänderte Position/changed position (Bedingt durch Sicherheitskäfig/ caused by roll cage)	Foto 8

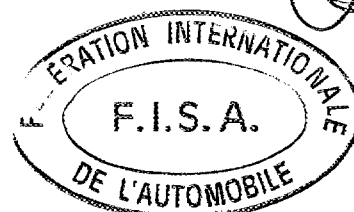

Marke BMW
Make

Modell M3
Model

Homologations Nr. A 5327
Homologation Nr.

39 / 2 1 V0

Fotos
Photos

Nachtrag Nr. _____
Ext. Nr.



Foto 1



Foto 2

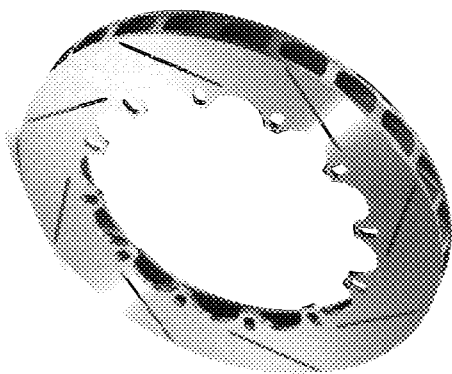

Foto 3

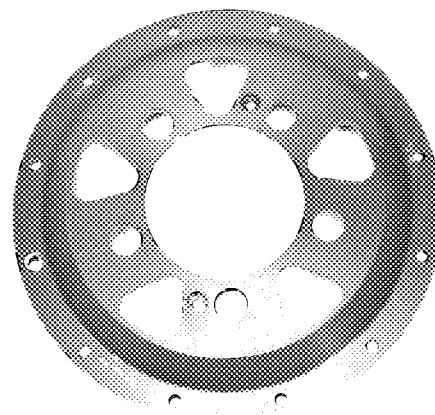

Foto 4

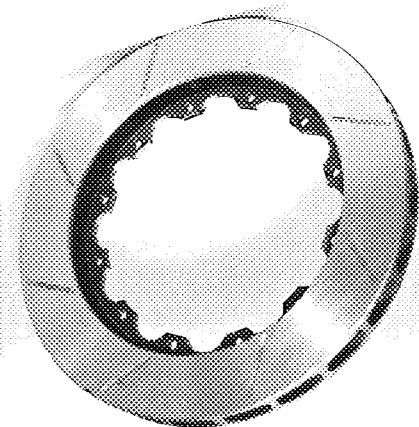

Foto 5

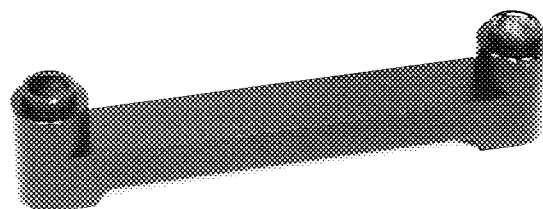

Foto 6

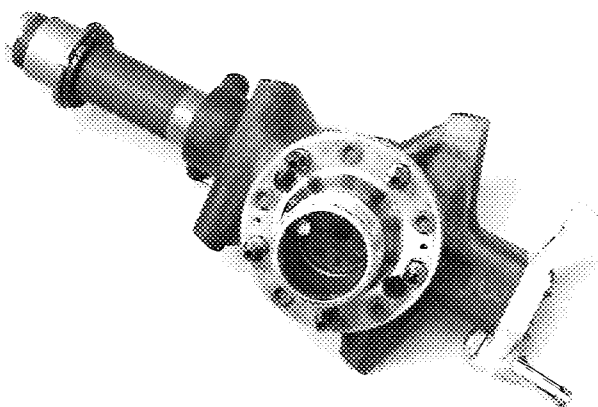

Marke BMW
Make

Modell M3
Model

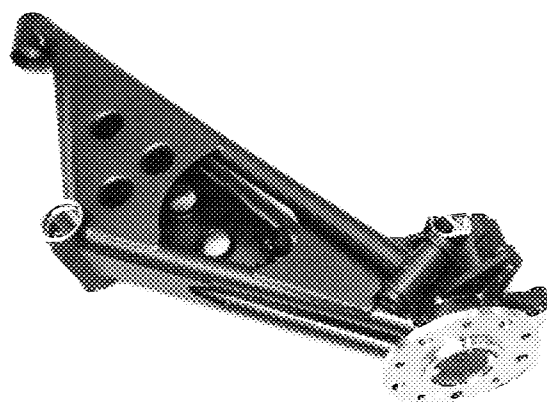
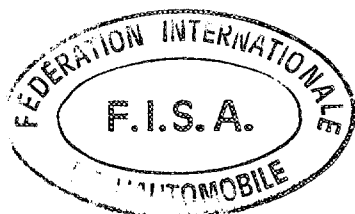
Homologations Nr. A 5327
Homologation Nr.

39 / 2 1 V0

Fotos
Photos

Nachtrag Nr. _____
Ext. Nr.



Foto 7

Foto 8

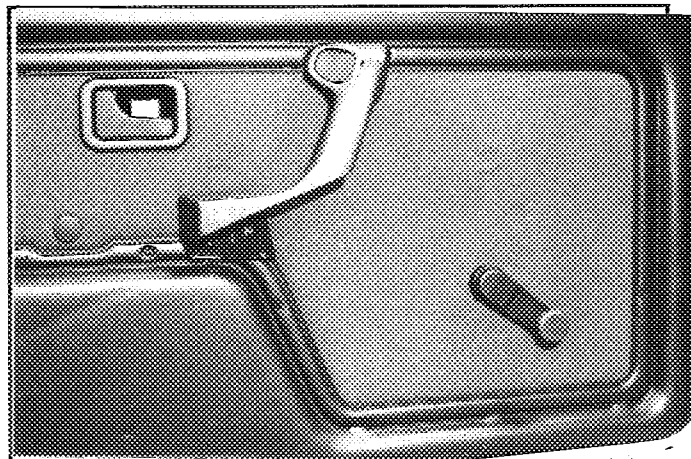
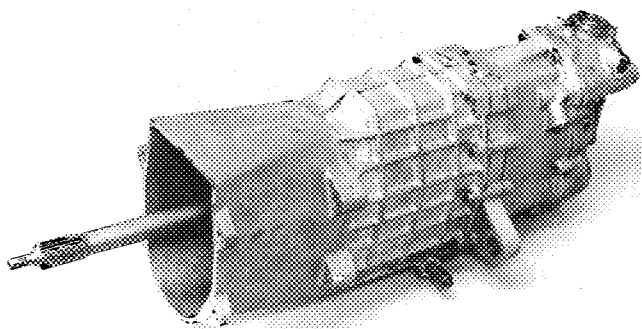
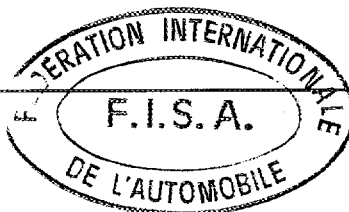

FÉDÉRATION INTERNATIONALE DU SPORT AUTOMOBILE

ONS Oberste Nationale Sportkommission für den Automobilsport in Deutschland GmbH

Homologation Nr.

A 5327

Nachtrag Nr.
Extension Nr.

40 / 22 VO

Nachtrag zum offiziellen Testblatt der FISA

Form of extension to the official FISA-Homologation

- ET** Normale Weiterentwicklung des Typs: ab Fahrgesteil-Nr.: _____
Normal evolution of the type: as from chassis number.
- ES** Sportevolution
Sporting evolution
- VF** Liefervariante
Supply variant
- VO** Ausstattungsvariante
Option variant
- ER** Berichtigung
Erratum

Homologation gültig ab: 01. Juli 1992 in Gruppe: A
Homologation valid as from: _____ in group: _____

Hersteller: BMW Motorsport GmbH Modell und Typ: BMW M3
Manufacturer: _____ Model and type: _____

Seite od. Nachtrag Page or ext.	Artikel Art.	Beschreibung Description	
Seite 7	605	Verstärktes Hinterachsgehäuse / reinforced rear axle housing	Foto 1
	605	Regelsystem / control system (in the cockpit)	Foto 2
	701A	Verstärktes Federbein / reinforced wheel upright	Foto 3
	701B	Verstärkte Hinterradaufhängung / reinforced rear suspension	Foto 4
		Verstärkte Hinterradaufhängung / reinforced rear suspension	Foto 5
Seite 8	803A	Hydraulikeinheit mit Steuergerät / hydraulic unit with control unit (in the cockpit)	Foto 6
	803D	Bremskraftregler im Fahrgastraum / braking adjuster in passenger compartment	Foto 7
Nachtrag / extension 30/15 VO Foto 12		Bremssättel passend zu allen Bremsscheiben mit Außendurchmesser 332,0 +/- 1,5 mm / brake calipers for all brake discs with outside diameter 332,0 +/- 1,5 mm	Foto 8

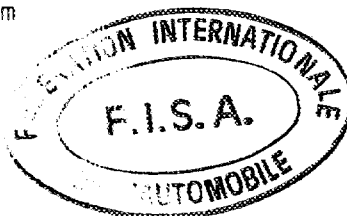

Marke BMW
Make

Modell M3
Model

Homologations Nr. A 5327
Homologation Nr.

Nachtrag Nr. 40 / 22 V0
Ext. Nr.

Seite od. Nachtrag Page or ext	Artikel Art	Beschreibung Description	
Nachtrag / extension 39/21 V0 Foto 2		Bremsscheibentopf / brake disc mounting bell	Foto 10
Nachtrag / extension 33/16 V0 Foto 9 + 10 Foto 15	803	Bremsscheiben vorn / brake discs, front	
	803G5	zusätzlich / additional 367 mm +/- 1,5 mm	
	803G6	zusätzlich / additional 366 mm +/- 1,5 mm	
	803G7	zusätzlich / additional 274 mm +/- 1,5 mm	

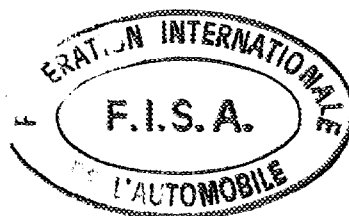

Marke BMW
Make

Modell M3
Model

Homologations Nr. A 5327
Homologation Nr.

Fotos
Photos

Nachtrag Nr. 40 / 22 V0
Ext. Nr.



Foto 1



Foto 2

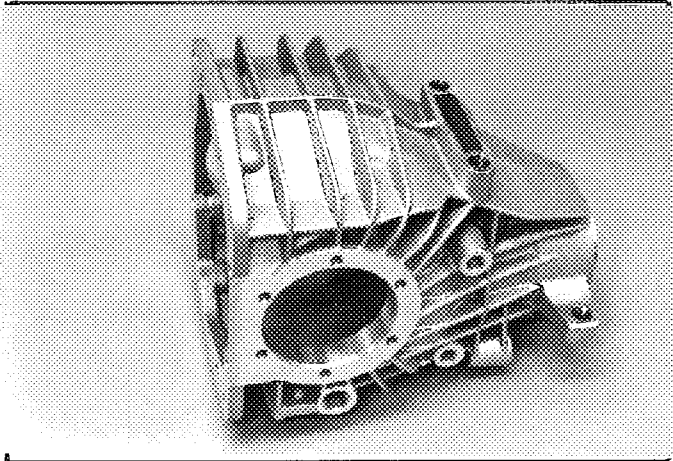

Foto 3

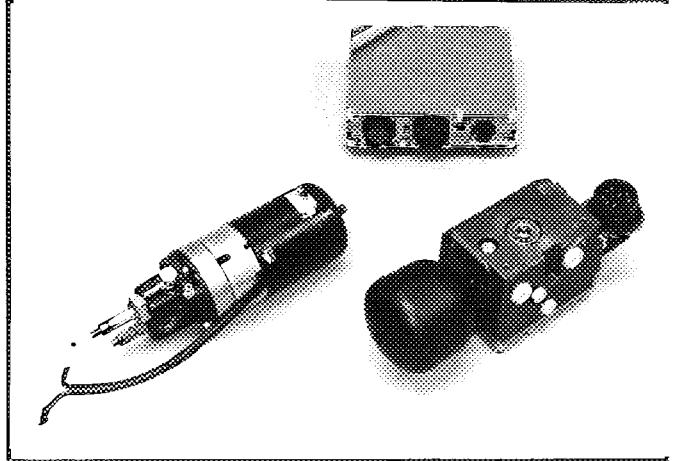

Foto 4

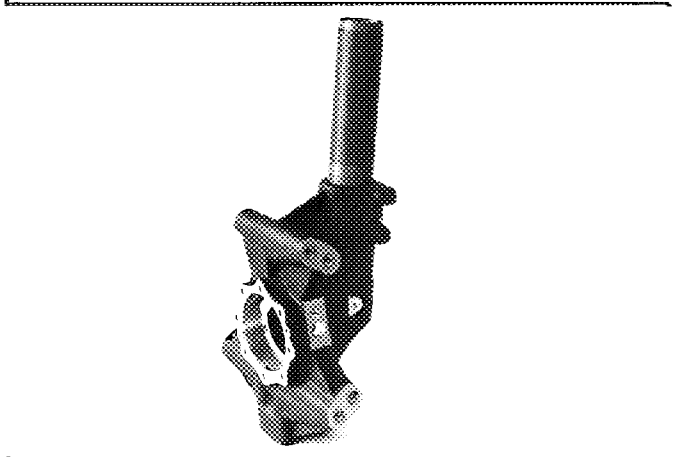

Foto 5

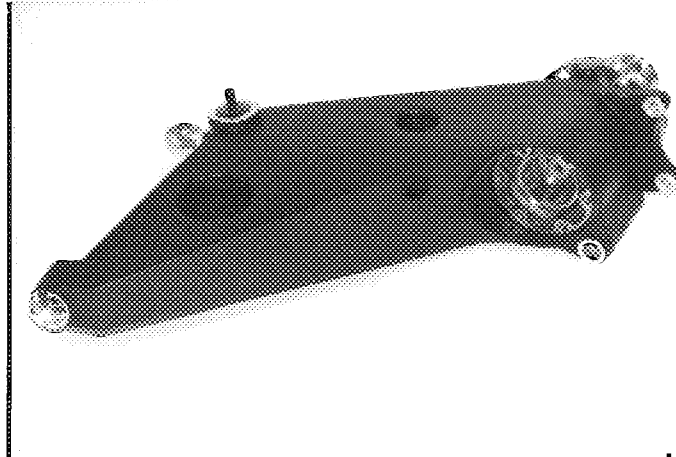

Foto 6

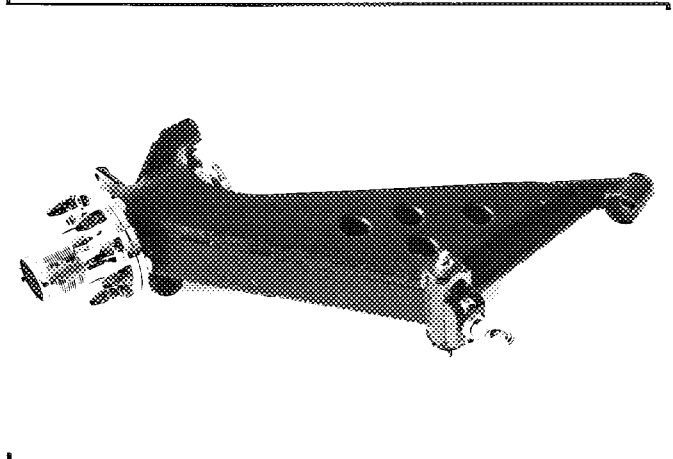

Marke BMW
Make

Modell M3
Model

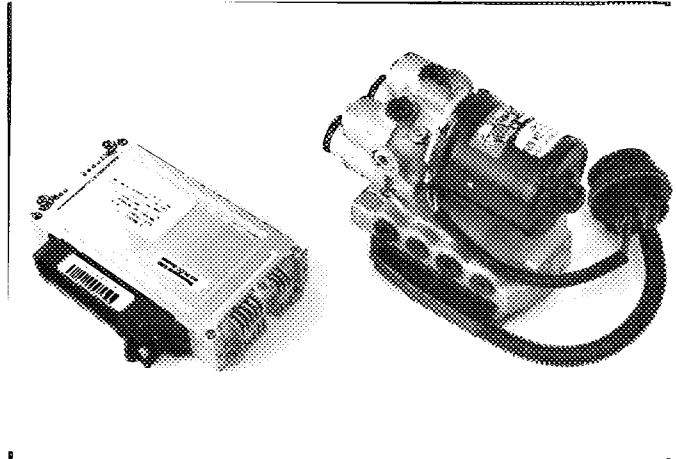
Homologations Nr. A 5327
Homologation Nr.

40 / 22 V0

Fotos
Photos

Nachtrag Nr. _____
Ext. Nr.



Foto 7



Foto 8

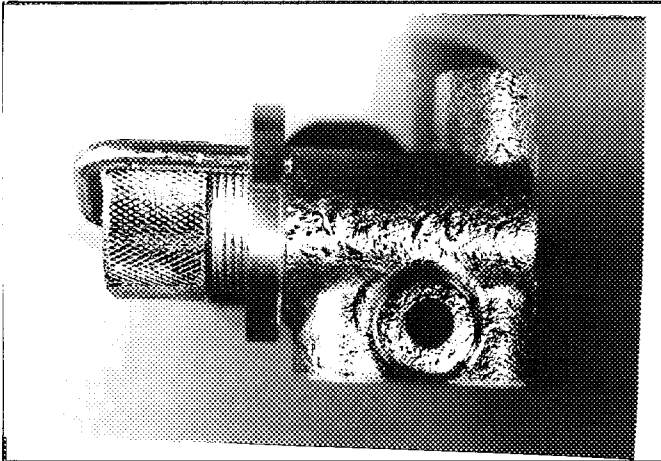

Foto 10

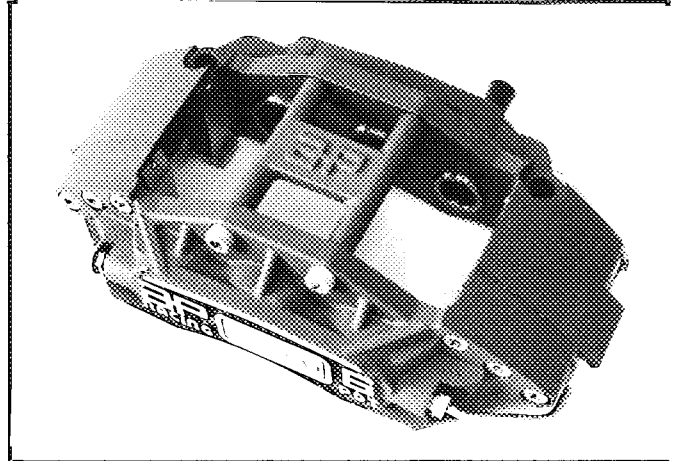

FÉDÉRATION INTERNATIONALE DU SPORT AUTOMOBILE

ONS Oberste Nationale Sportkommission für den Automobilsport in Deutschland GmbH

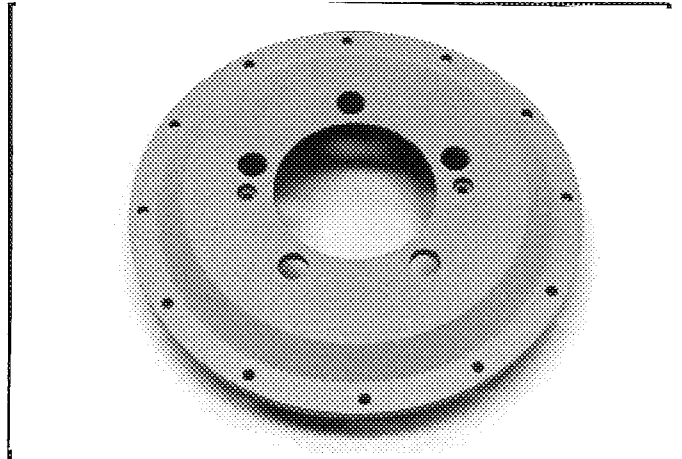
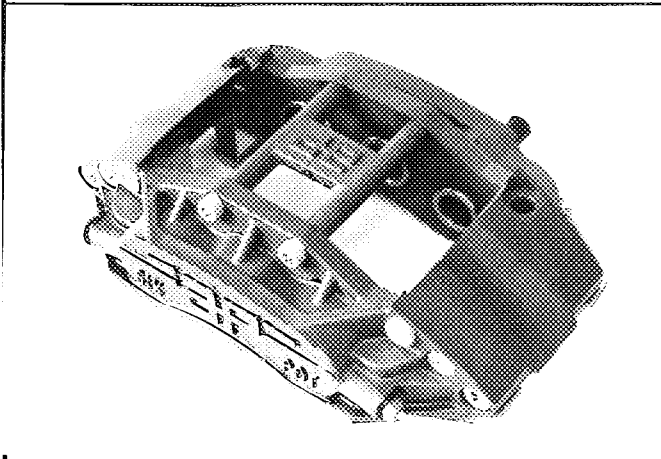
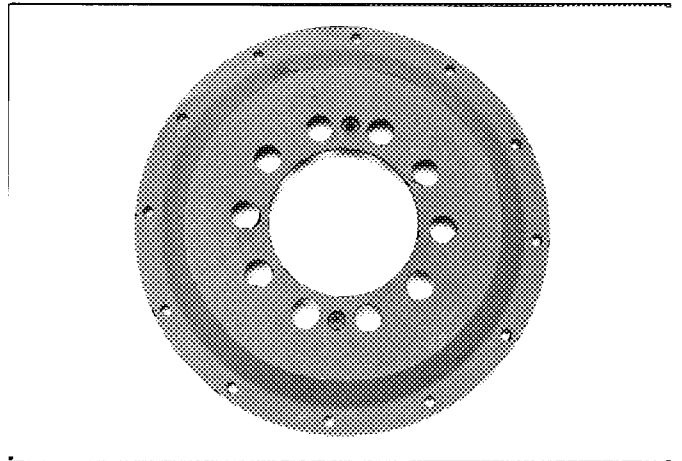
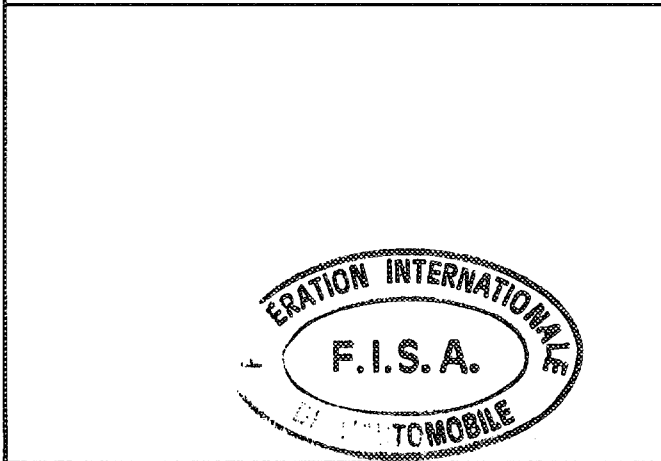
Homologation Nr.

A 5327

Nachtrag Nr.
Extension Nr.

41 / 23 VO

Nachtrag zum offiziellen Testblatt der FISA

Form of extension to the official FISA-Homologation

- ET** Normale Weiterentwicklung des Typs: ab Fahrgestell-Nr.: _____
Normal evolution of the type as from chassis number:
- ES** Sportevolution
Sporting evolution
- VF** Liefervariante
Supply variant
- VO** Ausstattungsvariante
Option variant
- ER** Berichtigung
Erratum

Homologation gültig ab: 01.07.1992 in Gruppe: A
Homologation valid as from: _____ in group: _____

Hersteller: BMW Motorsport GmbH Modell und Typ: BMW M3
Manufacturer: _____ Model and type: _____

Seite od. Nachtrag Page or ext.	Artikel Art.	Beschreibung Description	
Seite 7	701 A	Federbeinstützlager, verstärkt / top mounting plate, reinforced	Foto 1
Seite 8	803	Bremsscheibenbelüftung, vorne / front brake disc ventilation	Foto 2
	803 A	Hydraulikeinheit für ABS / hydraulic unit for ABS (in the engine compartment)	Foto 3



Marke BMW
Make

Modell M3
Model

Homologations Nr. A 5327
Homologation Nr.

41 / 23 V0

Fotos
Photos

Nachtrag Nr. _____
Ext. Nr.



Foto 1



Foto 2

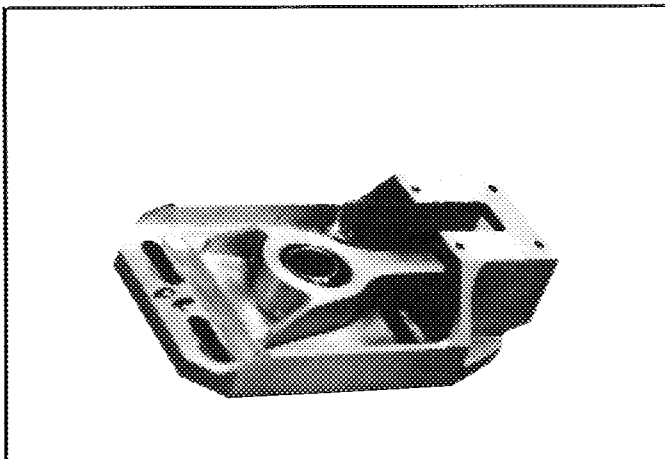

Foto 3

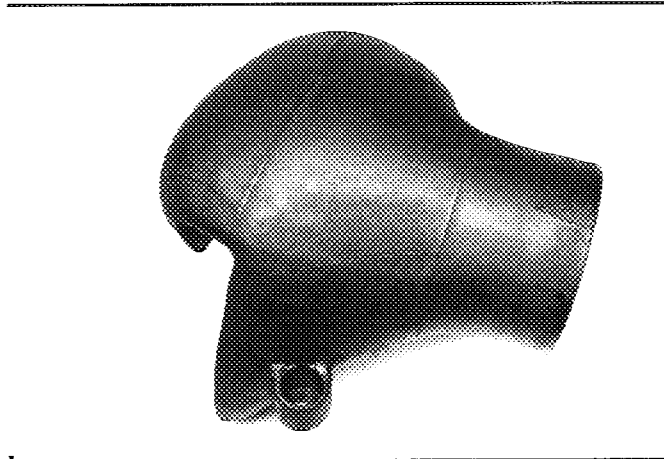

FÉDÉRATION INTERNATIONALE DU SPORT AUTOMOBILE
ONS Oberste Nationale Sportkommission für den Automobilsport in Deutschland GmbH

Homologation Nr.

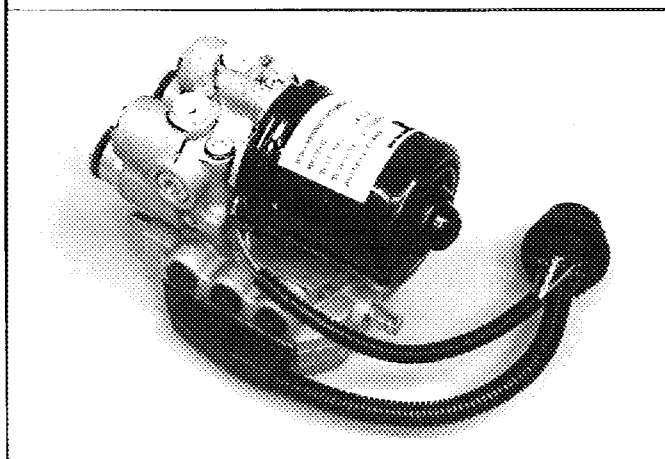
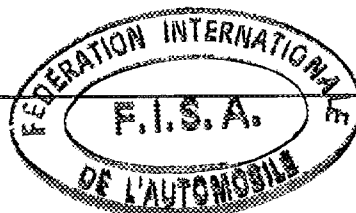
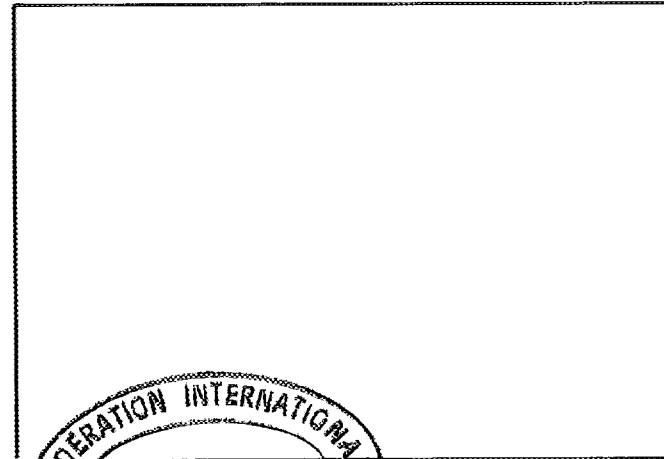
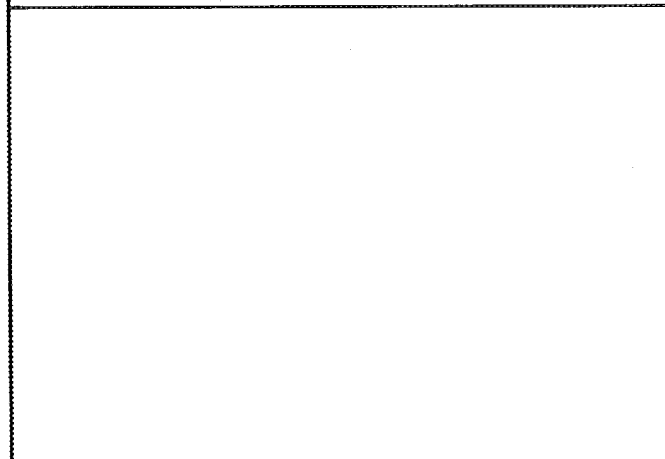
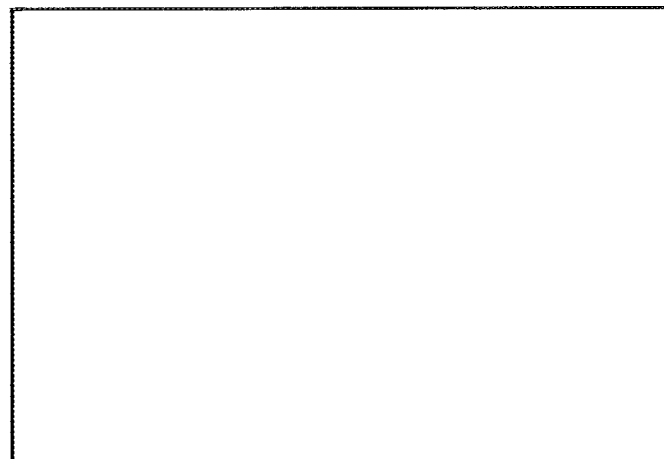
A - 5327

Nachtrag Nr.
Extension Nr.

42 / 11 ER

Nachtrag zum offiziellen Testblatt der FISA

Form of extension to the official FISA-Homologation.

- ET** Normale Weiterentwicklung des Typs: ab Fahrgestell-Nr.: _____
Normal evolution of the type, as from chassis number:
- ES** Sportevolution
Sporting evolution
- VF** Liefervariante
Supply variant
- VO** Ausstattungsvariante
Option variant
- ER** Berichtigung
Erratum

Homologation gültig ab: 01 JAN. 1993 in Gruppe: A
Homologation valid as from, in group

Hersteller: BMW Motorsport GmbH Modell und Typ: BMW M3
Manufacturer Model and type

Seite od. Nachtrag Page or ext.	Artikel Art.	Beschreibung Description
Seite 1	101	Bisheriger Herstellername: BMW Motorsport GmbH Neuer Herstellername: BMW AG Previous manufacturer name: BMW Motorsport GmbH New manufacturer name: BMW AG

